



35 / EN

HL Hutterer & Lechner GmbH

www.hl.at



SIPHONS ABLÄUFE

CATALOGUE 35/EN

1. Kitchen	7	12. Balcony and terrace	143
Basic information about design and installation	8	Basic information about design and installation	144
Products	9	Selection of the convenient drain	145
2. Washbasin	19	Installation examples	146
Basic information about design and installation	20	Installation	147
Product overview	20	Product overview	148
Products	21	Products	150
3. Bath tubs	27	Attika drains	160
Basic information about design and installation	28	Basic information about design and installation	160
Product overview	28	Installation examples	160
Products	29	Products	163
4. Shower trays	33	13. Floor	167
Basic information about design and installation	34	Basic information about design and installation	168
Product overview	35	Selection of the convenient drain	169
Installation	36	Installation examples	170
Products	38	Installation	171
5. Barrier-free showers	43	Product overview	172
Basic information about design and installation	45	Products	176
Installation examples	46	14. Sealing kits / Extensions	201
Installation	48	Sealing kits - product overview	202
Products	52	Extensions - product overview	204
6. Washing devices	71	Sealing kits - products	206
Basic information about design and installation	72	Extensions - products	211
Product overview	72	15. Major drains of "perfect series"	215
Installation	74	Basic information about design and installation	216
Products	75	Selection of the convenient drain	217
7. Air condition and ventilation	83	Installation examples	218
Basic information about design and installation	84	Installation	219
Products	85	Product overview	220
8. Toilet	89	Products	222
Basic information about design and installation	90	16. Anti-flooding valves	231
Products	90	Basic information about design and installation	232
9. Urinals	95	Image of a drainage system	232
Basic information about design and installation	96	Selection of the convenient valve	233
Products	96	Product overview	234
10. Air admittance valves	99	Products	236
Basic information about design and installation	100	17. Rain hoppers	243
Calculation of air flow - function	101	Basic information about design and installation	244
Products	102	Installation, maintenance, cleaning	247
11. Roof	107	Products	248
Basic information about design and installation	108	18. Pipe sleeves	251
Selection of the convenient drain	109	Basic information about design and installation	252
Installation examples	110	Product overview	253
Installation	112	Installation	254
Product overview	114	Products	255
Products	116	Quick search for HL801 V/R/B	258
Safety drainage	131	19. Accessories	259
Basic information about design and installation	132	Fire protection - function and installation	260
Calculation examples – function	133	Products	261
Product overview	136	Sound insulation	266
Products	137	Note	269

Index

Article	Page	Article	Page	Article	Page	Article	Page	Article	Page	Article	Page
HL050D	59	HL11	12	HL42.MS	264	HL64HSafe	139	HL80	150	HL134	1)*
HL050I	59	HL12.1(2)(3)(4)	12	HL43	264	HL64P	122	HL80CR	1)*	HL134.0	22
HL050S	59	HL12.5	24	HL44	1)*	HL64PPower	124	HL80H	150	HL134.1C	22
HL050.3EN	59	HL13	12	HL45	265	HL64PPowersafe	141	HL80HR	1)*	HL134.1K	22
HL053M.2	65	HL13.0/40	1)*	HL50F.0	52	HL64PSafe	140	HL80R	1)*	HL134.2	1)*
HL053P.2	65	HL13-2/40	13	HL50FF.0	53	HL64Safe	139	HL80.1	176	HL135	22
HL053M	64	HL13G	13	HL50FU.0	54	HL64.1	120	HL80.1H	176	HL136T	86
HL053P	64	HL13G.0/40	1)*	HL50FV.0	58	HL64.1B	121	HL80.1HR	1)*	HL136.2	85
HL053S	64	HL14/90	13	HL50W.0	55	HL64.1BF	123	HL80.1R	177	HL136T.3	86
HL053WS	65	HL15	14	HL50WF.0	56	HL64.1BH	121	HL80.2	177	HL137N	23
HL062.1Safe	141	HL15.1	25	HL50WU.0	57	HL64.1BP	123	HL80.2H	1)*	HL137N.1	24
HL066C.1E	68, 188	HL15U	14	HL51	30	HL64.1F	122	HL80.3	126	HL137N-BV	23
HL066Q.1E	68, 188	HL15U-90	14	HL53.0	62	HL64.1FSafe	140	HL80.3H	126	HL137N-WM	24
HL068.1E	165	HL16	31	HL53PrBlue.0	62	HL64.1H	120	HL81G	151	HL138N	87
HL068.1Safe	165	HL16.1	42	HL53FPPrBlue.0	62	HL64.1HSafe	139	HL81.1G	1)*	HL138NH	87
HL080.8E	158	HL17	81	HL53Duo.0	63	HL64.1P	122	HL81GH	151	HL150	158
HL0317.4E	106	HL18	81	HL53V.0	63	HL64.1PSafe	140	HL81.1GH	1)*	HL151	158
HL0530.G/	1)*	HL19(0)(2)(.C)	82	HL54F	1)*	HL64.1Safe	139	HL82	159	HL152	158
B/C/S/W	1)*	HL19T(.2)	25	HL54W	1)*	HL65	127, 212	HL83	208	HL153	158
HL0530.GG/ BG/	1)*	HL20	85	HL54I	1)*	HL65F	127, 213	HL83.H	209	HL154	1)*
SG/WG	1)*	HL21	85	HL62	116	HL65H	127, 213	HL83.M	207	HL155	159
HL0531Prblue D	67	HL22	14	HL62B	117	HL65P	127, 213	HL83.P	210	HL156	159
HL0531Prblue I	67	HL23	15	HL62BF	119	HL65PE	127, 213	HL83.PP	210	HL157	158
HL0531Prblue S	67	HL24	15	HL62BH	117	HL66(Q)	197	HL83.0	206	HL160	129
HL0540I	68, 188	HL24U	15	HL62BP	119	HL66P	1)*	HL84	208	HL161	129
HL0541I	69, 189	HL25U	16	HL62F	118	HL66.1	197	HL84.0	206	HL163	165
HL0542.1E	70	HL26	16	HL62FSafe	137	HL66.3(.4)	198	HL84.CU	210	HL163.1	166
HL0542.7E	70	HL27	16	HL62H	116	HL66.8(.9)	1)*	HL84.E	210	HL163Safe	166
HL0635N.2	128	HL28	17	HL62HSafe	137	HL67	1)*	HL84.H	209	HL164	166
HL0635N.3	128	HL30	264	HL62P	118	HL68H.0	163	HL84.L	210	HL170	1)*
HL0710E.X	237	HL34	25	HL62PSafe	138	HL68F.0	163	HL84.M	207	HL175	129
HL0715E.X	237	HL35	1)*	HL62Safe	137	HL69	125	HL85N	212	HL180	159
HL03910.3E	198	HL35.0	1)*	HL62.1	116	HL69H	125	HL85NH	213	HL181	159
HL2	80	HL36N	1)*	HL62.1Safe	137	HL69P	126	HL86	208	HL190	229
HL2.0	80	HL37(F)Prblue	193	HL62.1B	117	HL70	239	HL86.0	206	HL191	229
HL2.1	81	HL37N	193	HL62.1BF	119	HL70G	239	HL86.H	209	HL195	229
HL2.2	81	HL37NP	194	HL62.1BH	117	HL71	239	HL86.M	207	HL200	90
HL3	11	HL37NP	193	HL62.1F	118	HL71G	239	HL90	151	HL201	90
HL4	242	HL37Prblue	193	HL62.1FSafe	138	HL71.1	240	HL90.2	152	HL202	91
HL4/7	242	HL37PPrblue	195	HL62.1H	116	HL72	240	HL90KH	152	HL202G	91
HL5	263	HL37N.1	193	HL62.1HSafe	137	HL72N	240	HL90Prblue	186	HL203	91
HL6	11	HL37NP.1	195	HL62.1BP	119	HL72.1	192	HL90Prblue-D	187	HL203/90	91
HL7EL	94	HL38N	195	HL62.1P	118	HL72.1H	192	HL90Prblue-3000	186	HL204	91
HL7.WE	94	HL38N.1	195	HL62.1PSafe	138	HL72.1HN	192	HL90Prblue-D-3000	187	HL205	92
HL8EL	11	HL38Prblue	195	HL64	120	HL72.1N	192	HL90Prblue-3020	187	HL209	92
HL9	262	HL38P	195	HL64B	121	HL73(Pr).(0).(2)	241	HL92	1)*	HL210	92
HL9ET	262	HL39	1)*	HL64BF	123	HL77	241	HL98	263	HL210P	92
HL10	11	HL39Prblue	1)*	HL64BH	121	HL77.1	242	HL98SML	263	HL210.7	92
		HL39.1	1)*	HL64BP	123			HL100	9	HL222	93
		HL39G	196	HL64F	122			HL100G	9	HL224	93
		HL39.1G	1)*	HL64FPower	124			HL126	10	HL224.1	93
		HL39PrblueG	1)*	HL64FPowersafe	141			HL126.2	10	HL225/90	93
		HL40	264	HL64FSafe	140			HL130	96	HL225.1/90	94
		HL41	264	HL64H	120			HL132	21	HL226	1)*
		HL42	264	HL64HPower	124			HL132.1	21	HL227	1)*
				HL64HPowersafe	141			HL133	21	HL300	178

1)* Article see www.hl.at

Index

Article	Page	Article	Page	Article	Page	Article	Page	Article	Page	Article	Page
HL300G	1)*	HL500	31		68,	HL615L	224	HL715.2EPC	238		69,
HL300R	1)*	HL500N	31	HL540-Cut	188	HL615LW	224	HL720	236	HL3123	189,
HL303K	178	HL510N	184		68,	HL615S	224	HL720.0	236		199
HL304	179	HL510N-3000	184	HL540-Hamam	188	HL615SW	224	HL720.1	236		69,
HL306	1)*	HL510N-3020	184		69,	HL615W	224	HL720.2	237	HL3124	189,
HL307	1)*	HL510Prblue-3020	184	HL541(I)	189	HL615.1	224	HL800	255		199
HL307.0	1)*	HL510N-3120	1)*		70,	HL615.1H	225	HL800.2	255		69,
HL308	1)*	HL510N-3121	1)*	HL542Prblue	190	HL615.1HW	225	HL801	256		189,
HL310N	179	HL510N-3123	1)*		70,	HL615.1W	224	HL801B	257	HL3125	199
HL310N-3000	179	HL510N-3124	1)*	HL542Prblue.0	190	HL616	226	HL801R	257		69,
HL310N-3020	180	HL510N-3125	1)*		190	HL616H	227	HL801V	257		199
HL310N-3120	1)*	HL510NG	185	HL555N	29	HL616HL	227	HL804H	256		69,
HL310N-3121	1)*	HL510KH	1)*	HL555N.0	29	HL616HLW	227	HL805	265	HL3127	189,
HL310N-3123	1)*	HL510Prblue	185	HL555N.1	29	HL616HS	227	HL807	265		199
HL310N-3124	1)*	HL510Prblue-3000	185	HL555N.2	29	HL616HSW	227	HL810	265		68,
HL310N-3125	1)*	HL510Prblue-3120	1)*	HL555N.3	29	HL616HW	227	HL840	261	HL3128E	188
HL310NG	180	HL510Prblue-3121	1)*	HL555N.4	29	HL616L	226	HL870	261		1)*
HL310KH	153	HL510Prblue-3123	1)*	HL555N.L.0	29	HL616LW	226	HL900N	102	HL3210	211
HL310Prblue	181	HL510Prblue-3124	1)*	HL560N	30	HL616S	226	HL900NECO	102	HL3400	196
HL310Prblue-3000	181	HL510Prblue-3125	1)*	HL560N.L	30	HL616SW	226	HL901	102	HL3910	196
HL310Prblue-3020	180	HL510PrblueG	186	HL570	38	HL616W	226	HL902	106	HL3910.1	197
HL310Prblue-3120	1)*	HL510PrblueR	186	HL570.0	38	HL616.1	226	HL902T	103	HL3910G(V)	196
HL310Prblue-3121	1)*	HL510NR	185	HL570.0-Plan	38	HL616.1H	227	HL903	103	HL3910Pr	196
HL310Prblue-3123	1)*	HL511N	40	HL600N	248	HL616.1HW	227	HL904	102	HL3911	196
HL310Prblue-3124	1)*	HL513/S	41	HL600NG	248	HL616.1W	226	HL904T	103		68,
HL310Prblue-3125	1)*	HL513/S(.0)	41	HL600NHO	249	HL618	212	HL905N(.0)	104	HL3928	188,
HL310PrblueG	181	HL513-100G/50	1)*	HL600NGHO	249	HL618H	213	HL905.1(.2)(.3)(.4)	105		197
HL310PrblueR	181	HL514	41	HL601i	248	HL619	159,	HL905.1V (2V)	105	HL4000.0	23,
HL310NR	180	HL514/S.1	40	HL603	129		230	HL990	106		76
HL310N.2	153	HL514/S.2	40	HL605	222	HL620	211	HL3000	193	HL4000.1	76
HL317	183	HL514/S.3	40	HL605L	222	HL621	228	HL3000.1	194	HL4000.2	76
HL317H	183	HL514/S.11	40	HL605LW	222	HL622	228	HL3011	193	HL4000.3	23
HL317KHN	1)*	HL514/SN	40	HL605S	222	HL622/S	228	HL3000(F)Prblue	194	HL5100	191
HL317KN	1)*	HL514/SN.0	40	HL605SW	222	HL623	228	HL3020	194	HL5100T	154
HL320	211	HL515	42	HL605W	222	HL624	229	HL3100	182	HL5100TG	155
HL340N	211	HL515/S	42	HL605.1	222	HL624V	229	HL3100Pr	182	HL5100TH	154
HL350	211	HL517	42	HL605.1W	222	HL635N	128	HL3100T	156	HL5100THG	155
HL350.1(.0)	212	HL520	1)*	HL606	223	HL635N.0(.2)(.3)	128	HL3100TG	157	HL5100Pr	191
HL350.1H	213	HL520F	39	HL606L	223	HL636N	128	HL3100TH	156	HL6100	266
HL350.2	1)*	HL521	39	HL606LW	223	HL703	94	HL3100THG	157	HL6200	266
HL400	75	HL522.1(2)(3)(11)	39	HL606S	223	HL710	236	HL3110	198	HL6300	266
HL404	75	HL522V	1)*	HL606SW	223	HL710.0	236		69,	HL6600	266
HL404.1	75	HL522V.0	1)*	HL606W	223	HL710.1	236	HL3120	189,	HL6600.2	267
HL405	77	HL523N	1)*	HL606.1	223	HL710.2	237		199	HL6700	266
HL405B	82	HL524	1)*	HL606.1W	223	HL710.1V	238		69,	HL6800	267
HL405E	77	HL525	42	HL608(1)	1)*	HL710.2EPC	238	HL3121	189,	HL8300	208
HL405ECO	78	HL526	42	HL609	230	HL712	236		199	HL8300.0	206
HL406	78	HL531Prblue	66	HL610	1)*	HL712.0	236		69,	HL8300.H	209
HL406.2	79	HL531U	1)*	HL615	224	HL712.1	236	HL3122	189,	HL8300.M	207
HL406E	79	HL531V	66	HL615H	225	HL712.2	237		199	HL8300.P	210
HL410	80		68,	HL615HL	225	HL712.2EPC	238		199	HL8300.PP	210
HL420	82	HL540(I)	188	HL615HLW	225	HL715	236		69,	HL8500	212
HL421	82		68,	HL615HS	225	HL715.0	236		199	HL8500H	213
HL430	97	HL540-Quadra	188	HL615HSW	225	HL715.1	236				
HL431	97			HL615HW	225	HL715.2	237				
HL440	80										



SIPHONS ABLÄUFE

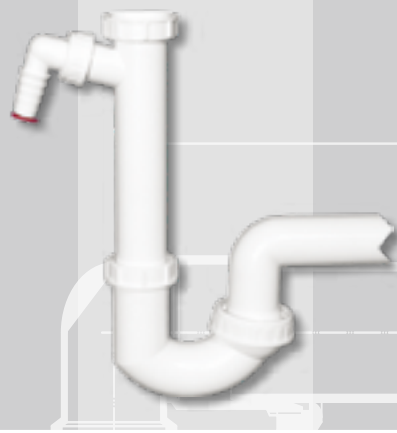

120-325

R6/4"



42



DN40 = 95-270
DN50 = 100-280

HL Siphons

1. Kitchen

1



HL Kitchen siphons

Basic information about design and installation

HL supplies a lot of different possibilities of connecting and siphoning kitchen sinks and washing devices (dishwashers). Here are answers to the most frequently ask questions.

▲ **Prevention from pluggings:**

When connecting the kitchen sink, you should always take care, to use minimum DN40 pipes and siphons, to avoid a plugging (by e.g. cooking fat).

▲ **Sound minimisation:**

When wastewater from e.g. dishwashers flows into the siphon, a high sound level occurs, when the sewage impinges on the water seal. Therefore we recommend, to use kitchen traps with double wall immersion tubes, like e.g. HL100, HL126 and HL126.2

▲ **Prevention from backwater to the washing device:**

When the sewer is plugged, there is a big risk, that the sewer flows back to the dishwasher. Therefore we recommend the usage of washing device connectors with integrated backflow flaps (all types of HL are provided

with adequate membranes). To upgrade existing connectors without backflow flaps we recommend the usage of HL3.

▲ **Prevention from leakage:**

Leakage water is one of the most common reasons for reclamations in fitted kitchens, as it is recognized very late and therefore expensive. To prevent from claims, the plumber should take care of save and tight connections to the sink. HL provides it's siphons with plastic gaskets and cap nuts, which are on the one hand waterproof and on the other hand save only by turning by hand.

▲ **Flexibility:**

As the connection to the sewage pipe mostly is in the wall and therefore in an inconvenient position, it is important to reach the pipe inlet by turning or bowing. HL enables the plumber to connect the siphon to the wallside inlet of the pipe without tension.

▲ **Overflow:**

When buying a kitchen sink, please take care, that it is supplied together with a fitting overflow kit. HL supplies standard overflow kits, which in fact do not fit to all sinks.

▲ **Space saving:**

To use the whole space under the kitchen sink for storage, it is useful, to install siphons, which are located directly to the wall. Our types HL126 and HL126.2 are equipped with adequate connectors (HL26), so that an installation close to the wall is possible.

Relevant standards/directives

EN 274 Drains and siphons for sanitary equipment

HL Kitchen siphons – Products – Data

HL100 Tubular trap with backwater membrane connector for washing devices

Data

Material	PP
Connection dimension	6/4" Cap nut
Outlet dimension	HL100/40: DN40 HL100/50: DN50
Standard	EN 274
Recommended for	Kitchen sinks with dishwasher
Additional information	Adjustable immersion tube and ball joint included
	Temperature-resistant up to 95°C

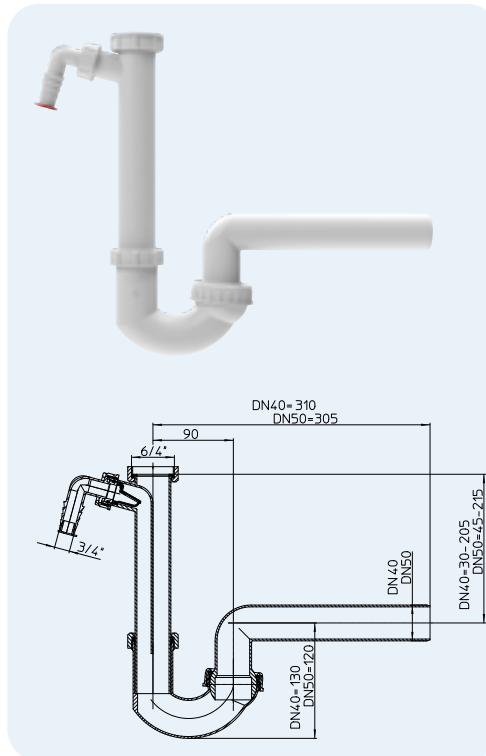

HL-No.	Dimension	Weight	EAN	Piece/package
100/40	DN40	260 g	+110049	10
100/50	DN50	265 g	+110056	10

HL100G Tubular trap

Data

Material	PP
Connection dimension	6/4" Cap nut
Outlet dimension	HL100G/40: DN40 HL100G/50: DN50
Standard	EN 274
Recommended for	Kitchen sink
Additional information	Adjustable immersion tube and ball joint included
	Temperature-resistant up to 95°C

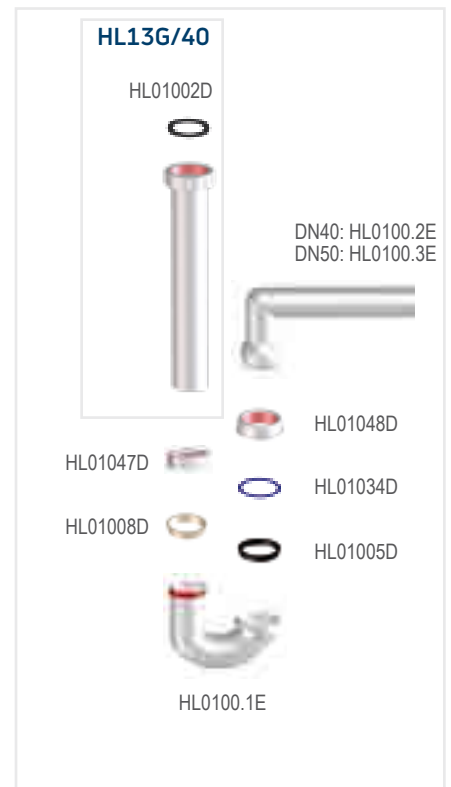
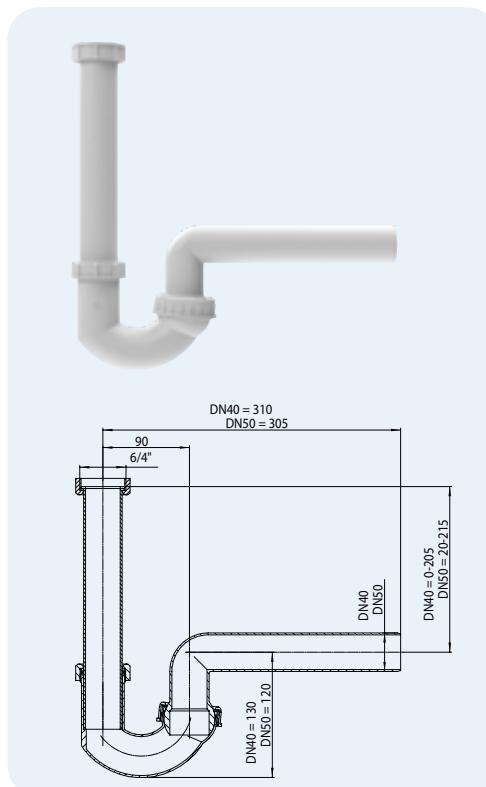

HL-No.	Dimension	Weight	EAN	Piece/package
100G/40	DN40	220 g	+110841	10
100G/50	DN50	225 g	+110858	10

HL126 Space saving trap with backwater membrane connector

Data

Material	PP
Connection dimension	6/4" Cap nut
Outlet dimension	HL126/40: DN40 HL126/50: DN50
Standard	EN 274
Recommended for	Kitchen sinks with dishwasher
Additional information	Adjustable immersion tube and ball joint included
	Temperature-resistant up to 95°C

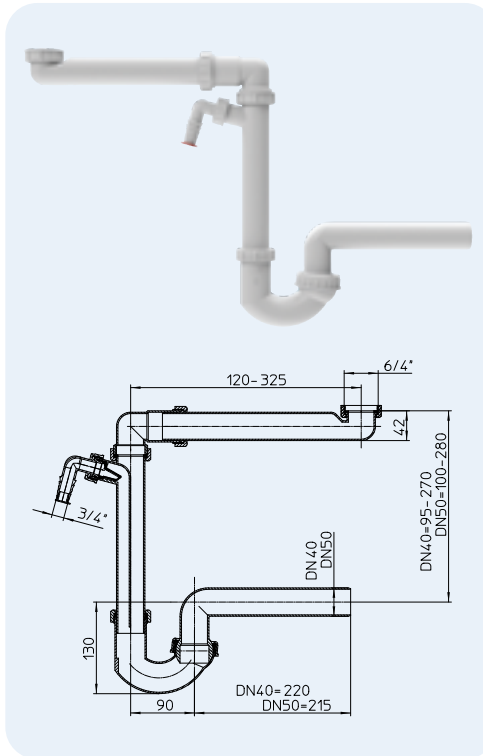

HL-No.	Dimension	Weight	EAN	Piece/package
126/40	DN40	385 g	+013890	10
126/50	DN50	395 g	+013913	10

HL126.2 Space saving trap with backwater membrane connector for double sinks

Data

Material	PP
Connection dimension	2 x 6/4" Cap nut
Outlet dimension	HL126.2/40: DN40 HL126.2/50: DN50
Standard	EN 274
Recommended for	Double kitchen sinks and dishwasher
Additional information	Adjustable immersion tube and ball joint included
	Temperature-resistant up to 95°C

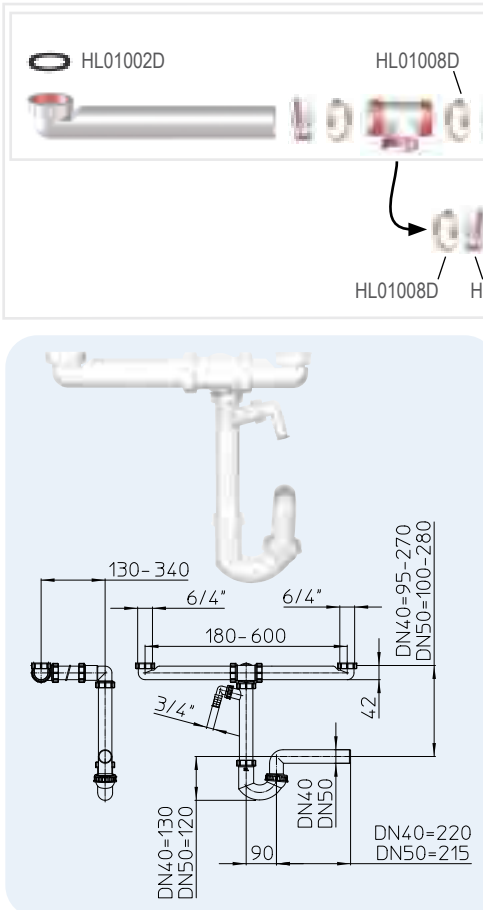

HL-No.	Dimension	Weight	EAN	Piece/package
126.2/40	DN40	580 g	+013654	1
126.2/50	DN50	590 g	+013944	1

HL Kitchen siphons – Accessories – Data

HL3 Non-return valve

Data	
Material	PP
Connection dimension	3/4" Hose nozzle (17 – 23 mm)
Outlet dimension	1"
Recommended for	Dishwasher connector without backwater membrane
Additional information	Prevents from backwater to the washing device, Temperature-resistant up to 95°C

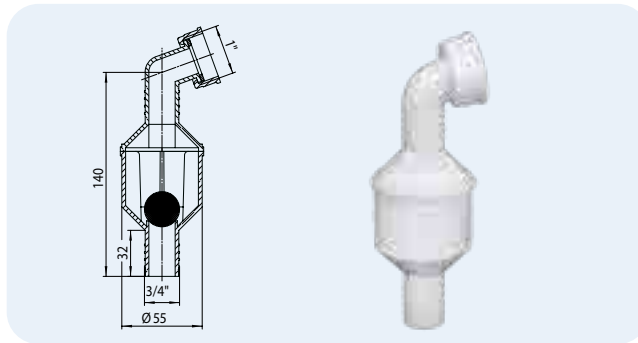

HL-No.	Dimension	Weight	EAN	Piece/package
3		60 g	+500031	1

HL6 Double connector with 2 hose nozzles HL19

Data	
Material	PP
Connection dimension	2 x 3/4" Hose nozzle (17 – 23 mm)
Outlet dimension	6/4" Male thread
Standard	EN 274
Recommended for	Connection of 2 washing devices
Additional information	Temperature-resistant up to 95°C

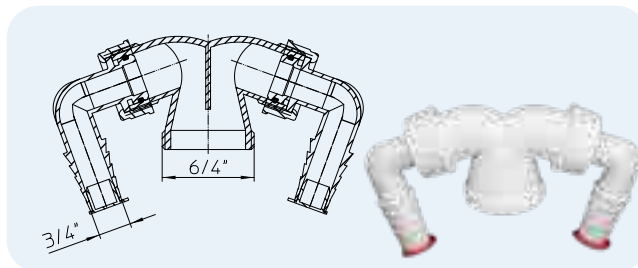

HL-No.	Dimension	Weight	EAN	Piece/package
6		60 g	+500062	1

HL8EL Flexible covering rosette

Data	
Material	PP-soft
Connection dimension	HL8EL/30: DN32 HL8EL/40: DN40 HL8EL/50: DN50
Outlet dimension	HL8EL/30: DN32 HL8EL/40: DN40 HL8EL/50: DN50
Recommended for	the covering of the connection between siphon and wall inlet pipe
Additional information	Flexible version, fits to both pipe and wall

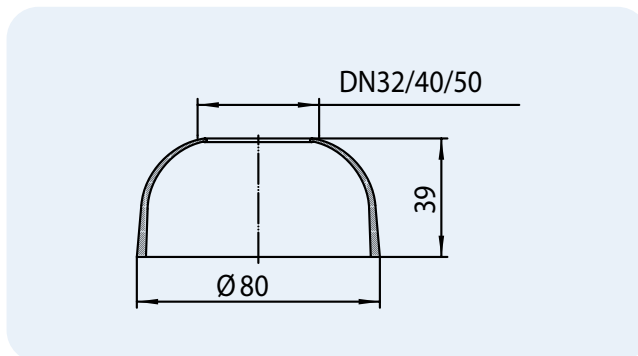

HL-No.	Dimension	Weight	EAN	Piece/package
8EL/30	DN32	8 g	+100835	10
8EL/40	DN40	10 g	+100842	10
8EL/50	DN50	15 g	+100859	10

HL10 Extension tube

Data	
Material	PP
Connection dimension	HL10/40: DN40 Socket HL10/50: DN50 Socket
Outlet dimension	HL10/40: DN40 Pipe HL10/50: DN50 Pipe
Standard	EN 274
Recommended for	Extending of siphons installed on the wall
Additional information	Pull-out save by a wedge shaped gasket and cap nut.

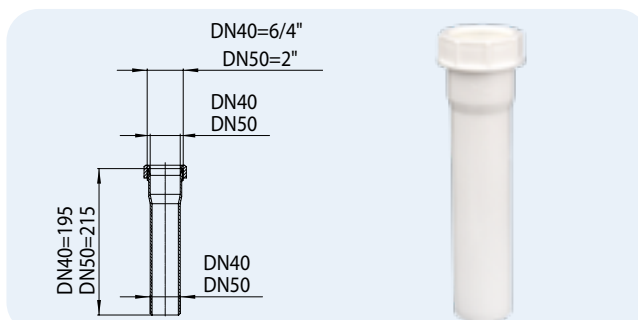

HL-No.	Dimension	Weight	EAN	Piece/package
10/40	DN40	60 g	+100101	10
10/50	DN50	65 g	+110100	10

HL11 90° angled elbow

Data

Material	PP
Connection dimension	HL11/40: DN40 Socket HL11/50: DN50 Socket
Outlet dimension	HL11/40: DN40 Pipe HL11/50: DN50 Pipe
Standard	EN 274
Recommended for	Extending of siphons installed on the wall
Additional information	Pull-out save by a wedge shaped gasket and cap nut.

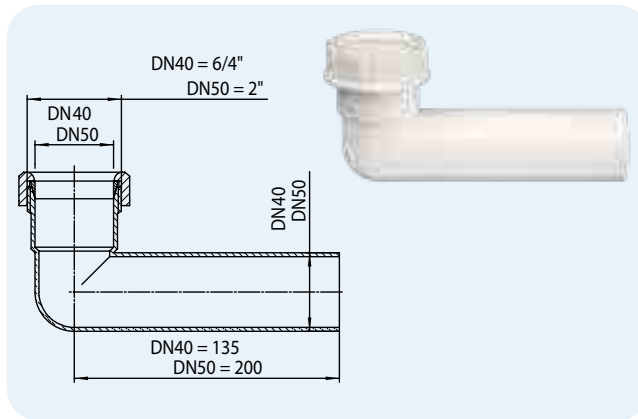

HL-No.	Dimension	Weight	EAN	Piece/package
11/40	DN40	60 g	+100118	10
11/50	DN50	65 g	+110117	10

HL12 Adapter ring

Data

Material	PP
Connection dimension	HL12.1: 5/4"IG x 6/4" Male thread HL12.2: 6/4"IG x 6/4" Male thread HL12.3: 6/4"IG x 5/4" Male thread HL12.4: 2"IG x 6/4" Male thread HL12.5: 5/4"IG x 5/4" Male thread
Standard	EN 274
Recommended for	Extension or reduction of threaded connectors
Additional information	Usage only for non-pressure pipes!

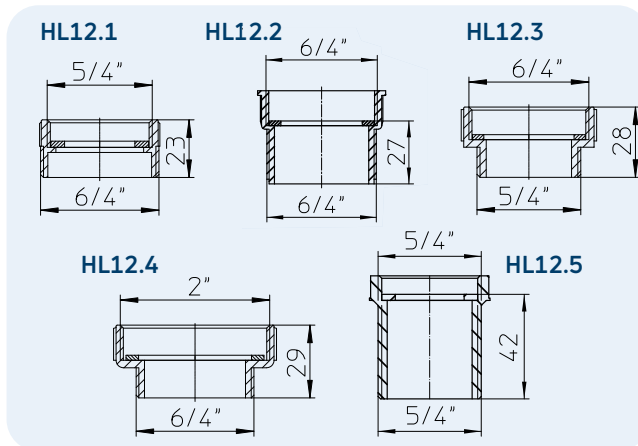

HL-No.	Dimension	Weight	EAN	Piece/package
12.1	5/4" x 6/4"	12 g	+100125	10
12.2	6/4" x 6/4"	20 g	+101221	10
12.3	6/4" x 5/4"	27 g	+101238	10
12.4	2" x 6/4"	20 g	+101245	10
12.5	5/4" x 5/4"	16 g	+051540	10

HL13 Immersion tube with washing device hose nozzles

Data

Material	PP
Connection dimension	HL13/30: 5/4" Cap nut HL13/40: 6/4" Cap nut HL13/50: 6/4" Cap nut
Outlet dimension	HL13/30: DN32 HL13/40: DN40 HL13/50: DN50
Standard	EN 274
Recommended for	To create a washing device connection to the siphon
Additional information	Backwater save, minimal sound by double wall

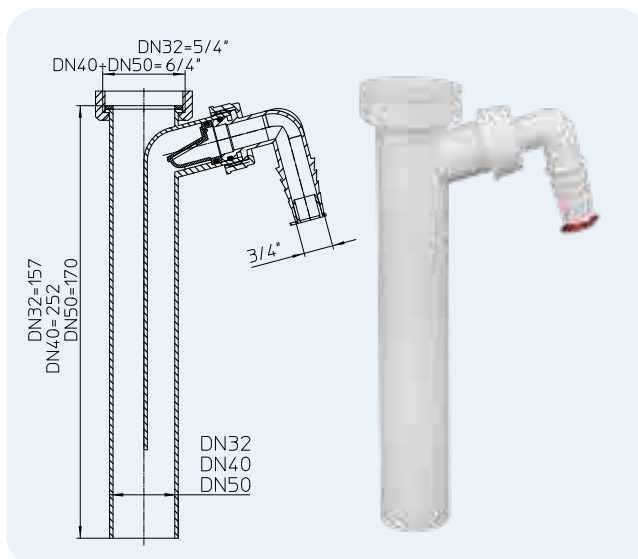

HL-No.	Dimension	Weight	EAN	Piece/package
13/30	DN32 x 5/4"	100 g	+101337	10
13/40	DN40 x 6/4"	110 g	+101344	10
13/50	DN50 x 6/4"	115 g	+101351	10

HL13-2/40 Immersion tube with 2 washing device hose nozzles
Data

Material	PP
Connection dimension	6/4" cap nut
Outlet dimension	DN40
Standard	EN 274
Recommended for	Connection of 2 washing devices
Additional information	Problem solver, if single connectors are missing

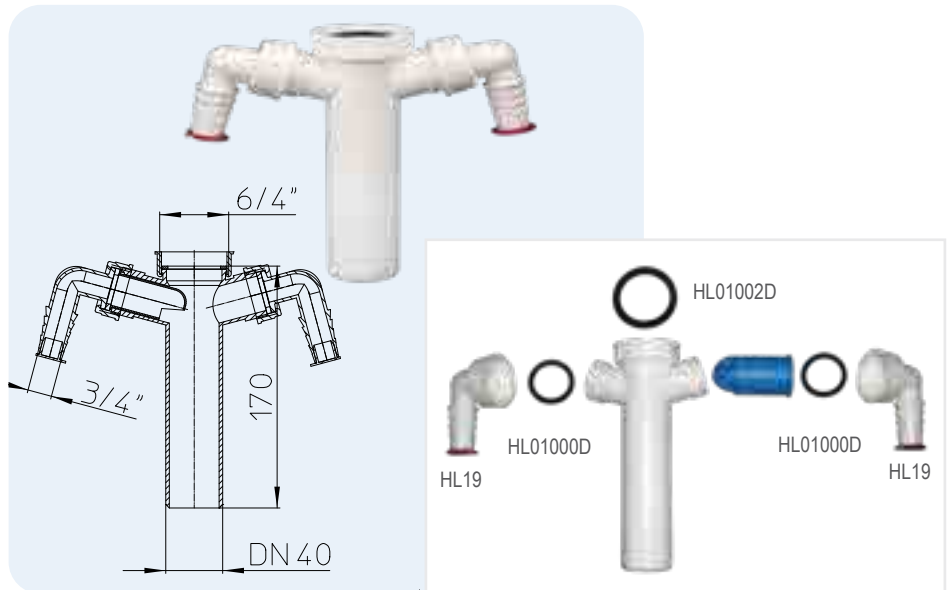

HL-No. 13-2/40	Dimension DN40 x 6/4"	Weight 100 g	EAN +132409	Piece/package 10
-------------------	--------------------------	-----------------	----------------	---------------------

HL13G Immersion tube
Data

Material	PP
Connection dimension	HL13G/30: 5/4" Cap nut HL13G/40: 6/4" Cap nut HL13G/50: 6/4" Cap nut
Outlet dimension	HL13G/30: DN32 HL13G/40: DN40 HL13G/50: DN50
Standard	EN 274
Recommended for	Connector to the kitchen siphon
Additional information	Universally usable

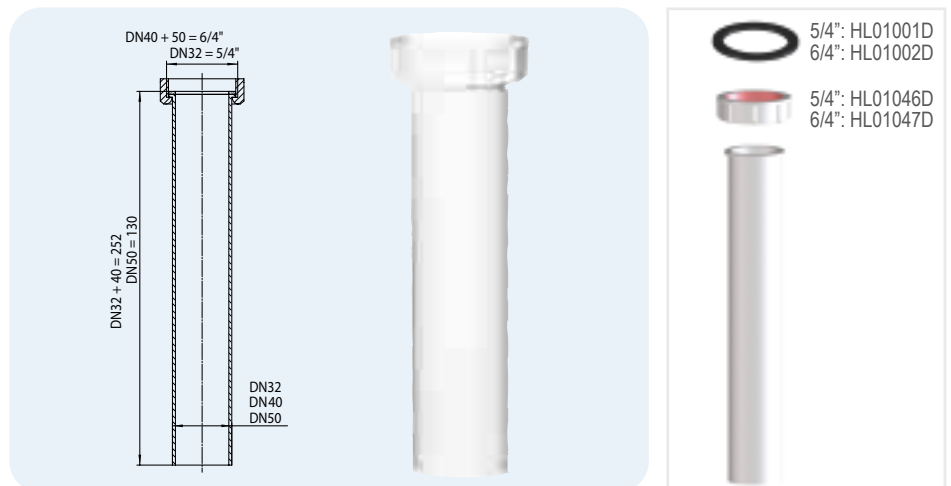

HL-No. 13G/30	Dimension DN32 x 5/4"	Weight 70 g	EAN +111336	Piece/package 10
13G/40	DN40 x 6/4"	80 g	+111343	10
13G/50	DN50 x 6/4"	85 g	+111398	10

HL14/90 Waste outlet
Data

Material	PP/stainless steel
Outlet dimension	6/4" male thread
Standard	EN 274
Recommended for	Kitchen sinks with outlet 90mm (3")
Additional information	Stainless steel valve disc Ø 113 mm and stainless steel plug included As accessory: Screw 7 cm Article No.: HL014/90.5E

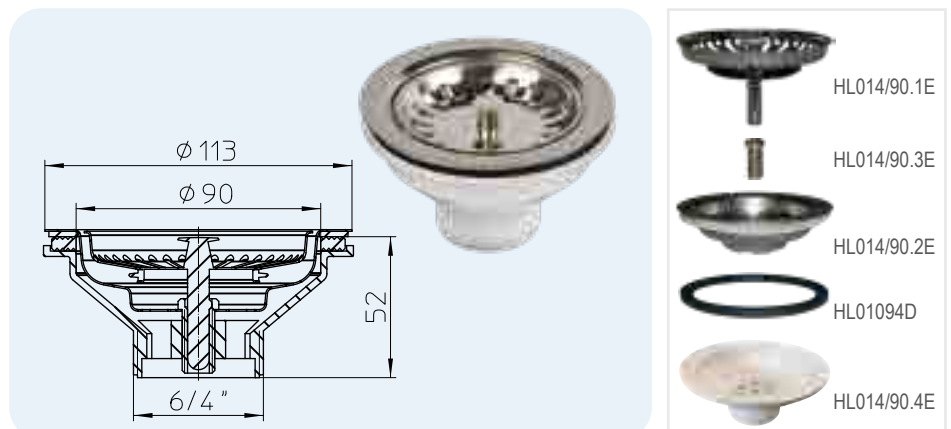

HL-No. 14/90	Dimension 6/4"	Weight 187 g	EAN +026289	Piece/package 1
-----------------	-------------------	-----------------	----------------	--------------------

HL15 Waste outlet

Data

Material	PP/stainless steel
Connection dimension	HL15-5/4": 5/4" Waste outlet HL15-6/4": 6/4" Waste outlet
Outlet dimension	HL15-5/4": 6/4" male thread HL15-6/4": 6/4" male thread
Standard	EN 274
Recommended for	Kitchen sinks with outlet 50mm (6/4") or 40mm (5/4")
Additional information	Valve disc and plug included

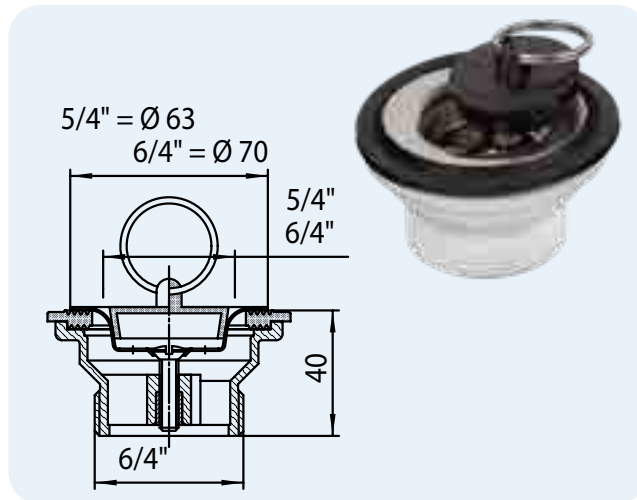

HL-No.	Dimension	Weight	EAN	Piece/package
15-5/4	5/4" x 6/4"	80 g	+101559	10
15-6/4	6/4" x 6/4"	90 g	+100156	10

HL15U Waste outlet with overflow, valve disc and plug

Data

Material	PP/stainless steel
Connection dimension	HL15U-5/4": 5/4" Waste outlet HL15U-6/4": 6/4" Waste outlet
Outlet dimension	HL15U-5/4": 6/4" male thread HL15U-6/4": 6/4" male thread
Recommended for	Kitchen sinks with outlet 50mm (6/4") or 40mm (5/4") with overflow
Additional information	Fits to standard overflow holes

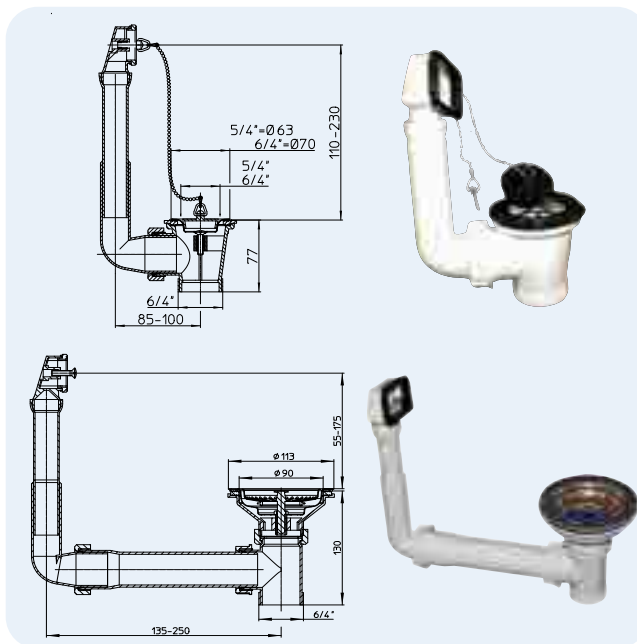

HL-No.	Dimension	Weight	EAN	Piece/package
15U-5/4	5/4" x 6/4"	200 g	+105755	5
15U-6/4	6/4" x 6/4"	210 g	+100576	5
15U-90	Ø 90 x 6/4"	370 g	+035892	1

HL22 Outlet connector

Data

Material	PP
Connection dimension	6/4" Cap nut
Outlet dimension	6/4" male thread
Standard	EN 274
Recommended for	Double kitchen sinks
Additional information	Adjustment 160 – 600 mm

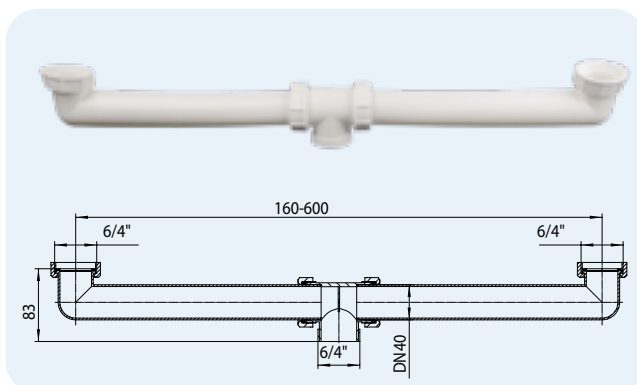

HL-No.	Dimension	Weight	EAN	Piece/package
22	DN40 x 6/4"	200 g	+100224	1

HL23 Outlet connector

Data

Material	PP
Connection dimension	6/4" Cap nut
Outlet dimension	6/4" male thread
Standard	EN 274
Recommended for	Double kitchen sinks
Additional information	Adjustment 85 – 325 mm

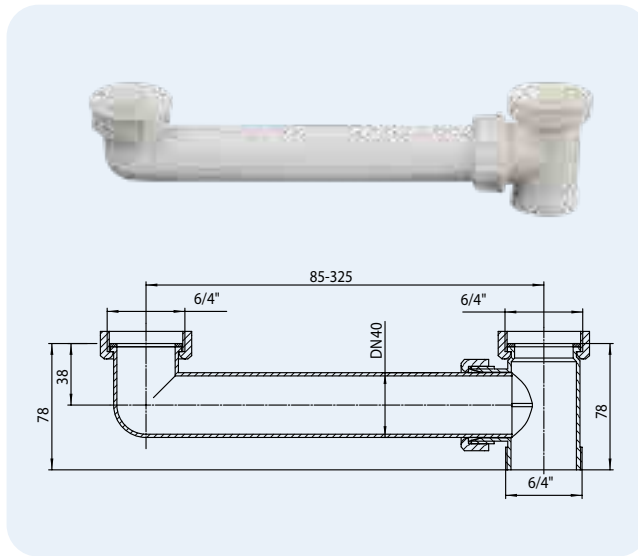

HL-No. 23	Dimension DN40	Weight 125 g	EAN +100231	Piece/package 10
--------------	-------------------	-----------------	----------------	---------------------

HL24 Outlet connector

Data

Material	PP/stainless steel
Connection dimension	HL24-5/4": 5/4" Waste outlet HL24-6/4": 6/4" Waste outlet
Outlet dimension	HL24-5/4": 6/4" male thread HL24-6/4": 6/4" male thread
Standard	EN 274
Recommended for	Double sinks
Additional information	With valve disc and plug

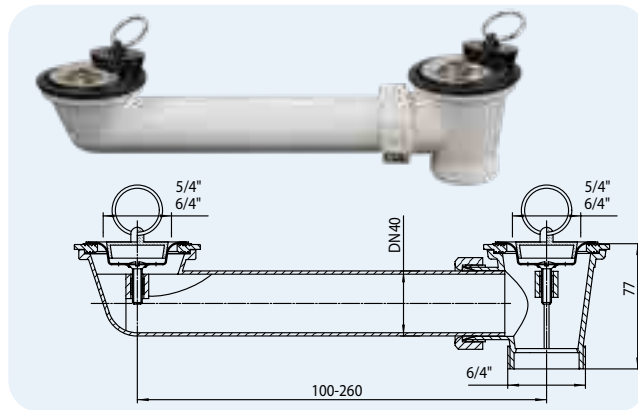

HL-No. 24-5/4 24-6/4	Dimension DN40 x 5/4" DN40 x 6/4"	Weight 125 g 135 g	EAN +102457 +100248	Piece/package 10 10
----------------------------	---	--------------------------	---------------------------	---------------------------

HL24U Outlet connector

Data

Material	PP/stainless steel
Connection dimension	HL24U-5/4": 2 x 5/4" Waste outlet HL24U-6/4": 2 x 6/4" Waste outlet
Outlet dimension	HL24U-5/4": 6/4" male thread HL24U-6/4": 6/4" male thread
Standard	EN 274
Recommended for	Double sinks with outlet 50mm (6/4") or 40mm (5/4")
Additional information	With valve disc, outlet and plug Fits to standard overflow holes Adjustment 100 – 260 mm

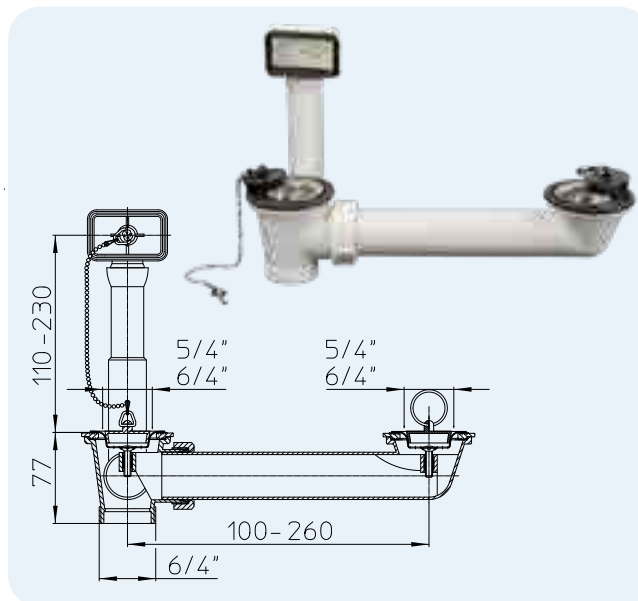

HL-No. 24U-5/4 24U-6/4	Dimension DN40 x 5/4" DN40 x 6/4"	Weight 360 g 370 g	EAN +124756 +112470	Piece/package 5 5
------------------------------	---	--------------------------	---------------------------	-------------------------

HL25U Outlet connector for reversible double sinks

Data

Material	PP/stainless steel
Connection dimension	2 x 6/4" Waste outlet
Outlet dimension	6/4" male thread
Standard	EN 274
Recommended for	Double sinks with outlet 50mm (6/4") or 40mm (5/4")
Additional information	With valve disc, outlet and plug Fits to standard overflow holes

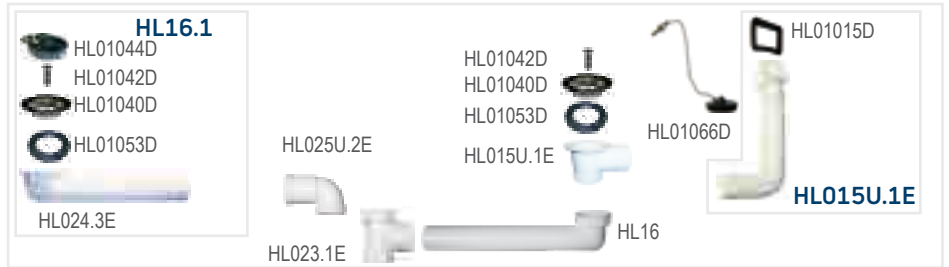
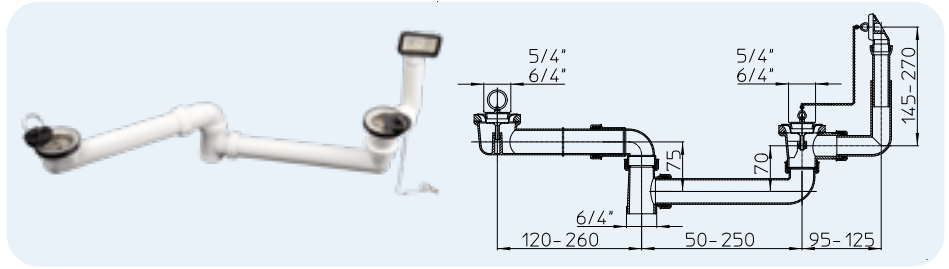

HL-No. 25U-6/4	Dimension DN40 x 6/4"	Weight 500 g	EAN +925643	Piece/package 1
-------------------	--------------------------	-----------------	----------------	--------------------

HL26 Space saving connector

Data

Material	PP
Connection dimension	6/4" Cap nut
Outlet dimension	6/4" male thread
Standard	EN 274
Recommended for	Space saving placement of the siphon
Additional information	For converting HL100 to HL126

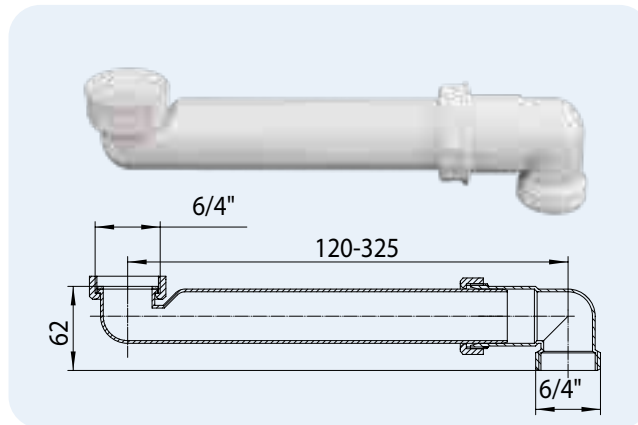

HL-No. 26	Dimension DN40 x 6/4"	Weight 128 g	EAN +100262	Piece/package 10
--------------	--------------------------	-----------------	----------------	---------------------

HL27 Outlet connector

Data

Material	PP
Connection dimension	2 x 6/4" Cap nut
Outlet dimension	6/4" male thread
Standard	EN 274
Recommended for	Double sinks with height offset

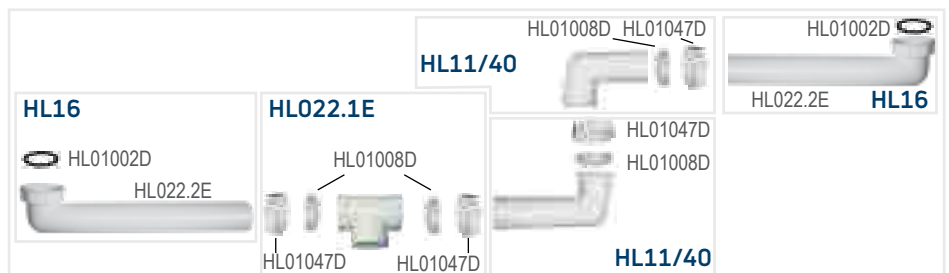
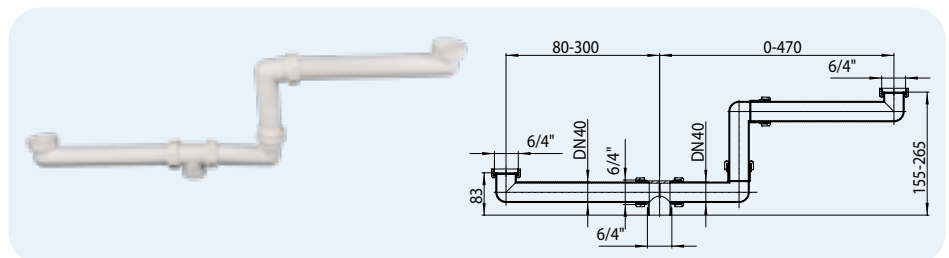

HL-No. 27	Dimension DN40 x 6/4"	Weight 332 g	EAN +100279	Piece/package 1
--------------	--------------------------	-----------------	----------------	--------------------

HL28 Outlet connector

Data

Material	PP
Connection dimension	3 x 6/4" Cap nut
Outlet dimension	6/4" male thread
Standard	EN 274
Recommended for	Double sinks with height offset

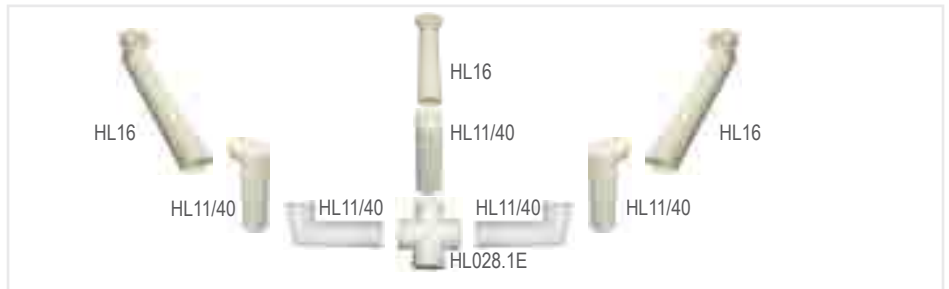
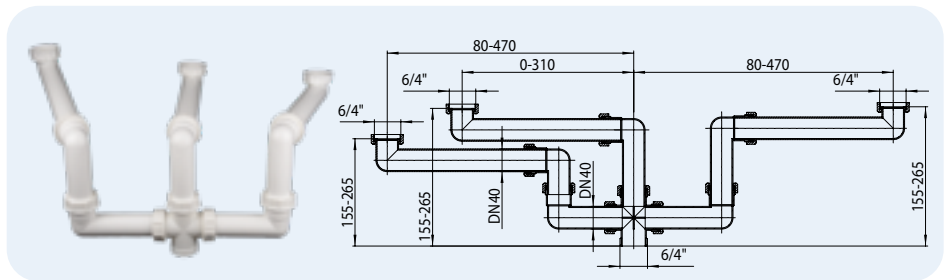

HL-No.	Dimension	Weight	EAN	Piece/package
28	DN40 x 6/4"	575 g	+100286	1



SIPHONS ABLÄUFE

DN40 = 80-315

DN32 = 80-315

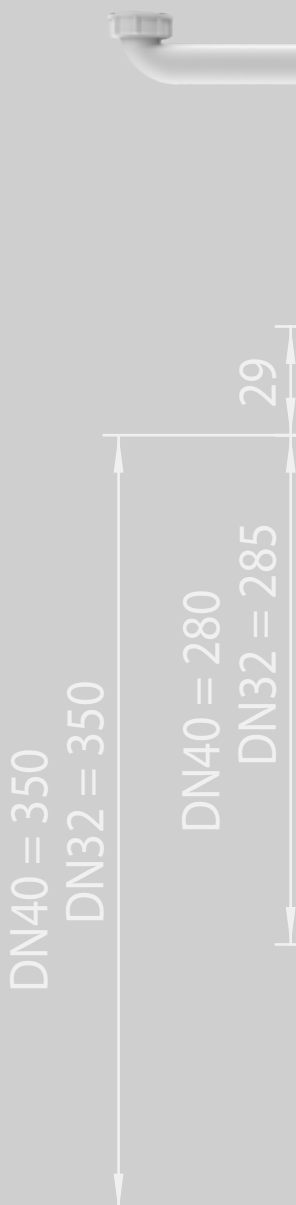

DN40
DN32

DN40 = 95
DN32 = 90



HL Siphons

2. Washbasin

2



HL Washbasin traps

Basic information about design and installation

Siphons made of plastic, e.g. polypropylene, have different advantages compared to conventional metal siphons:

▲ Convenient in installation

The length adjustment of plastic parts is much faster and saver than of metal parts. Because of the material properties of plastic, gaskets and nuts may be opened and closed tightly time after time, only by screwing by hand.

▲ Easy to maintain

HL washbasin siphons are mostly equipped with cleaning possibilities. Cleaning trays may be removed and cleaned with little effort and without tools. Items like jewellery, which fell into the trap, cannot get into the drain pipe.

▲ Space saving and handicap-accessible

Most washbasins nowadays are furnished with bathroom cabinets. As the siphon is invisible, it has not to fit to the bathroom design. To get more usable space under the washbasin, the siphon should be situated near the wall (possible with HL137). Also these traps simplify the access to the washbasin for disabled people with wheelchairs (HL137 and HL134.0 OR HL4000 and HL4000.3).

▲ Flexibility

As the connection between washbasin, trap and the wall-side inlet is mostly not in line with the waste outlet, it is necessary with standard traps to use bows to reach the waste pipe. By using traps with rotating connections the plumber saves these additional fittings. If there are no separate connections for washing appliances (HL400 series), the space-saving washbasin trap with washing appliance connection HL137N-WM can be used. The space-saving washbasin trap HL137N-BV with integrated ventilation valve is ideal as a solution for drains that suck dry or gurgle.

Relevant standards/directives

EN 274.....Drains and siphons for sanitary equipment
DIN 19541Siphons for special purposes

HL Washbasin siphons – Products – Overview

Siphons

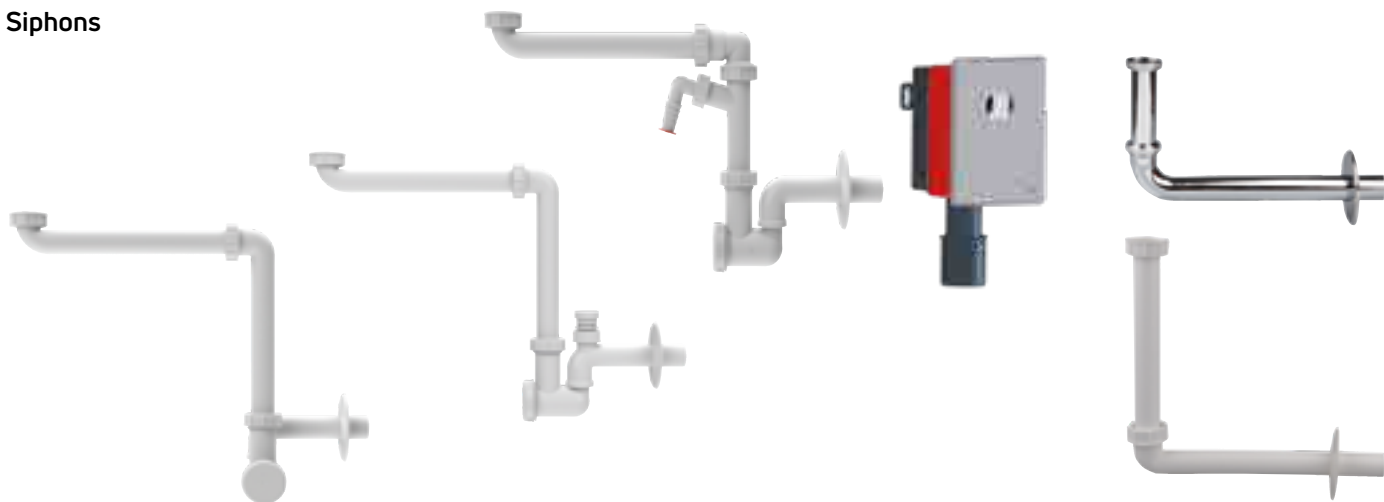

Product	HL137N	HL137N-BV	HL137N-WM	HL4000.0 HL4000.3	HL134.1C HL134.1K
Description	Space saving trap	Space saving trap with air admittance valve	Space saving trap with washing device connection	Washer/wash basin construction set	Installation kit for HL134.0
Function	For the space saving and handicap-accessible siphoning of washbasins	For ventilation of drainage points without loss of space thanks to space-saving design	For the space-saving connection of washing devices	Flush mounted odour trap (basin accessible for handicapped people)	Connection between the flush mounted siphon HL134.0 and the washbasin

HL Washbasin traps – Products – Data

HL132 Washbasin trap

Data

Material	PP
Connection dimension	5/4" Cap nut
Outlet dimension	HL 132/30: DN32 HL 132/40: DN40 horizontal
Standard	EN 274
Recommended for	replacement of standard metal siphons, temperature-resistant up to 95 °C
Including	Adjustable immersion tube, rosette

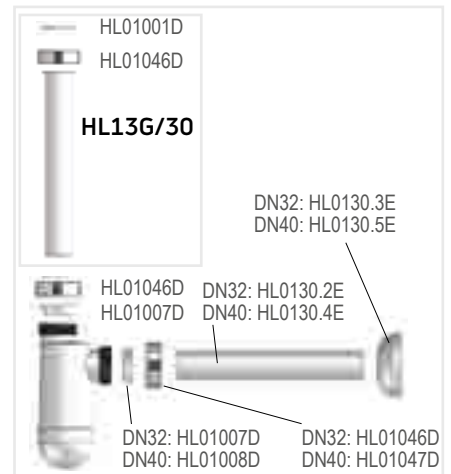
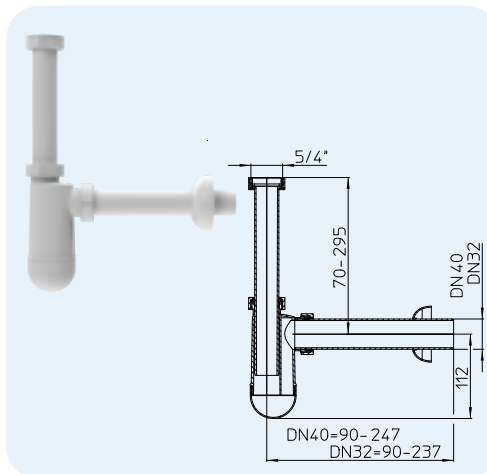

HL-No.	Dimension	Weight	EAN	Piece/package
132/30	DN32 x 5/4"	180 g	+301324	1
132/40	DN40 x 5/4"	185 g	+321322	1

HL132.1 Washbasin trap with hose nozzle

Data

Material	PP
Connection dimension	5/4" Cap nut
Outlet dimension	HL 132.1/30: DN32 HL 132.1/40: DN40 horizontal
Standard	EN 274
Recommended for	temperature-resistant up to 95 °C
Including	Adjustable immersion tube, rosette, backwater membrane hose nozzle

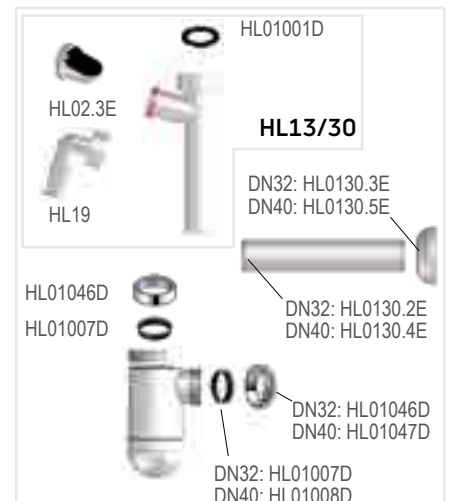
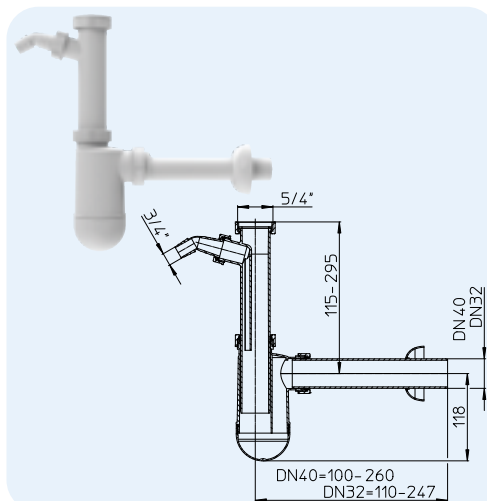

HL-No.	Dimension	Weight	EAN	Piece/package
132.1/30	DN32 x 5/4"	220 g	+899999	10
132.1/40	DN40 x 5/4"	225 g	+999996	10

HL133 Washbasin trap with hose nozzle and cleaning tray

Data

Material	PP
Connection dimension	5/4" Cap nut
Outlet dimension	HL 133/30: DN32 HL 133/40: DN40 horizontal, rotatable
Standard	EN 274
Recommended for	temperature-resistant up to 95 °C
Including	Adjustable immersion tube, rosette, backwater membrane hose nozzle, cleaning tray : relieves the retrieving of lost jewellery

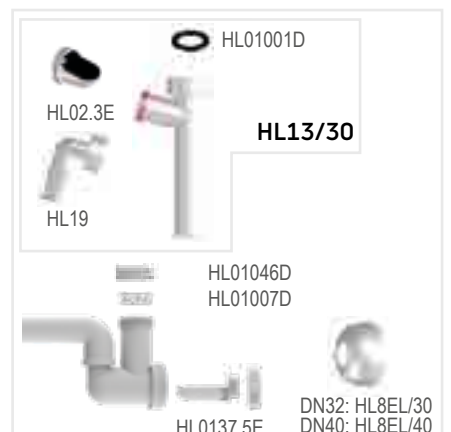
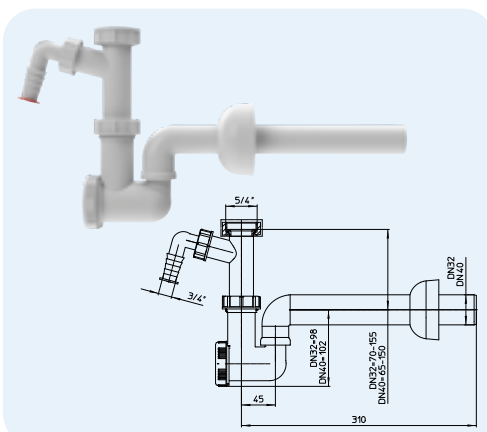

HL-No.	Dimension	Weight	EAN	Piece/package
133/30	DN32	220 g	+321339	10
133/40	DN40	225 g	+301331	10

HL134.0 Flush mounted washbasin trap

Data

Capacity	HL 134.0/40: 0,38 l/s HL 134.0/50: 0,38 l/s
Material	PP
Connection dimens.	DN32
Outlet dimension	HL 134.0/40: DN40 HL 134.0/50: DN50 vertical
Standard	DIN 19541
Recommended for	Flush mounted siphon for washbasins, in combination with HL 134.1C or 134.1K; for handicap-accessible washbasins
Including	Inlet element for easy cleaning of the siphon; relieves the access to the waste pipe

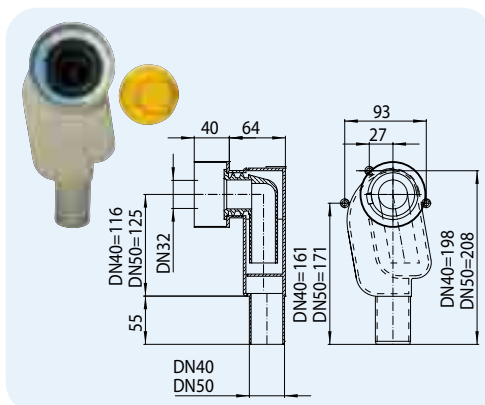

HL-No.	Dimension	Weight
134.0/40	DN40	380 g
134.0/50	DN50	385 g

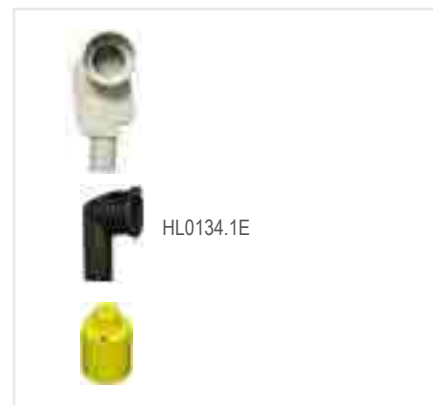

HL134.1E

EAN	Piece/package
+301348	10
+302345	10

HL134.1C Brass connector, chrome-plated

Data

Material	Brass, chrome-plated
Connection dimension	5/4" Cap nut
Outlet dimension	DN32 horizontal
Standard	EN 274
Recommended for	Connection between flush mounted siphon HL 134.0 and the washbasin
Including	Adjustable immersion tube

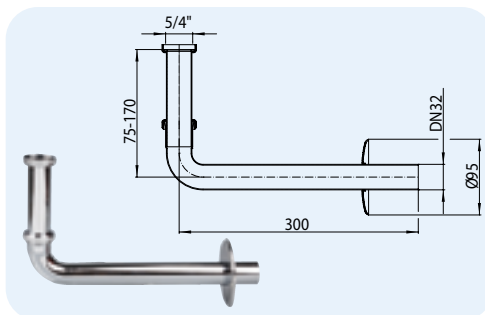

HL-No.	Dimension	Weight
134.1C	DN32 x 5/4"	290 g



HL1001D

HL101069D

HL10134.4E

EAN	Piece/package
+311347	10

HL134.1K Plastic connector

Data

Material	PP
Connection dimens.	5/4" Cap nut
Outlet dimension	DN32 horizontal
Standard	EN 274
Recommended for	Connection between flush mounted siphon HL 134.0 and the washbasin; temperature-resistant up to 95 °C
Including	Adjustable immersion tube

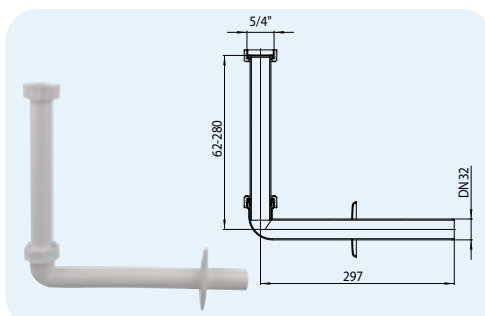

HL-No.	Dimension	Weight
134.1K	DN32 x 5/4"	140 g

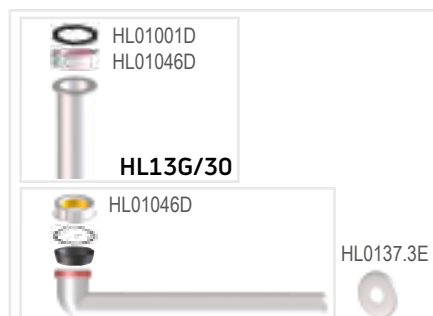

HL1001D

HL101046D

HL13G/30

HL101046D

HL10137.3E

EAN	Piece/package
+313341	10

HL135 Washbasin and bidet trap

Data

Material	PP
Connection dimension	5/4" Cap nut
Outlet dimension	HL 135/30: DN32 HL 135/40: DN40 horizontal, rotatable
Standard	EN 274
Recommended for	Washbasins and bidets, temperature-resistant up to 95 °C
Including	Adjustable immersion tube, cleaning tray; relieves the retrieving of lost jewellery

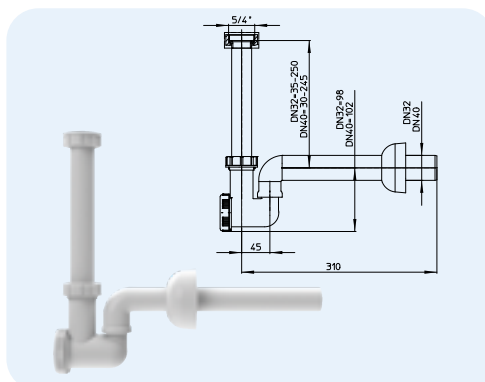

HL-No.	Dimension	Weight
135/30	DN32	215 g
135/40	DN40	220 g

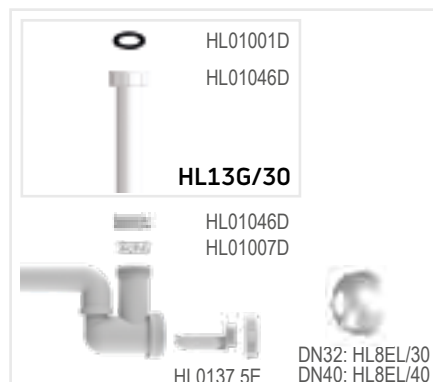

HL1001D

HL101046D

HL13G/30

HL101046D

HL101007D

HL10137.5E

 DN32: HL8EL/30
DN40: HL8EL/40

EAN	Piece/package
+331352	10
+321353	10

HL4000.0 Corpus for washing device trap / wash basin trap
HL4000.3 Wash basin upgrade kit

Data

Capacity	0,6 l/s
Material	PP/Stainless steel
Connection	DN32
Outlet	DN40/50
Siphon height	50 mm
Standard	DIN 19541
Recommended for	siphoning of space saving wash basins or handicap-accessible basins, e.g. for hospitals or retirement homes
Additional information	As connector between siphon and basin we recommend HL134.1K or HL134.1C

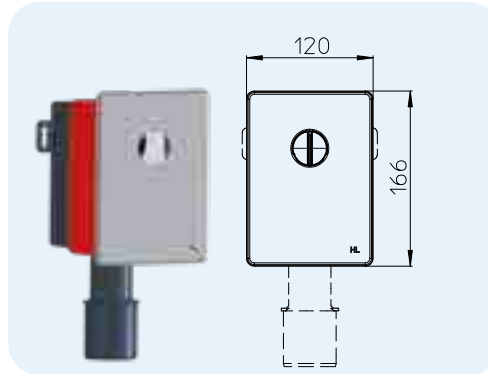

HL-No.	Dimension	Weight	EAN	Piece/package
4000.0	DN40/50	244 g	+041619	1
4000.3	DN40/50	220 g	+041657	1

HL137N Space saving trap, Outlet horizontal

Data

Material	PP
Connection dimension	5/4" Cap nut
Outlet dimension	137N/30: DN32 137N/40: DN40 horizontal
Standard	EN 274
Recommended for	Space saving installation in bathroom furniture; or for handicap-accessible washbasins; temperature-resistant up to 95 °C
Including	cleaning tray: relieves the retrieving of lost jewellery; Adjustable immersion tube

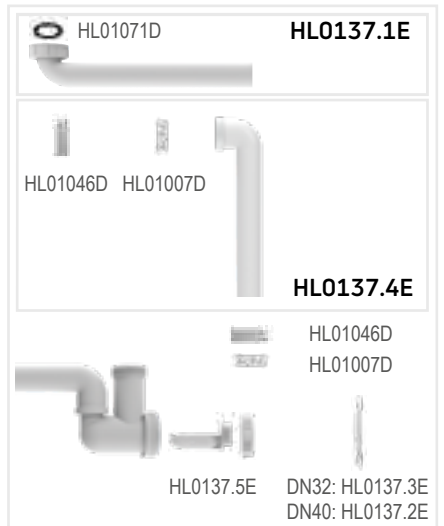
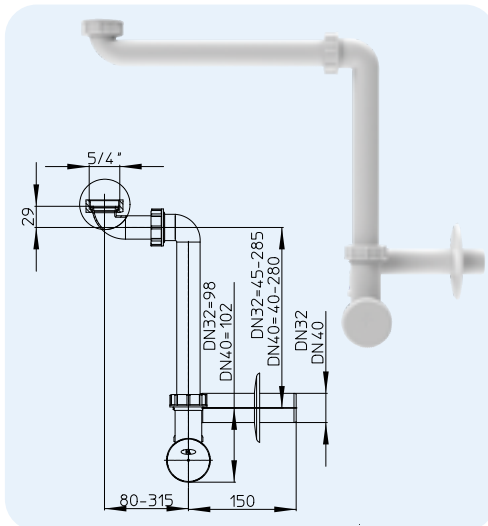

HL-No.	Dimension	Weight	EAN	Piece/package
137N/30	DN32 x 5/4"	300 g	+003976	10
137N/40	DN40 x 5/4"	305 g	+003990	10

HL137N-BV Space-saving trap with air -admittance valve, horizontal outlet

Data

Material	PP
Connection dimension	5/4" Cap nut
Outlet dimension	137N-BV/30: DN32
Standard	EN 274
Recommended for	Space-saving installation in bathroom furniture; or for disabled-friendly washbasins; includes HL902 air -admittance valve 1 inch
Including	Including cleaning tray also makes it easier to find lost jewelry; Adjustable immersion tube integrated HL902 air-admittance valve

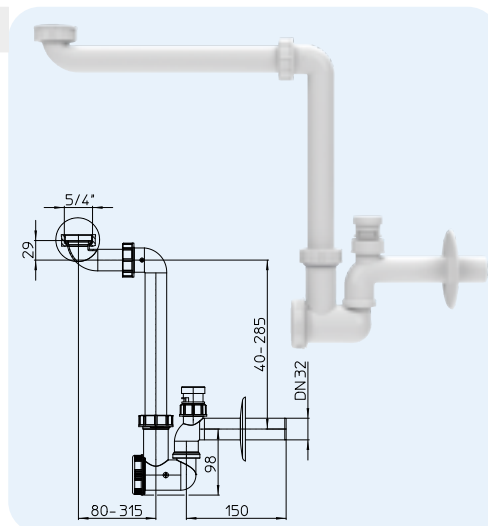

HL-Nr.	Dimension	Gewicht	EAN	Stk./Verp.
137N-BV/30	DN32 x 5/4"	294 g	+002207	10

HL137N-WM Space saving trap with washing device connection, horizontal outlet
Data

Material	PP
Connection dimension	5/4" Cap nut
Outlet dimension	137N-WM/30: DN32 137N-WM/40: DN40
Standard	EN 274
Recommended for	Space-saving installation in bathroom furniture; or for disabled-friendly washbasins; includes HL19 appliance hose connector 1 x 2/4 inch
Including	Including cleaning tray also makes it easier to find lost jewelry; Adjustable immersion tube Integrated HL19 appliance hose connector for easy retrofitting of washing machines

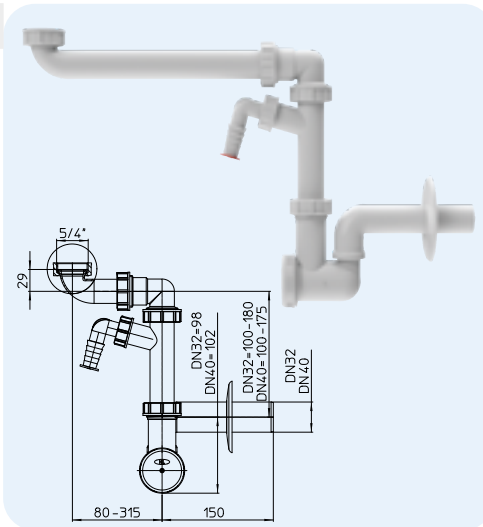

HL-Nr.	Dimension	Gewicht
137N-WM/30	DN32 x 5/4"	292 g
137N-WM/40	DN40 x 5/4"	299 g

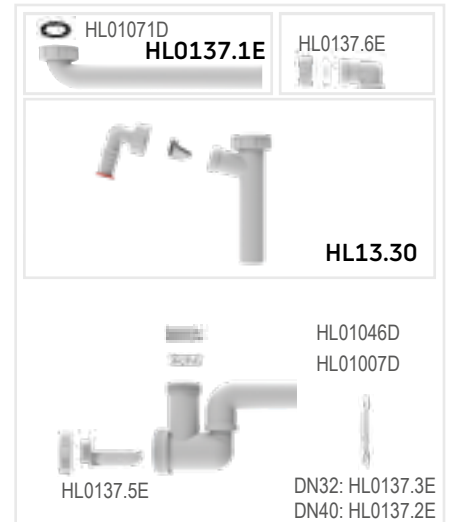

EAN	Stk./Verp.
+002252	10
+002276	10

HL137N.1 Space saving trap, outlet vertical
Data

Material	PP
Connection dimension	5/4" Cap nut
Outlet dimension	137N.1/30: DN32 137N.1/40: DN40 vertical
Standard	EN 274
Recommended for	Space saving installation in bathroom furniture; or for handicap-accessible washbasins; temperature-resistant up to 95 °C
Including	cleaning tray: relieves the retrieving of lost jewellery; Adjustable immersion tube

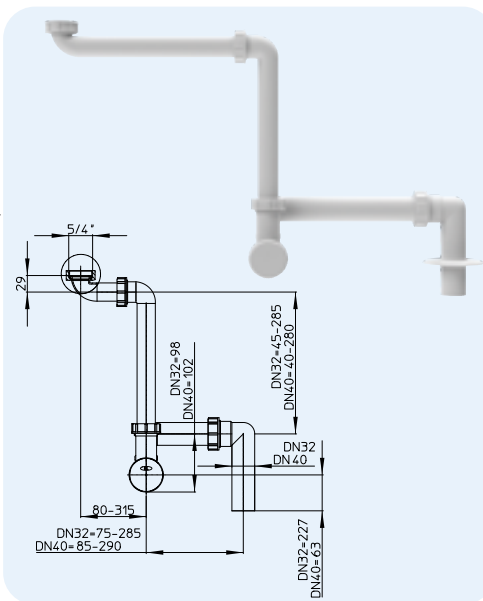

HL-No.	Dimension	Weight
137N.1/30	DN32 x 5/4"	360 g
137N.1/40	DN40 x 5/4"	355 g

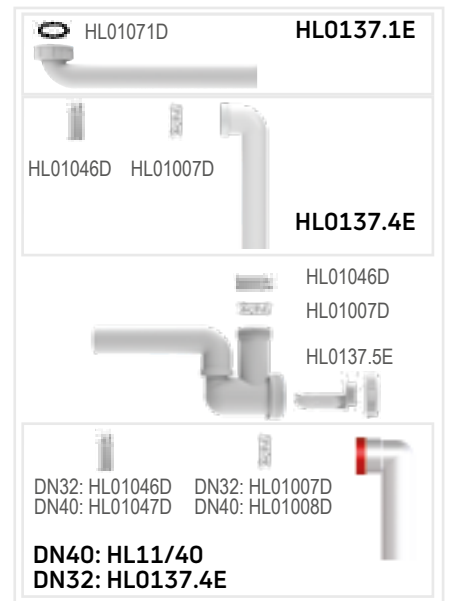

EAN	Piece/package
+006298	10
+006335	10

HL12.5 Thread extension 5/4"
Data

Material	PP
Connection dimension	5/4" inside thread
Outlet dimension	5/4" outside thread
Standard	EN 274
Recommended for	countertop washbasins

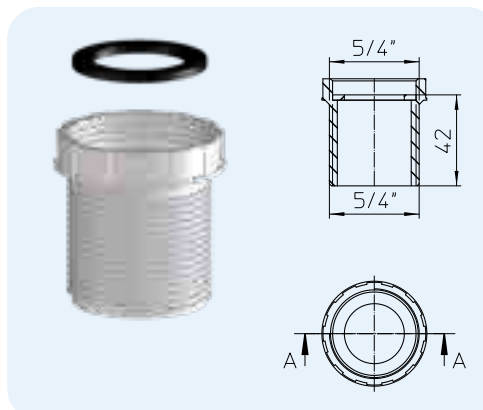

HL-No.	Dimension	Weight
12.5	5/4" IG x 5/4" AG	16 g



EAN	Piece/package
+051540	1

HL15.1 Waste outlet

Data

Material	PP
Connection dimension	5/4" Waste outlet
Outlet dimension	5/4" Thread
Standard	EN 274
Recommended for	Washbasin with integrated overflow
Including	Chain, screw and plug

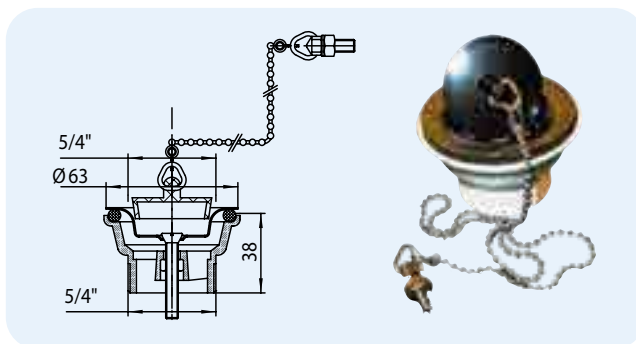

HL-No.	Dimension	Weight	EAN	Piece/package
15.1	5/4" x 5/4"	85 g	+101511	10

HL19T T-connector

Data

Material	PP
Connection dimension	19T: 3/4" Hose nozzle 19T.2: Ø 8 – 13 mm Hose nozzle
Outlet dimension	HL19T(.2)/30: DN32 HL19T(.2)/40: DN40
Standard	EN 274
Recommended for	Subsequent connection to washing devices; exclusively for vertical immersion tubes

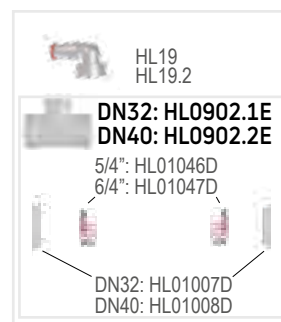
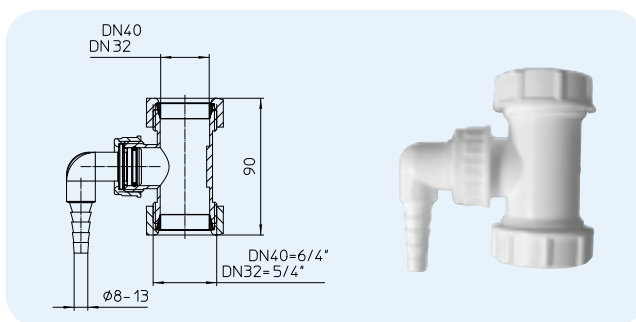

HL-No.	Dimension	Weight	EAN	Piece/package
19T/30	DN32 x 5/4" - 1" x 3/4"	63 g	+004294	1
19T/40	DN40 x 6/4" - 1" x 3/4"	65 g	+004331	1
19T.2/30	DN32 x 5/4" - 1" x 8-13 mm	63 g	+004355	1
19T.2/40	DN40 x 6/4" - 1" x 8-13 mm	65 g	+004348	1

HL34 Angled trap connector

Data

Material	PE
Connection dimension	DN32/40
Outlet dimension	DN40/50
Standard	EN 274
Recommended for	Kitchen and washbasin rear panel installation
Additional information	Inlet side adjustable in length by cutting, connection between siphon and wall outlet

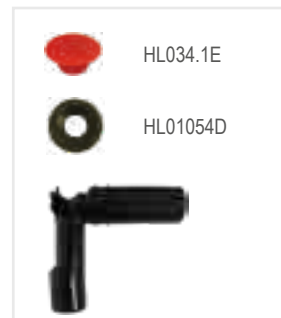
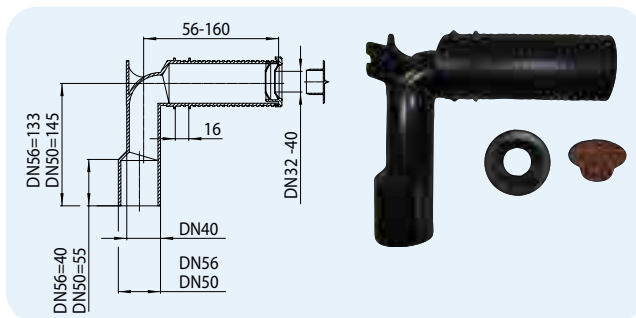

HL-No.	Dimension	Weight	EAN	Piece/package
34	DN40/50	160 g	+940349	10



SIPHONS ABLÄUFE

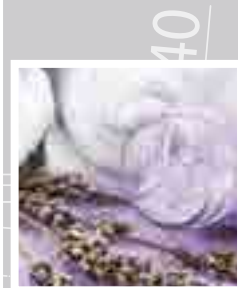

HL Siphons

3. Bath tub

3



Ø 8-1

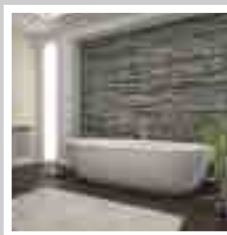

HL Bath tub siphons

Basic information about design and installation

▲ Design: Easy accessibility

If the bath tub is sheeted, please take care to have an access to the siphon for cleaning and maintainance. ATTENTION: Avoid cleaning with compressed air, as the connection parts in the siphon or in the drain pipe may be splitted.

▲ Solid materials

To guarantee a long lifetime of the bath tub sets, HL only uses solid brass parts.

▲ Easy and quick installation

HL bath tub siphons are equipped with rotatable ball joints, which relieves the installation. All outlets of our siphons are connectable to plug-in sleeve pipes or may be welded with PE-pipes.

▲ Important: Leak test

Both drain connection and overflow connection has to be tested on leakness, as a subsequent correction may cause high costs. The leak test can be made allready during construction, as it is not necessary, to install the visible parts in advance.

Relevant standards/directives

EN 274 Drains and siphons for sanitary equipement

HL Bath tub siphons – Products – Overview

Siphons / valves



Product	HL555N	HL555N.L.0	HL560N	HL560N.L
Description	Bath tub waste and overflow set	Bath tub waste and overflow set with bowden cable 80cm, without visible parts	Bath tub waste, overflow and water supply set	Bath tub waste, overflow and water supply set with bowden cable 80cm
Function	For siphoning standard bath tubs, opening and closing of the plug is effected by the integrated turning handle in the overflow unit.	For siphoning bath tubs with longer distance between overflow and outlet, opening and closing of the plug is effected by the integrated turning handle in the overflow unit.	Siphoning, water supply, opening/closing of the plug and overflow is situated in the turning handle.	For bath tubs with longer distance between overflow and outlet. Siphoning, water supply, opening/closing of the plug and overflow is situated in the turning handle.

HL Bath tub siphons – Products – Data

HL555N Bath tub waste and overflow set

Data

Capacity	0,67 l/s
Material	PP, outlet pluggable and weldable
Visible parts	Brass, chrome-plated
Connection dimension	6/4"
Outlet dimension	DN40/50, adjustable in length, horizontal. Ball joint: 280° rotatable, 10° inclinable
Standard	EN 274
Height of seal water	50 mm
Additional information	Mechanism with a toothed rack, turning handle, flexible overflow tube, double gasket for the plug, bowden cable made of stainless steel (CrNi 18/10), additional connection Ø 8 – 13 mm for leakage pipes. Usage for bath tubes with max. material thickness of 13mm

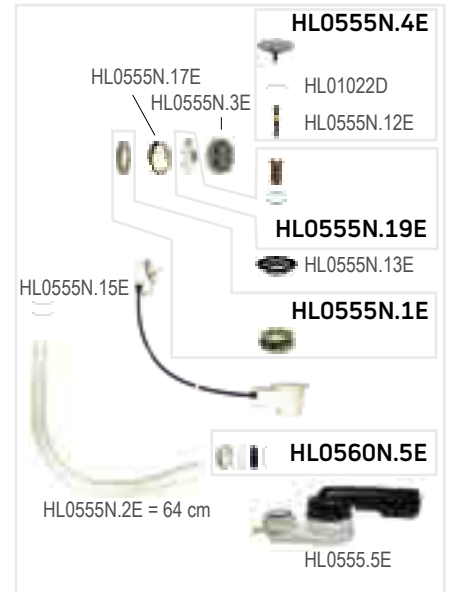
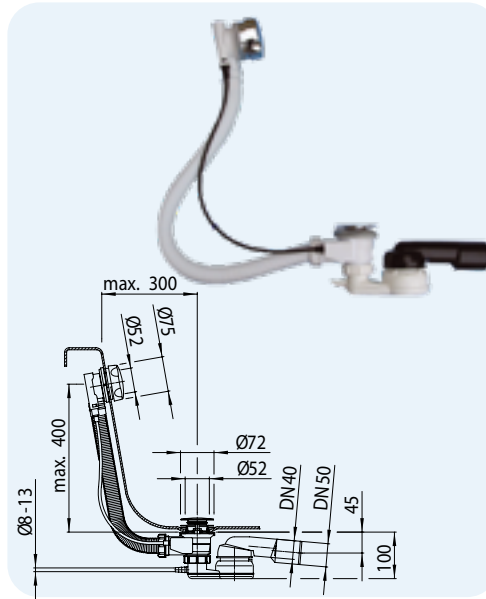

HL-No.	Dimension	Length of the bowden cable	Weight	EAN	Piece/package
555N	DN40/50	60 cm	900 g	+003730	5

HL555N.0, HL555N.L.0 Bath tub waste and overflow set like HL555N, but without visible parts

Data

Capacity	0,67 l/s
Material	PP outlet pluggable and weldable
Visible parts	without visible parts
Connection dimens.	6/4"
Outlet dimension	DN40/50, adjustable in length, horizontal. Ball joint: 280° rotatable, 10° inclinable
Standard	EN 274
Height of seal water	50 mm
Additional information	Mechanism with a toothed rack, turning handle, flexible overflow tube, double gasket for the plug, bowden cable made of stainless steel(CrNi 18/10), additional connection Ø 8 – 13 mm for leakage pipes. Usage for bath tubes with max. material thickness of 13mm

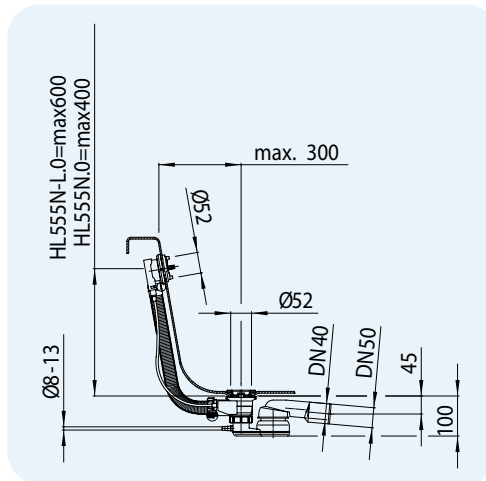

HL-No.	Dimension	Length of the bowden cable	Weight	EAN	Piece/package
555N.0	DN40/50	60 cm	735 g	+003792	5
555N.L.0	DN40/50	80 cm	735 g	+016044	1

HL555N.1 – HL555N.4 Visible parts for the bath tub waste and overflow set HL555N.0 or HL555N.L.0

Data

Material	555N.1: Brass, chrome-plated 555N.2: Solid brass 555N.3: White brass 555N.4: Gold-plated brass
Standard	EN 274



HL-No.	Visible parts	Weight	EAN	Piece/package
555N.1	Brass, chrome-plated	305 g	+003815	1
555N.2	Solid brass	305 g	+003839	1
555N.3	White brass	305 g	+003877	1
555N.4	Gold-plated brass	305 g	+003891	1

HL560N, HL560N.L Bath tub waste and overflow set with integrated water supply
Data

Capacity	0,67 l/s
Material	PP, outlet pluggable and weldable
Visible parts	Brass, chrome-plated
Connection dimension	6/4"
Outlet dimension	DN40/50, adjustable in length, horizontal. Ball joint: 280° rotatable, 10° inclinable
Water supply	integrated , 3/4" connection left or right
Standard	EN 274
Height of seal water	50 mm
Additional information	Mechanism with a toothed rack, turning handle, flexible overflow tube, double gasket for the plug, bowden cable made of stainless steel(CrNi 18/10), additional con- nection Ø 8 – 13 mm for leakage pipes. Usage for bath tubes with max. material thickness of 13mm

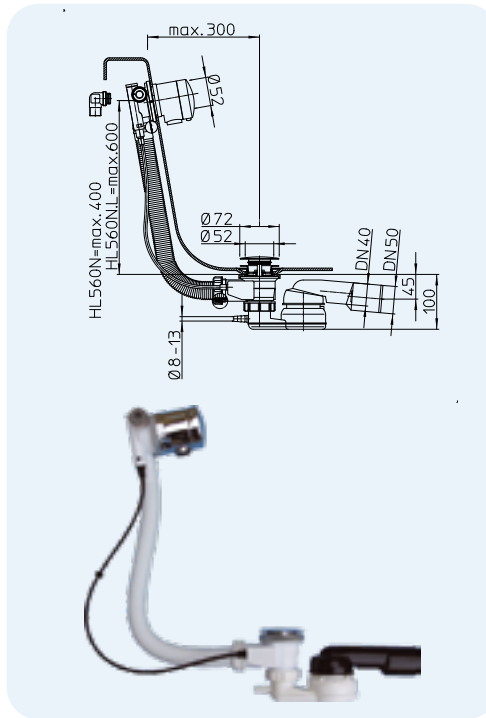

HL-No.	Dimension	Length of the bowden cable	Weight	EAN	Piece/package
560N	DN40/50	60 cm	2340 g	+012428	1
560N.L	DN40/50	80 cm	2345 g	+012503	1

HL51 Bath tub waste and overflow set with chain and plug
Data

Capacity	0,92 l/s
Material	PP
Connection dimension	6/4"
Outlet dimension	vertical 6/4" male thread
Standard	EN 274
Recommended for	also for shower trays and degraded tubs

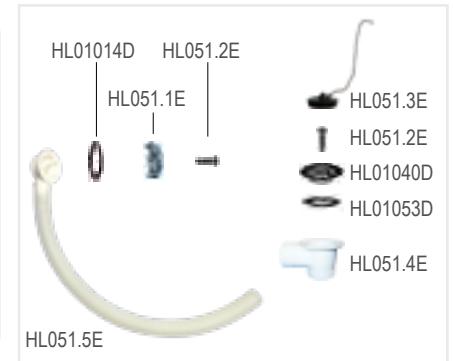
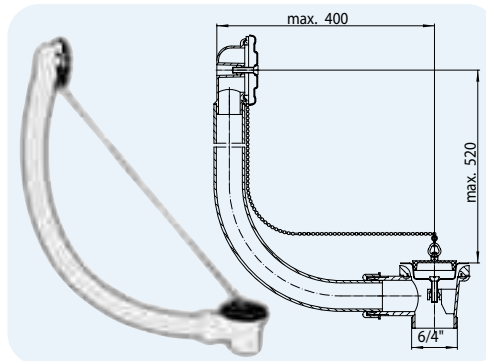

HL-No.	Dimension	Weight	EAN	Piece/package
51	6/4"	290 g	+300518	1

HL500 Bath tub siphon with ball-joint

Data

Capacity	0,83 l/s
Material	PP, outlet pluggable and weldable
Connection dimension	6/4"
Outlet dimension	DN40/50, adjustable in length, horizontal . Ball joint:280° rotatable, 10° inclinable
Standard	EN274
Height of seal water	50 mm
Additional information	Additional connection of e.g. leakage tubes Ø 8 - 13 mm

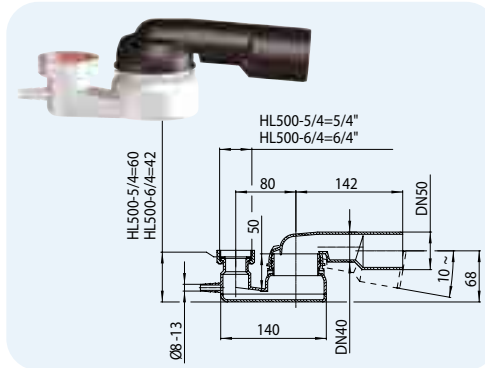

HL-No.	Dimension	Thread	Weight	EAN	Piece/package
500-5/4	DN40/50 x 5/4"	5/4"	90 g	+350056	10
500-6/4	DN40/50 x 6/4"	6/4"	90 g	+350063	10

HL500N Bath tub siphon

Data

Capacity	0,52 l/s
Material	PE: pluggable and weldable
Connection dimension	500N-5/4: Thread 5/4" 500N-6/4: Thread 6/4"
Outlet dimension	DN40/50 adjustable in length, horizontal
Standard	EN274
Height of seal water	50 mm
Additional information	without ball-joint

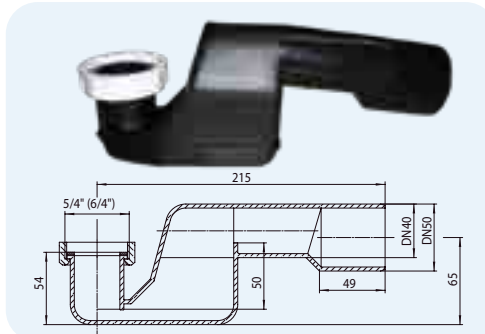

HL-No.	Dimension	Weight	EAN	Piece/package
500N-5/4	DN40/50 x 5/4"	80 g	+350155	10
500N-6/4	DN40/50 x 6/4"	80 g	+350162	10

HL16 Elbow connector

Data

Material	PP
Connection dimension	Thread 6/4"
Outlet dimension	horizontal, DN40
Standard	EN 274

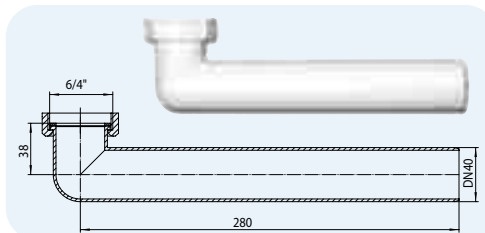

HL-No.	Dimension	Weight	EAN	Piece/package
16	DN40 x 6/4"	80 g	+300167	1



SIPHONS ABLÄUFE



DN50

6-24

193

83

54



HL Siphons

4. Shower trays

4



53

HL Siphons for shower trays

Basic information about design and installation

Basically HL supplies siphons for all usual shower trays, which are according to the standards. To select the right product, please notice the following criteria:

▲ Hole diameter of the shower tray

The European standard HL 274 differs between shower trays with hole diameters Ø 52 mm or Ø 62 mm and Ø 90 mm. HL-shower tray siphons fit to designs, which are according to the European standard (conus, thickness...). To get the perfect tightness, one should take care to use products of high quality of the shower tray.

▲ Capacity

All mentioned drain capacities of shower trays are values, which are tested under standard parameters. Trays with hole diameter Ø 52 mm and Ø 62 mm are tested with 120mm water height, trays with diameter Ø 90 mm only with 15mm, as more and more very flat shower trays are used because of the low entry level.

Of course the water coming from the shower should not be more than the capacity of the drain. We recommend to calculate with a certain cushion.

▲ Maintenance and cleaning

To avoid the deinstallation of the siphon, every time the outlet is plugged, our traps are designed with either removable traps or hair catchers. With smaller hole diameters one should still plan an inspection door. At flat shower trays with hole diameter Ø 90 mm one do not need this. Therefore the siphon itself should be provided with an access to the waste pipe, when it is plugged. ATTENTION: Avoid cleaning with compressed air, as the connection parts in the siphon or in the drain pipe may be splitted.

▲ Convenient in installation

HL offers it's shower tray siphons with rotatable ball-joints, which allow a very quick and also stressless installation.

▲ Flat shower trays

Flat shower trays may be installed directly on the screed with a rest barrier of max. 2cm - and this still counts - acc. to ÖNORM B 3407- as „barriere-free“ installation and therefore as disabled-accessible. The mounting on the screed is cost and time saving - no extra

formworks have to be done on the building site. Beside of that, the waterproofing may be applied on one surface and is not interrupted by hollows or penetrations. With a conventional shower tray siphon (e.g. HL520F) this kind of installation is not possible - there is no way to connect the waterproofing to the siphon. Exactly for that reason HL570 FlexBox - as a complete system solution - was designed. Detailed information please see „product data“.

Relevant standards/directives

EN 274 Drains and siphons for sanitary equipement

HL Siphons for shower trays – Products – Overview

Siphons



Product	HL514	HL514/SN	HL520F
Description	Shower tray siphon with plug	Shower tray siphon with stainless steel cover	Shower tray siphon with ball joint and stainless steel cover
Function	For siphoning shower trays with tray hole Ø 52 mm	For siphoning shower trays with tray hole Ø 52 mm, flat	For siphoning shower trays with tray hole 90mm, high capacity

Siphons



Product	HL511N	HL521	HL570
Description	Shower tray siphon with ball joint and stainless steel cover	Flat shower tray siphon with ball joint and stainless steel cover	Shower tray siphon for flat shower trays
Function	For siphoning shower trays with tray hole 90mm	For siphoning shower trays with tray hole 90mm, flat version	System solution for the waterproof connection between waterproofing and drain body.

HL Shower Trays - Installation of HL570



1. Measure distances of the middle of the tray slope

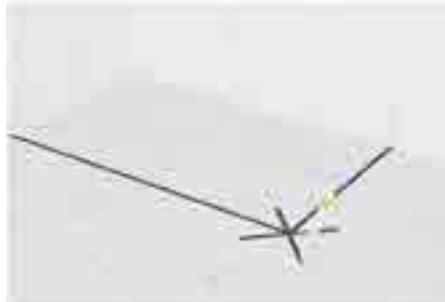

2. Transfer measures to the concrete ceiling



3. Mark positions for the drilling holes



4. Drill holes



5. Fix drain body with fixing angles



6. Connect drain body with the drain pipe, adjust the slope of the pipe



7. Fill in screed



8. Cut salient nozzle



9. Insert sealing kit (flex-element) in the drain body



10. Apply moisture proofing compound



11. Maximum deviation: 4cm (plus/minus 2cm from the center)



12. Insert the waste valve and screw it together with the counter nut. The gasket has to be tight on the bottom of the tray

HL Shower Trays - Installation of HL570



13. Set tray on the screed



14. Pull bottom ring of the counter nut to the waste valve



15. Connect flex-element with bottom ring of the counter nut

- Dont forget: Leak test
- After leak test insert lot cover again



16. Apply tile glue



17. Set tiles



18. Sectional drawing of the floor



19. Remove lot cover, insert siphon and cover



20. Good job!



HL Siphons for shower trays – Products – Data

HL570 Complete installation-kit for flat shower trays, incl. stainless steel cover

HL570.0 Complete installation-kit for flat shower trays, without cover

HL570.0-Plan Complete installation-kit for flat shower trays, but with flattened screw valve

Data

Capacity	0,5 l/s
Material	PP/TPE/Stainless steel
Constr. height	80 - 200 mm (250 mm)
Visible parts	HL570: Stainless steel cover Ø 113 mm HL570.0: Without cover
Connection	Tray hole Ø 90 mm
Outlet dimension	DN40/50 horizontal
Siphon	Removable 2-part siphon
Standard	EN 274 ÖNORM B 3407
Height of seal water	50 mm
Including	Drain body with lot cover, 3 fixing angles and drilling template; Flex-element (blue), cover, waste valve with lot cover/mounting wrench and 2-part siphon
Additional information	The drain body is set in the screed and connected information to the moisture proofing compound. Waterproof connection between shower tray and drain body by snapping on the flex-element. Horizontal and vertical deviations of 4cm (plus/minus 2cm from the center) are possible. Soundproofing tested Test certificate: www.hl.at Compatibility list for matching shower trays at www.hl.at
Recommended for	Flat shower trays made of steel enamel, stone, acryl, mineral casting... with hole Ø 90 mm
Accessories	Screw valve HL0570.1E-Plan for shower trays that do NOT comply with the standard specifications for the geometry of the drain opening according to EN251.

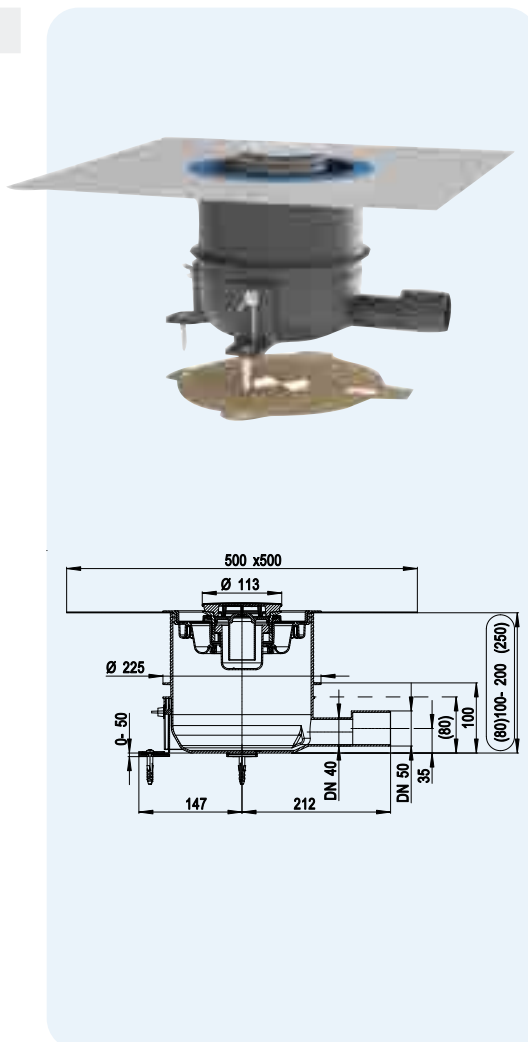

HL-No.	Dimension	Cover	Weight	EAN	Piece/package
570	DN40/50	Stainless steel V2A	1329 g	+049998	1
570.0	DN40/50	-	1240 g	+050017	1
570.0-Plan	DN40/50	-	1300 g	+051823	1



HL0570.1E-Plan



HL520F Shower tray siphon DN40/50 for tray hole 90 mm

Data

Capacity	0,60 l/s
Material	PP/PE
Visible parts	Cover platte Ø 112 mm, polished stainless steel
Connection	Tray hole Ø 90 mm
Outlet dimension	Convertible from horizontal to vertical, DN40/50, adjustable in lenght
Stench trap	Removable rubber membrane
Standard	EN274
Height of seal water	50 mm
Including	Hair catcher, lot cover
Additional information	Installation height 74 mm!

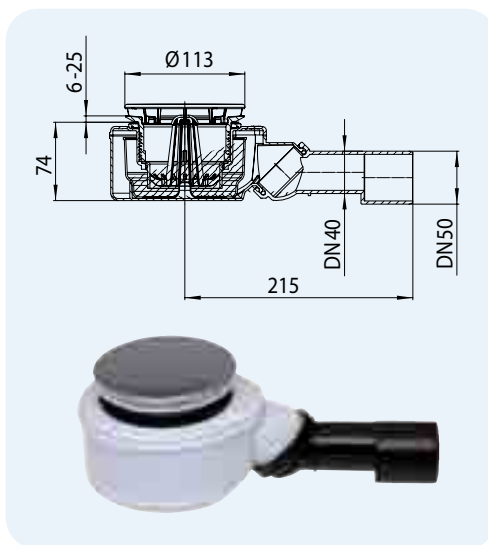

HL-No.	Dimension	Cover plate	Capacity	Installation height	Weight	EAN	Piece/package
520F	DN40/50	Stainless steel	0,6 l/s	74 mm	530 g	+037452	1
520F.0	DN40/50	-	0,6 l/s	74 mm	390 g	+037476	1
520	DN50	Stainless steel	0,9 l/s	83 mm	530 g	+031122	1

HL522... Coloured stainless steel covers, fitting to HL520-, HL570- and HL522-series

Data

Ø	112 mm
Material	HL522.1: Stainless steel polished HL522.11: Gold-plated brass HL522.2: Solid brass HL522.3: Stainless steel, White coloured



HL-No.	Colour	Weight	EAN	Piece/package
522.1	Stainless steel	139 g	+008902	1
522.11	Gold-plated brass	139 g	+008926	1
522.2	Solid brass	139 g	+008940	1
522.3	White	139 g	+ 008964	1

HL521 Flat shower tray siphon DN40 with ball joint for tray hole 90mm

Data

Capacity	0,42 l/s
Material	PP/PE
Visible parts	Stainless steel
Connection dimension	For tray hole Ø 90 mm
Outlet dimension	with adjustable ball joint 0-15° DN40
Odor trap	Removable
Standard	EN274
Height of seal water	30 mm
Additional information	Height over all 60 mm!

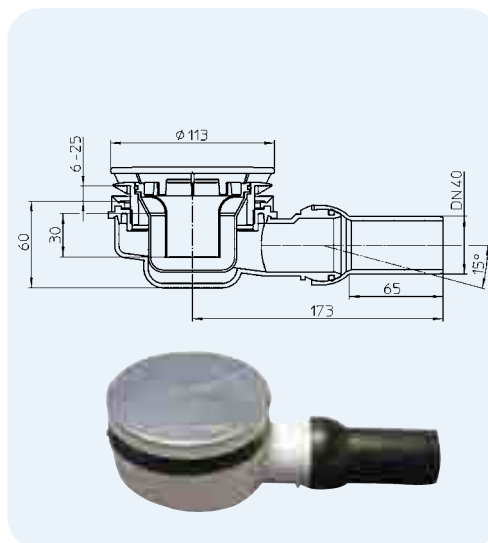

HL-No.	Dimension	Weight	EAN
HL521	DN40	410 g	+033263

HL511N Vertical shower tray siphon DN50 for tray hole Ø 90 mm

Data

Capacity	0,53 l/s
Material	PP
Grate	Cover plate Ø 113 mm, polished stainless steel
Connection dimension	For tray hole Ø 90 mm
Outlet dimension	Vertical
Trap	Removable
Standard	EN274
Height of seal water	50 mm
Including	Lot cover
Additional information	Vertical shower trap siphon

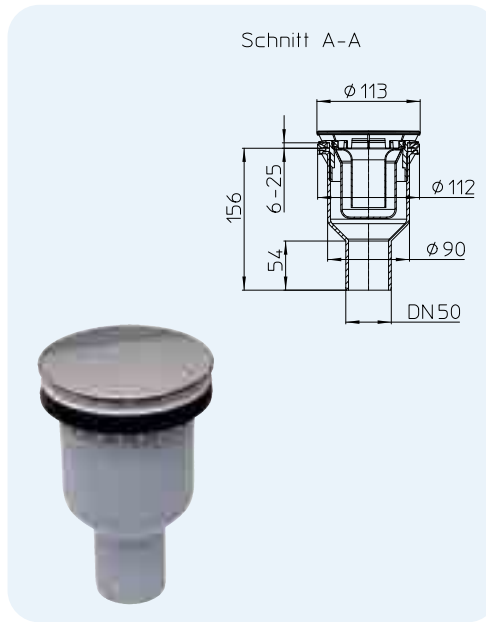

HL-No.	Dimension	Cover plate	Weight	EAN	Piece/package
HL511N	DN50	Stainless steel	300 g	+034895	1

HL514/SN... Shower tray siphon 6/4" with ball-joint, (cover and tube connector)

Data

Capacity	HL514/SN, HL514/SN-80, HL514/SNV: 0,48 l/s HL514/SN.0, HL514/SNV.0: 0,48 l/s
Material	PP outlet pluggable and weldable
Visible parts	HL514/SN: Stainless steel cover Ø 86 mm, HL514/SN.0, HL514/SNV.0: Without cover
Connection dimension	HL514/SN, HL514/SNV, HL514/SN.0, HL514/SNV.0: for tray holes Ø 52 mm HL514/SN-80: Valve Ø 80 mm for tray holes Ø 62 mm
Outlet dimension	horizontal, ball-joint: 280° rotatable, 10° inclinable DN 40/50 adjustable in length
Hose nozzle	HL514/SNV, HL514/SNV.0: Tube connector 8 - 13 mm e.g. for leakage tubes or steam showers.
Standard	EN274
Height of seal water	50 mm

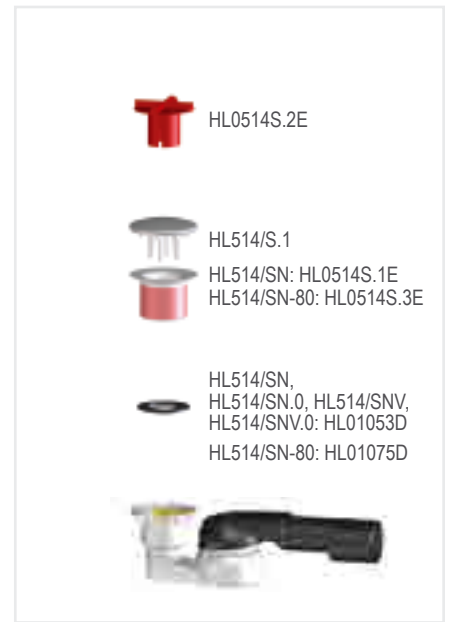
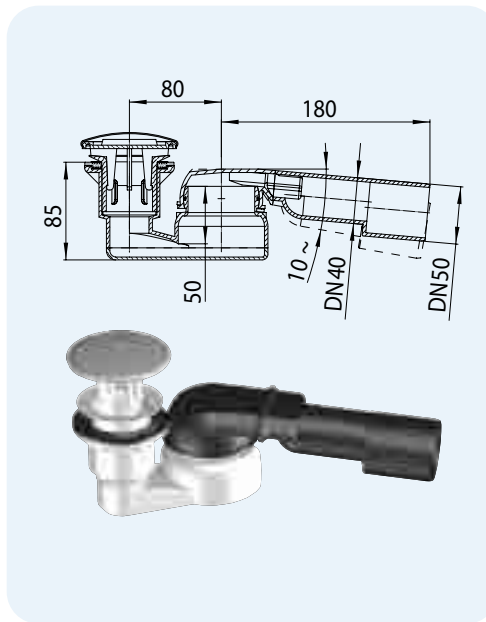

HL-No.	Dimension	Cover	Hose nozzle	Weight	EAN	Piece/package
514/SN	DN40/50	Stainless steel	-	330 g	+004751	10
514/SN-80	DN40/50	Stainless steel	-	335 g	+004775	1
514/SN.0	DN40/50	-	-	235 g	+004799	10
514/SNV	DN40/50	Stainless steel	8 - 13 mm	330 g	+004911	10
514/SNV.0	DN40/50	-	8 - 13 mm	235 g	+010776	10

HL514/S... Stainless steel covers in different colours, fitting to HL514/SN and HL514/SNV

Data

Ø	86 mm
Material	HL514/S.1: Stainless steel HL514/S.11: Gold-plated brass HL514/S.2: Solid brass HL514/S.3: Stainless steel, White coloured



HL-No.	Colour	Weight	EAN	Piece/package
514/S.1	Stainless steel	95 g	+405138	1
514/S.11	Gold-plated brass	95 g	+425136	1
514/S.2	Solid brass	95 g	+425143	1
514/S.3	White	95 g	+ 525140	1

HL514 Shower tray siphon 6/4" with ball-joint and plug

Data

Capacity	0,58 l/s
Material	PP, outlet pluggable and weldable
Visible parts	Stainless steel
Connection dimension	HL514: Valve 6/4" for hole Ø 52 mm, HL514-80: Valve Ø 80 mm for hole Ø 62 mm
Outlet dimension	horizontal, ball-joint: 280° rotatable, 10° inclinable HL514, HL514-80: DN 40/50 cuttable in length
Hose nozzle	-
Standard	EN274
Height of seal water	50 mm
Including	Plug and hair catcher 6/4"

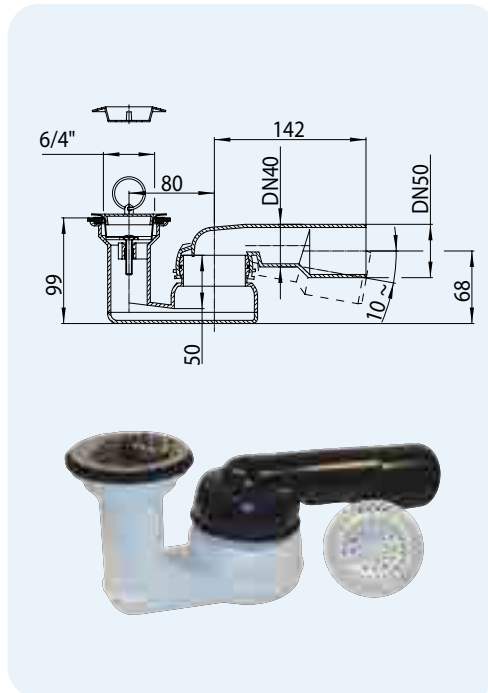

HL-No.	Dimension	Weight	EAN	Piece/package
514	DN40/50	275 g	+305148	10
514-80	DN40/50	260 g	+514809	1

HL513/S Vertical shower trap connector 6/4"

Data

Capacity	0,75 l/s
Material	PP
Visible parts	Stainless steel 86mm
Connection dimension	Outlet 6/4" for hole 52mm
Outlet dimension	vertical DN40
Standard	EN274
Additional info	without trap

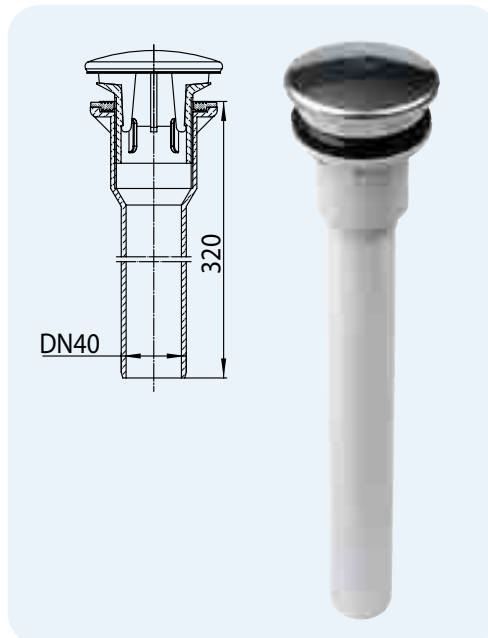

HL-No.	Dimension	Cover	Weight	EAN	Piece/package
513/S	DN40	Stainless steel	420 g	+513000	1
513/S.0	DN40	-	325 g	+513017	1

HL Siphons for shower trays – Products – Accessories

HL16.1 Elbow connector for shower trays

Data

Material	PP
Connection dimension	Waste outlet 6/4"
Outlet	horizontal, DN 40/50 adjustable in length

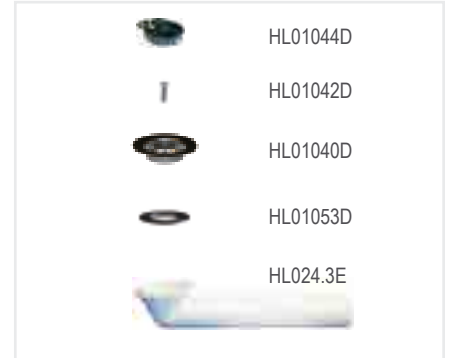
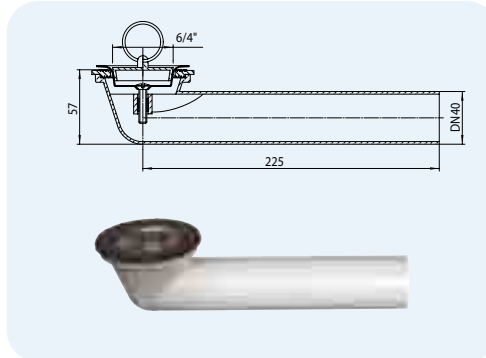

HL-No.	Dimension	Weight	EAN	Piece/package
16.1	DN40	150 g	+301614	1

HL515, HL515/S, HL517 Acrylic glass immersion tube

Data

Material	Polycarbonate
Dimension	HL515, HL515/S: h = 100 mm HL517: h = 105 mm
Additional information	HL515: fits to HL514 and HL80.2(H) HL515/S: fits to HL514/SN(V) and HL513/S HL517: fits to HL520- and HL522-series All immersion tubes are available in different length on request



HL-No.	Dimension	Weight	EAN	Piece/package
515	h = 100 mm	42 g	+305155	1
515/S	h = 100 mm	42 g	+315154	1
517	h = 105 mm	87 g	+008810	1

HL525, HL526 Hair catcher

Data

Material	PE
Dimension	HL525: 5/4" HL526: 6/4"

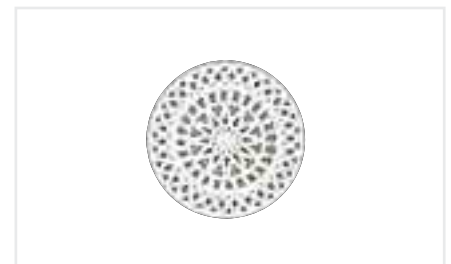
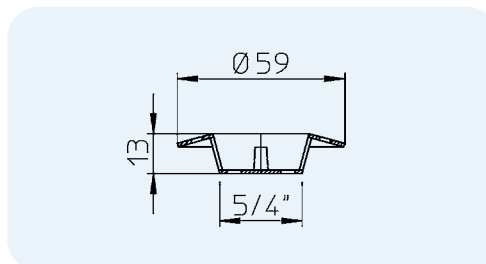

HL-No.	Dimension	Weight	EAN	Piece/package
525	5/4"	12 g	+305254	1
526	6/4"	12 g	+305261	1



SIPHONS ABLÄUFE

503 x 303
380 x 180
304 x 104



33

71,5

108

133



HL System solutions

5. Barrier-free showers

5

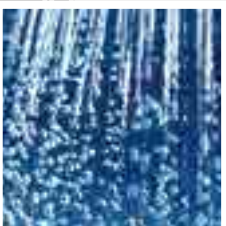

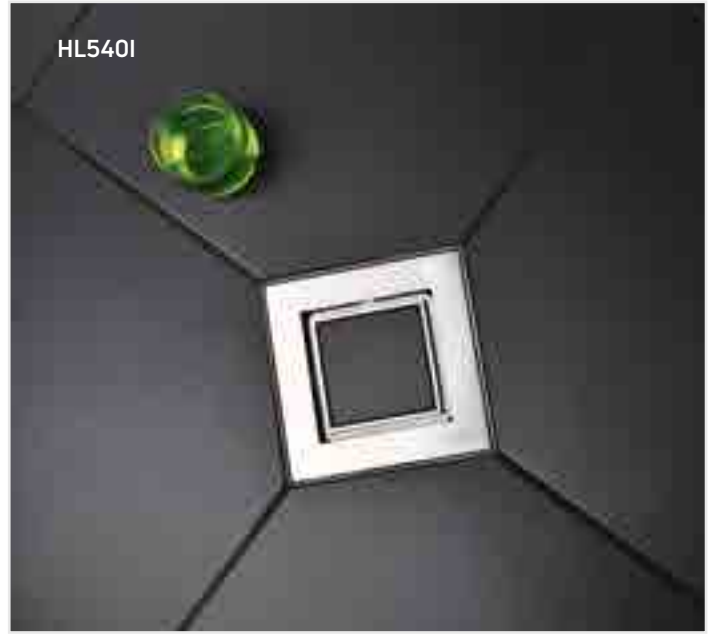

HL System solutions for barrier-free showers

Basic information for planning and execution

Barrier-free showers nowadays are very popular to end-users. The advantages are obvious: Real and optical gain of space, individual design of the shower area, and now also a wide range of barrier-free shower solutions in every price segment. In case of installation of barrier-free showers, it can be observed, that the practice is far away from the theory, whatsoever. There are many interfaces, where the instalment can go wrong and therefore the bathroom users expectations are not fulfilled; because of wrong consultation, because of a lack of coordination between construction company, installer, tiler...

In order to prevent this failures it is recommended to draw attention to certain aspects, such as following:

▲ Installation height

Especially in case of bathroom renovation, the installer has the problem of low floor heights - this leads to low drainage systems. Please do not forget, that for all tiled shower spaces a slope of minimum 2% is needed and has to be added to the drain height, when calculating!

▲ Capacity

Calculation of the required minimum drain capacity: Capacity of the shower fitting + 20%! The test procedure for the determination of the drain capacity is described in EN 1253-2; in this standard the nominal capacity is valid with a water height of 20mm above the grate or cover of the drain.

▲ Connection to the waterproofing

Tiled showers are most endangered areas, concerning the penetration of moisture into the floor (and wall) construction (according ÖNORM B 2207 danger class W4). Since tiles and tile glue are not regarded as a permanent sealing, a waterproofing has to be applied below the tiles. Most endangered spot is the transition from drain to the sealing compound. Therefore high quality drains are equipped with flanges, which care for the tight sealing in this area. Also these drains should be able, to drain off leakage water, which is staying below the tiles (secondary water drainage).

▲ Selection of the drain system:

Point drainage



▲ Advantages of point drainage:

- o Easy and long term experienced installation
- o Low price
- o Less construction height, as the drain position is mostly in the middle and not at the end of the shower area
- o Individual choice of the drain position according to the tile pattern, perfect for diagonal tiling

Linear drainage



▲ Advantages of linear drainage:

- o Easy preparation of the screed slope (only in one direction)
- o Perfect for large tiles
- o Installation close to the wall avoids the overflow of water into the rest of the bathroom
- o High end design

▲ Stench trap

According to standard EN 12056-2 odor traps must be installed inside of the buildings. Every odor trap has to have water seal of at least 5 cm height in order to prevent odor rising into the building. In case of vacuum in the drainage system, these 5 cm water prevent the trap from being sucked out by the vacuum. In case of lower floor heights (renovation) the sealing height in the trap could be less than 5 cm, if the trap is equipped with an additional mechanical odor barrier. For this case HL shower drain systems are equipped with the proven Primusblue system. The Primusblue is a combined trap with sealing water and a mechanical odor barrier that provides absolute odor-tightness and even more protection against unpleasant odors from the sewer. With a tightness at overpressure up to +800 Pascal and at negative pressure down to -400 Pascal, Primusblue offers more safety compared to conventional water odor seals with 50 mm sealing water. Another benefit is the function of backflow tightness down to a pressure of 0.5 mWs. The backflow of wastewater in the case of awkwardly laid drainage pipes (e.g. from a bathtub or swimming pool backwash) is effectively prevented.

▲ Coordination at the building site

Usually three different kind of craftsmen work on the completion of a barrier-free shower: Screed layer, plumber and tiler. Therefore a good cross-over communication between these craftsmen is needed. For this purpose we recommend, to establish a central planning authority (planner, architect, ...).

▲ Design

HL is offering different kinds of covers in different colours. Therefore the final decision has to be taken in accordance with the end-user of the bathroom.

HL Barrier-free showers – Sectional drawings

HL053S
Shower channel



HL053WS
„Wall“
Shower channel



HL531Prblue shower
channel Primus blue



HL Barrier-free showers – Sectional drawings

HL540/541
„Primus Drain /
Primus blue”
Shower drain



HL542Prblue
„Primus Drain /
Primus blue”
Shower drain

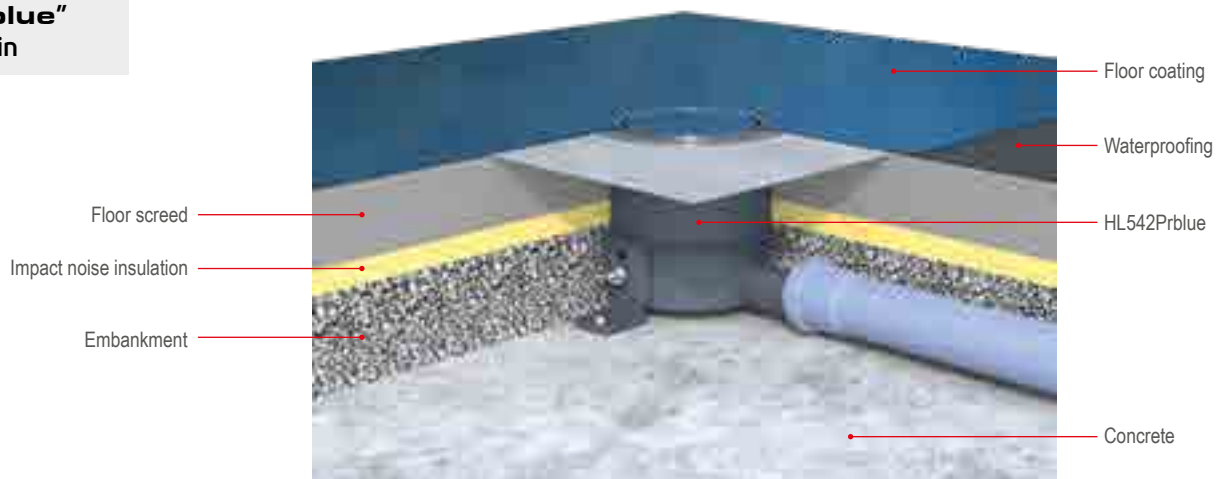

HL310KH-3020
„Primus Drain /
Primus blue”
Shower drain



Primus **blue** trap - function



„Primus **blue**“ - the new HL hybrid trap for shower and floor drains - works mechanic and hydraulic. It protects from smell, no matter if there is under pressure, over pressure or if the water inside is evaporated.



When the water from the shower runs through the trap, the valve disc opens.



When the valve disc is opened, the water may pass the trap as usual.

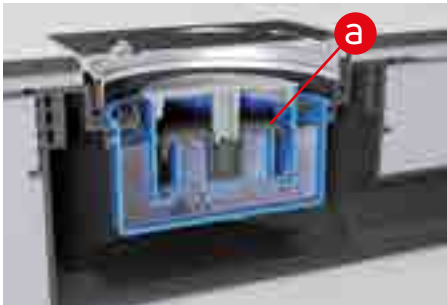

if the water inflow is stopped, the valve disc closes, the water stays inside the trap.

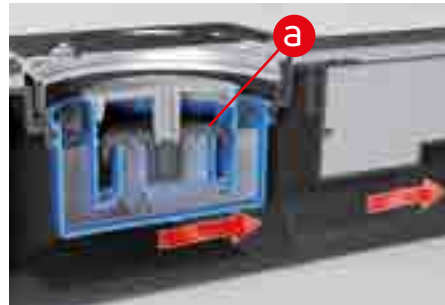

Underpressure from the sewer: The weight of the valve disc together with the water inside the trap protects from getting sucked out.

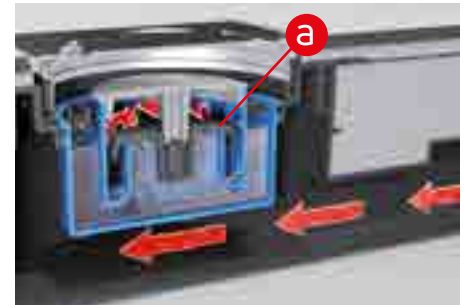

Overpressure in the sewer: The valve disc is pressed against the valve seat, so no smell may get out. A further advantage: the trap is save against back flow.

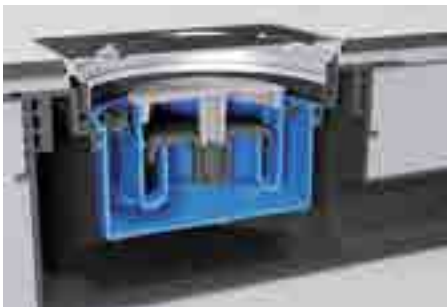

Should the water inside the trap be evaporated, e.g. caused by a floor heating, the mechanic trap protects from bad smell

Primus blue



HL Barrier-free showers - Installation manual HL540/541



1. Define outlet position, set the stencil in direction to the outlet pipe and mark the holes for the drilling.



2. Drill holes



3. Fix the drain body with fixing angles on the floor and connect to the pipe.



4. Adjust the decline of the pipe by using the angles and level the drain body.



5. Insert floor screed and create a slope to the drain by minimum 2%.



6. After the floor screed is dry, cut the salient nozzle with a saw (or cutting disc).



7. Insert the sealing kit, turn the protection cover and insert it again.



8. Apply waterproofing in the whole shower area and on (and under) the sealing kit, seal the edges with sealing tapes.



9. Insert the extension, if necessary, cut the extension.



10. Adjust the extension by turning to the tile layout (360° turnable), lay the tiles.



11. Remove the protection cover and insert the grate.



12. Ready

HL Barrier-free showers - Installation manual HL542Prblue



1. Determine the drain position, place the installation template in the direction of the drain pipe and mark the position for the drill holes.



2. Drill holes and fix the drain body to the concrete ceiling using fixing brackets and screws.



3. Connect the drain body to the drain pipe. Adjust the height and the pipe slope using the fixing brackets, align the drain body horizontally as shown in Fig. 3.



4. Create the floor structure with a slope of minimum 2% in the screed.



5. After the screed has hardened, cut off the remaining pipe flush with the floor using a saw.



6. Insert the waterproofing set into the drain.

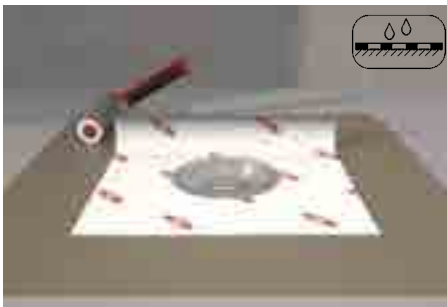

7. Apply waterproofing below and above the sealing set (sandwich method), as well as in the entire shower area. Provide all connection points with sealing tapes.

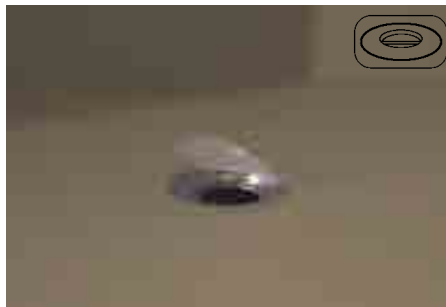

8. Remove protective foil



9. Waterproofing layer connects to the stainless steel flange of the waterproofing set as shown in Fig. 9



10. Completely insert the round stainless steel frame with O-ring into the waterproofing set, height of the frame is 1 mm = coating thickness see Fig. 10.2



11. The round stainless steel frame can also be adjusted to the required coating height with one or in combination with several extension rings. The height is adjusted in 1 mm increments. The adjustment range here is between 1 and 7 mm.

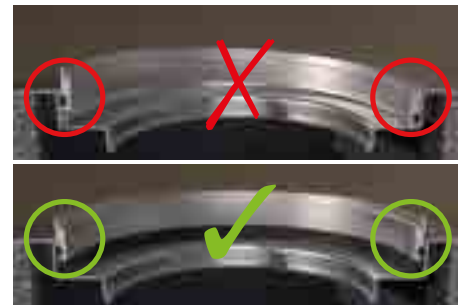

12. Ensure that the round stainless steel ring is correctly positioned.

HL Barrier-free showers - Installation manual HL542Prblue



13. Clean the stainless steel flange and insert the lot cover.



14. Apply the coating according to the manufacturer's instructions.



15. Flush finish of the coating with the round stainless steel frame.

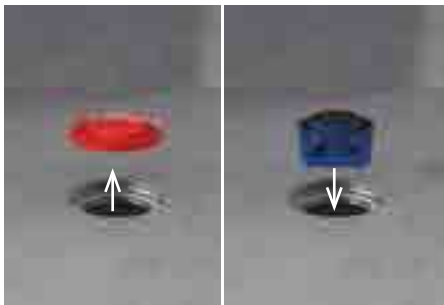

16. Remove lot cover and insert Primusblue odour barrier.

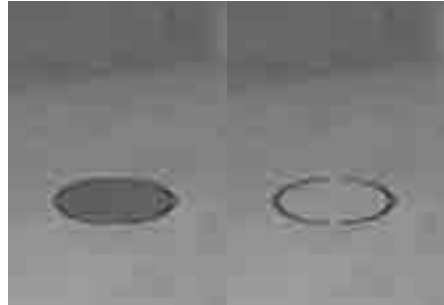

17. The stainless steel combined cover can be inserted either in a stainless steel look or coated.



HL Barrier-free showers – Products – Data

HL50F.0 Shower channel made of stainless steel, installation in the surface, HEIGHT 110 MM!

Data

Capacity	600 – 1300 mm length = 0,8 l/s 1400 – 2100 mm length = 1,4 l/s
Material	Stainless steel 1.4301/PP
Outlet dimension	DN50 with ball-joint
Height	110 mm
Standard	EN 1253
Height of seal water	50 mm
Additional information	removable stretch trap, with 5cm surrounding sand-coated flange for a save connection to the under-tile waterproofing. The frameless design makes it possible, to choose border bars, fitting to the tiles and enables under-tile leakage water, to flow into the trap.
Including	Sound absorbing height adjustable levelling legs, 2 pieces of edge trim jigs, 2 pieces of tiling gauges

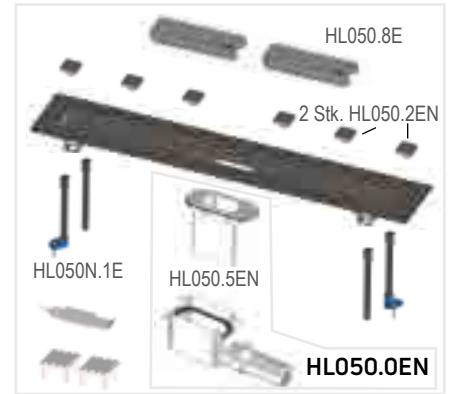
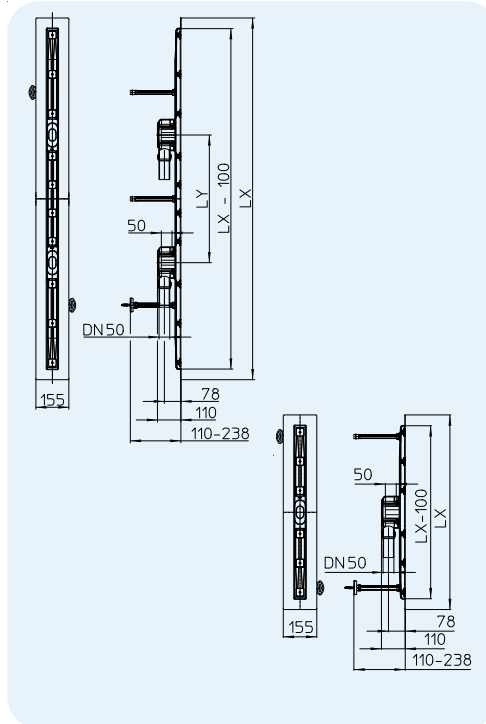

When using ceramic tiles we recommend to produce an individual frame made of tiling profiles.

HL-No.	Material	Dimension	length LX	length LY	Capacity	Weight	EAN	Piece/package
HL50F.0/60	Stainless steel	DN50	600 mm		0,8l/s	2261 g	+024599	1
HL50F.0/70	Stainless steel	DN50	700 mm		0,8l/s	2488 g	+024612	1
HL50F.0/80	Stainless steel	DN50	800 mm		0,8l/s	2729 g	+024636	1
HL50F.0/90	Stainless steel	DN50	900 mm		0,8l/s	2937 g	+024650	1
HL50F.0/90.2	Stainless steel	2 x DN50	900 mm	200 mm	1,4l/s	3194 g	+032433	1
HL50F.0/100	Stainless steel	DN50	1000 mm		0,8l/s	3224 g	+024674	1
HL50F.0/100.2	Stainless steel	2 x DN50	1000 mm	300 mm	1,4l/s	3480 g	+032440	1
HL50F.0/110	Stainless steel	DN50	1100 mm		0,8l/s	3525 g	+024698	1
HL50F.0/110.2	Stainless steel	2 x DN50	1100 mm	300 mm	1,4l/s	3782 g	+032457	1
HL50F.0/120	Stainless steel	DN50	1200 mm		0,8l/s	3760 g	+024711	1
HL50F.0/120.2	Stainless steel	2 x DN50	1200 mm	400 mm	1,4l/s	4017 g	+032464	1
HL50F.0/130	Stainless steel	DN50	1300 mm		0,8l/s	3966 g	+024735	1
HL50F.0/130.2	Stainless steel	2 x DN50	1300 mm	400 mm	1,4l/s	4150 g	+032471	1
HL50F.0/140	Stainless steel	2 x DN50	1400 mm	500 mm	1,4l/s	5840 g	+030545	1
HL50F.0/150	Stainless steel	2 x DN50	1500 mm	500 mm	1,4l/s	6120 g	+030569	1
HL50F.0/160	Stainless steel	2 x DN50	1600 mm	600 mm	1,4l/s	6260 g	+030583	1
HL50F.0/170	Stainless steel	2 x DN50	1700 mm	600 mm	1,4l/s	6600 g	+030606	1
HL50F.0/180	Stainless steel	2 x DN50	1800 mm	700 mm	1,4l/s	6820 g	+030620	1
HL50F.0/190	Stainless steel	2 x DN50	1900 mm	700 mm	1,4l/s	7060 g	+030644	1
HL50F.0/200	Stainless steel	2 x DN50	2000 mm	800 mm	1,4l/s	7240 g	+030668	1
HL50F.0/210	Stainless steel	2 x DN50	2100 mm	800 mm	1,4l/s	7560 g	+030682	1

HL50FF.0 Shower channel made of stainless steel, installation in the surface (flat version), HEIGHT 90 MM!
Data

Capacity	600 – 1300 mm length = 0,7 l/s 1400 – 2100 mm length = 1,2 l/s
Material	Stainless steel 1.4301/PP
Outlet dimension	DN50 with ball-joint
Height	90 mm
Height of seal water	30 mm
Additional information	removable stench trap, with 5cm surrounding sand-coated flange for a save connection to the under-tile waterproofing. The frameless design makes it possible, to choose border bars, fitting to the tiles and enables under-tile leakage water, to flow into the trap.
Including	Sound absorbing height adjustable levelling legs, 2 pieces of edge trim jigs, 2 pieces of tiling gauges

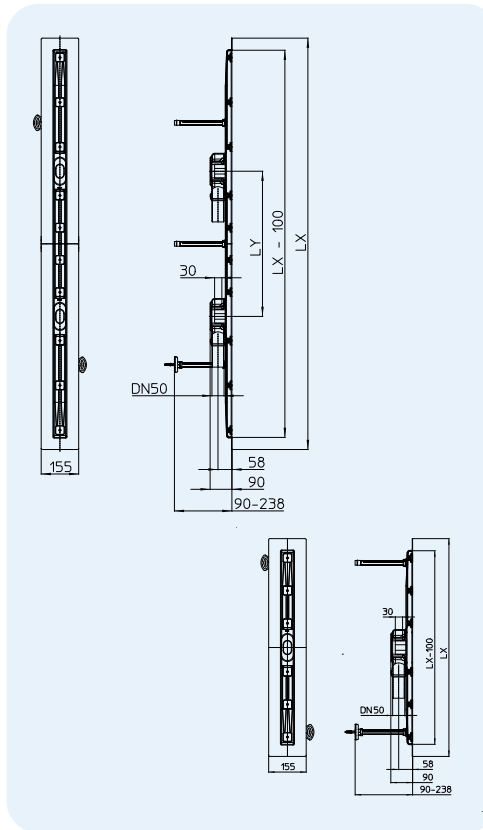

When using ceramic tiles we recommend to produce an individual frame made of tiling profiles.

HL-No.	Material	Dimension	length LX	length LY	Capacity	Weight	EAN	Piece/package
HL50FF.0/60	Stainless steel	DN50	600 mm		0,7l/s	2261 g	+029761	1
HL50FF.0/70	Stainless steel	DN50	700 mm		0,7l/s	2488 g	+029778	1
HL50FF.0/80	Stainless steel	DN50	800 mm		0,7l/s	2729 g	+029785	1
HL50FF.0/90	Stainless steel	DN50	900 mm		0,7l/s	2937 g	+029792	1
HL50FF.0/90.2	Stainless steel	2 x DN50	900 mm	200 mm	1,2l/s	3135 g	+035717	1
HL50FF.0/100	Stainless steel	DN50	1000 mm		0,7l/s	3224 g	+024834	1
HL50FF.0/100.2	Stainless steel	2 x DN50	1000 mm	300 mm	1,2l/s	3422 g	+035724	1
HL50FF.0/110	Stainless steel	DN50	1100 mm		0,7l/s	3525 g	+024858	1
HL50FF.0/110.2	Stainless steel	2 x DN50	1100 mm	300 mm	1,2l/s	3723 g	+035731	1
HL50FF.0/120	Stainless steel	DN50	1200 mm		0,7l/s	3760 g	+024872	1
HL50FF.0/120.2	Stainless steel	2 x DN50	1200 mm	400 mm	1,2l/s	3958 g	+035748	1
HL50FF.0/130	Stainless steel	DN50	1300 mm		0,7l/s	3966 g	+024896	1
HL50FF.0/130.2	Stainless steel	2 x DN50	1300 mm	400 mm	1,2l/s	4164 g	+035755	1
HL50FF.0/140	Stainless steel	2 x DN50	1400 mm	500 mm	1,2l/s	5840 g	+033362	1
HL50FF.0/150	Stainless steel	2 x DN50	1500 mm	500 mm	1,2l/s	6120 g	+033379	1
HL50FF.0/160	Stainless steel	2 x DN50	1600 mm	600 mm	1,2l/s	6260 g	+033386	1
HL50FF.0/170	Stainless steel	2 x DN50	1700 mm	600 mm	1,2l/s	6600 g	+033393	1
HL50FF.0/180	Stainless steel	2 x DN50	1800 mm	700 mm	1,2l/s	6820 g	+033409	1
HL50FF.0/190	Stainless steel	2 x DN50	1900 mm	700 mm	1,2l/s	7060 g	+033416	1
HL50FF.0/200	Stainless steel	2 x DN50	2000 mm	800 mm	1,2l/s	7240 g	+033423	1
HL50FF.0/210	Stainless steel	2 x DN50	2100 mm	800 mm	1,2l/s	7560 g	+033430	1

HL50FU.0 Shower channel made of stainless steel, installation in the surface (extra flat), HEIGHT 68 MM!
Data

Capacity	600 - 1300 mm length = 0,46 l/s 1400 - 2100 mm length = 0,82 l/s
Material	Stainless steel 1.4301/PP
Outlet dimension	DN50
Height	68 mm
Standard	EN 1253
Height of seal water	24 mm
Additional information	Removable stench trap, with 5 cm surrounding sand coated flange for a save connection to the under-tile waterproofing. The frameless design makes it possible, to choose border bars, fitting to the tiles and enables under-tile leakage water, to flow into the trap.
Including	Sound absorbing height adjustable levelling legs, 2 pieces of edge trim jigs, 2 pieces of tiling gauges.

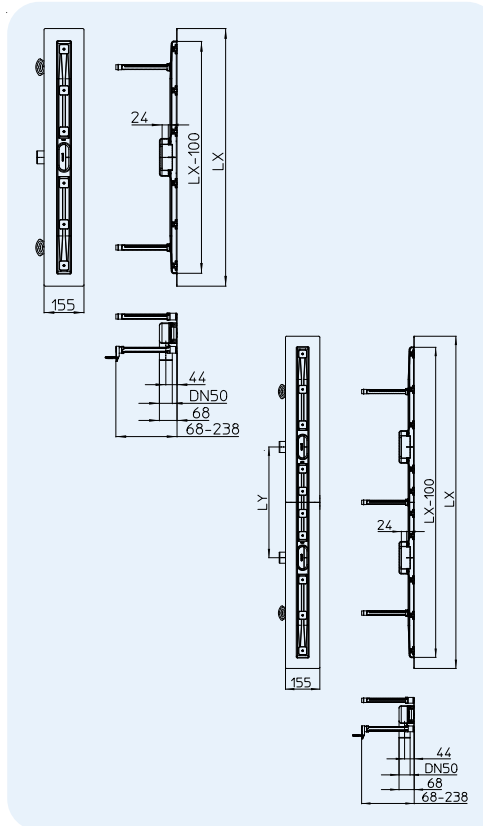

When using ceramic tiles we recommend to produce an individual frame made of tiling profiles.

HL-No.	Material	Dimension	length LX	length LY	Capacity	Weight	EAN	Piece/package
HL50FU.0/60	Stainless steel	DN50	600 mm		0,46 l/s	2261 g	+033904	1
HL50FU.0/70	Stainless steel	DN50	700 mm		0,46 l/s	2488 g	+033911	1
HL50FU.0/80	Stainless steel	DN50	800 mm		0,46 l/s	2729 g	+033928	1
HL50FU.0/90	Stainless steel	DN50	900 mm		0,46 l/s	2937 g	+033935	1
HL50FU.0/90.2	Stainless steel	2 x DN50	900 mm	200 mm	0,82 l/s	3194 g	+035762	1
HL50FU.0/100	Stainless steel	DN50	1000 mm		0,46 l/s	3224 g	+033942	1
HL50FU.0/100.2	Stainless steel	2 x DN50	1000 mm	300 mm	0,82 l/s	3481 g	+035779	1
HL50FU.0/110	Stainless steel	DN50	1100 mm		0,46 l/s	3525 g	+033959	1
HL50FU.0/110.2	Stainless steel	2 x DN50	1100 mm	300 mm	0,82 l/s	3782 g	+035786	1
HL50FU.0/120	Stainless steel	DN50	1200 mm		0,46 l/s	3760 g	+033980	1
HL50FU.0/120.2	Stainless steel	2 x DN50	1200 mm	400 mm	0,82 l/s	4017 g	+035793	1
HL50FU.0/130	Stainless steel	DN50	1300 mm		0,46 l/s	3966 g	+033997	1
HL50FU.0/130.2	Stainless steel	2 x DN50	1300 mm	400 mm	0,82 l/s	4140 g	+035809	1
HL50FU.0/140	Stainless steel	2 x DN50	1400 mm	500 mm	0,82 l/s	5840 g	+034000	1
HL50FU.0/150	Stainless steel	2 x DN50	1500 mm	500 mm	0,82 l/s	6120 g	+034017	1
HL50FU.0/160	Stainless steel	2 x DN50	1600 mm	600 mm	0,82 l/s	6260 g	+034024	1
HL50FU.0/170	Stainless steel	2 x DN50	1700 mm	600 mm	0,82 l/s	6600 g	+034031	1
HL50FU.0/180	Stainless steel	2 x DN50	1800 mm	700 mm	0,82 l/s	6820 g	+034048	1
HL50FU.0/190	Stainless steel	2 x DN50	1900 mm	700 mm	0,82 l/s	7060 g	+034055	1
HL50FU.0/200	Stainless steel	2 x DN50	2000 mm	800 mm	0,82 l/s	7240 g	+034062	1
HL50FU.0/210	Stainless steel	2 x DN50	2100 mm	800 mm	0,82 l/s	7560 g	+034079	1

HL50W.0 Shower channel made of stainless steel, installation wall-side, HEIGHT 110 MM!
Data

Capacity	600 – 1300 mm length = 0,8 l/s 1400 – 2100 mm length = 1,4 l/s
Material	Stainless steel 1.4301/PP
Outlet dimension	DN50 with ball-joint
Height	110 mm
Standard	EN 1253
Height of seal water	50 mm
Additional information	removable stench trap, with 5cm surrounding sand-coated flange for a save connection to the under-tile waterproofing. The frameless design makes it possible, to choose border bars, fitting to the tiles and enables under-tile leakage water, to flow into the trap.
Including	Sound absorbing height adjustable levelling legs, 2 pieces of edge trim jigs, 2 pieces of tiling gauges

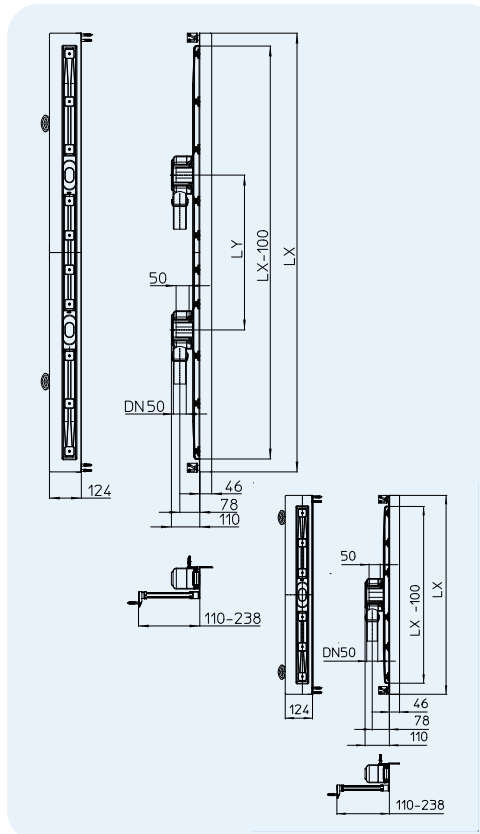

When using ceramic tiles we recommend to produce an individual frame made of tiling profiles.

HL-No.	Material	Dimension	length LX	length LY	Capacity	Weight	EAN	Piece/ package
HL50W.0/60	Stainless steel	DN50	600 mm		0,8l/s	2409 g	+024759	1
HL50W.0/70	Stainless steel	DN50	700 mm		0,8l/s	2655 g	+024773	1
HL50W.0/80	Stainless steel	DN50	800 mm		0,8l/s	2965 g	+024797	1
HL50W.0/90	Stainless steel	DN50	900 mm		0,8l/s	3248 g	+024810	1
HL50W.0/90.2	Stainless steel	2 x DN50	900 mm	200 mm	1,4 l/s		+032495	1
HL50W.0/100	Stainless steel	DN50	1000 mm		0,8l/s	3462 g	+024834	1
HL50W.0/100.2	Stainless steel	2 x DN50	1000 mm	300 mm	1,4 l/s		+032488	1
HL50W.0/110	Stainless steel	DN50	1100 mm		0,8l/s	3769 g	+024858	1
HL50W.0/110.2	Stainless steel	2 x DN50	1100 mm	300 mm	1,4 l/s		+032501	1
HL50W.0/120	Stainless steel	DN50	1200 mm		0,8l/s	4082 g	+024872	1
HL50W.0/120.2	Stainless steel	2 x DN50	1200 mm	400 mm	1,4 l/s		+032518	1
HL50W.0/130	Stainless steel	DN50	1300 mm		0,8l/s	4283 g	+024896	1
HL50W.0/130.2	Stainless steel	2 x DN50	1300 mm	400 mm	1,4 l/s		+032525	1
HL50W.0/140	Stainless steel	DN50	1400 mm	500 mm	1,4l/s	6200 g	+030385	1
HL50W.0/150	Stainless steel	DN50	1500 mm	500 mm	1,4l/s	6480 g	+030408	1
HL50W.0/160	Stainless steel	DN50	1600 mm	600 mm	1,4l/s	6780 g	+030422	1
HL50W.0/170	Stainless steel	DN50	1700 mm	600 mm	1,4l/s	6960 g	+030446	1
HL50W.0/180	Stainless steel	DN50	1800 mm	700 mm	1,4l/s	7200 g	+030460	1
HL50W.0/190	Stainless steel	DN50	1900 mm	700 mm	1,4l/s	7450 g	+030484	1
HL50W.0/200	Stainless steel	DN50	2000 mm	800 mm	1,4l/s	7920 g	+030507	1
HL50W.0/210	Stainless steel	DN50	2100 mm	800 mm	1,4l/s	8020 g	+030521	1

HL50WF.0 Shower channel made of stainless steel, installation wall-side (flat version), HEIGHT 90 MM!
Data

Capacity	600 – 1300 mm length = 0,7 l/s 1400 – 2100 mm length = 1,2 l/s
Material	Stainless steel 1.4301/PP
Outlet dimension	DN50 with ball-joint
Height	90 mm
Height of seal water	30 mm
Additional information	removable stretch trap, with angled bar at the back, 5cm surrounding sand-coated flange for a save connection to the under-tile waterproofing. The frameless design makes it possible, to choose border bars, fitting to the tiles and enables under-tile leakage water, to flow into the trap.
Including	Sound absorbing height adjustable levelling legs, butyl tape for a waterproof connection to the wall, tape for sound disconnection, 2 pieces of edge trim jigs, 2 pieces of tiling gauges

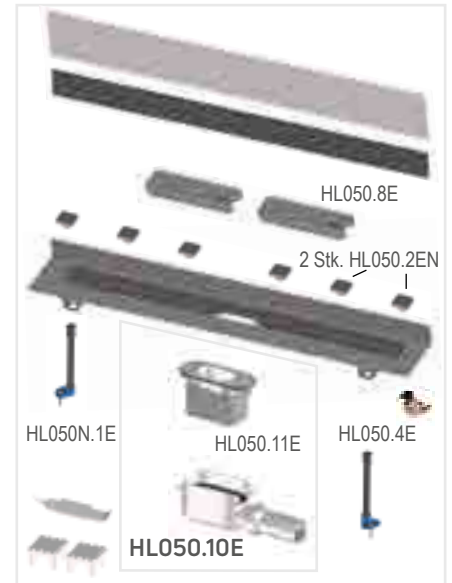
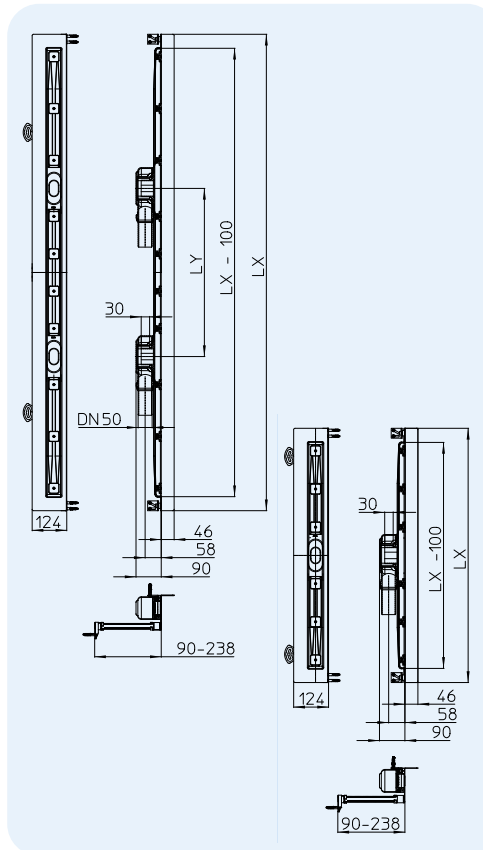

When using ceramic tiles we recommend to produce an individual frame made of tiling profiles.

HL-No.	Material	Dimension	length LX	length LY	Capacity	Weight	EAN	Piece/package
HL50WF.0/60	Stainless steel	DN50	600 mm		0,7 l/s	2409 g	+029716	1
HL50WF.0/70	Stainless steel	DN50	700 mm		0,7 l/s	2655 g	+029723	1
HL50WF.0/80	Stainless steel	DN50	800 mm		0,7 l/s	2965 g	+029587	1
HL50WF.0/90	Stainless steel	DN50	900 mm		0,7 l/s	3248 g	+029594	1
HL50WF.0/90.2	Stainless steel	2 x DN50	900 mm	200 mm	1,2 l/s		+035663	1
HL50WF.0/100	Stainless steel	DN50	1000 mm		0,7 l/s	3462 g	+029730	1
HL50WF.0/100.2	Stainless steel	2 x DN50	1000 mm	300 mm	1,2 l/s		+035670	1
HL50WF.0/110	Stainless steel	DN50	1100 mm		0,7 l/s	3769 g	+029747	1
HL50WF.0/110.2	Stainless steel	2 x DN50	1100 mm	300 mm	1,2 l/s		+035687	1
HL50WF.0/120	Stainless steel	DN50	1200 mm		0,7 l/s	4082 g	+029754	1
HL50WF.0/120.2	Stainless steel	2 x DN50	1200 mm	400 mm	1,2 l/s		+035694	1
HL50WF.0/130	Stainless steel	DN50	1300 mm		0,7 l/s	4283 g	+029709	1
HL50WF.0/130.2	Stainless steel	2 x DN50	1300 mm	400 mm	1,2 l/s		+035700	1
HL50WF.0/140	Stainless steel	DN50	1400 mm	500 mm	1,2 l/s	6200 g	+033447	1
HL50WF.0/150	Stainless steel	DN50	1500 mm	500 mm	1,2 l/s	6480 g	+033454	1
HL50WF.0/160	Stainless steel	DN50	1600 mm	600 mm	1,2 l/s	6780 g	+033461	1
HL50WF.0/170	Stainless steel	DN50	1700 mm	600 mm	1,2 l/s	6960 g	+033478	1
HL50WF.0/180	Stainless steel	DN50	1800 mm	700 mm	1,2 l/s	7200 g	+033485	1
HL50WF.0/190	Stainless steel	DN50	1900 mm	700 mm	1,2 l/s	7450 g	+033492	1
HL50WF.0/200	Stainless steel	DN50	2000 mm	800 mm	1,2 l/s	7920 g	+033508	1
HL50WF.0/210	Stainless steel	DN50	2100 mm	800 mm	1,2 l/s	8020 g	+033515	1

HL50WU.0 Shower channel made of stainless steel, installation wall-side (extra flat), HEIGHT 68 MM!
Data

Capacity	600 - 1300 mm length = 0,46 l/s 1400 - 2100 mm length = 0,82 l/s
Material	Stainless steel 1.4301/PP
Outlet dimension	DN50
Height	68 mm
Height of seal water	24 mm
Additional information	Removable stretch trap, with 5cm surrounding sand coated flange and angled bar at the back for a save connection to the under-tile waterproofing. The frameless design makes it possible, to choose border bars, fitting to the tiles and enables under-tile leakage water, to flow into the trap.
Including	Sound absorbing height adjustable levelling legs, butyl tape for a waterproof connection to the wall, tape for sound disconnection, 2 pieces of edge trim jigs, 2 pieces of tiling gauges.

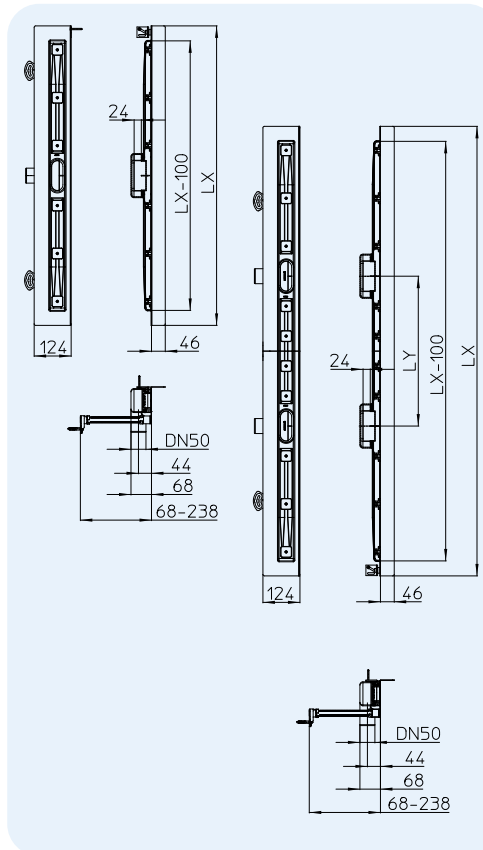

When using ceramic tiles we recommend to produce an individual frame made of tiling profiles.

HL-No.	Material	Dimension	length LX	length LY	Capacity	Weight	EAN	Piece/package
HL50WU.0/60	Stainless steel	DN50	600 mm		0,46 l/s	2409 g		1
HL50WU.0/70	Stainless steel	DN50	700 mm		0,46 l/s	2655 g		1
HL50WU.0/80	Stainless steel	DN50	800 mm		0,46 l/s	2965 g		1
HL50WU.0/90	Stainless steel	DN50	900 mm		0,46 l/s	3248 g		1
HL50WU.0/90.2	Stainless steel	2 x DN50	900 mm	200 mm	0,82 l/s			1
HL50WU.0/100	Stainless steel	DN50	1000 mm		0,46 l/s	3462 g		1
HL50WU.0/100.2	Stainless steel	2 x DN50	1000 mm	300 mm	0,82 l/s			1
HL50WU.0/110	Stainless steel	DN50	1100 mm		0,46 l/s	3769 g		1
HL50WU.0/110.2	Stainless steel	2 x DN50	1100 mm	300 mm	0,82 l/s			1
HL50WU.0/120	Stainless steel	DN50	1200 mm		0,46 l/s	4082 g		1
HL50WU.0/120.2	Stainless steel	2 x DN50	1200 mm	400 mm	0,82 l/s			1
HL50WU.0/130	Stainless steel	DN50	1300 mm		0,46 l/s	4283 g		1
HL50WU.0/130.2	Stainless steel	2 x DN50	1300 mm	400 mm	0,82 l/s			1
HL50WU.0/140	Stainless steel	DN50	1400 mm	500 mm	0,82 l/s	6200 g		1
HL50WU.0/150	Stainless steel	DN50	1500 mm	500 mm	0,82 l/s	6480 g		1
HL50WU.0/160	Stainless steel	DN50	1600 mm	600 mm	0,82 l/s	6780 g		1
HL50WU.0/170	Stainless steel	DN50	1700 mm	600 mm	0,82 l/s	6960 g		1
HL50WU.0/180	Stainless steel	DN50	1800 mm	700 mm	0,82 l/s	7200 g		1
HL50WU.0/190	Stainless steel	DN50	1900 mm	700 mm	0,82 l/s	7450 g		1
HL50WU.0/200	Stainless steel	DN50	2000 mm	800 mm	0,82 l/s	7920 g		1
HL50WU.0/210	Stainless steel	DN50	2100 mm	800 mm	0,82 l/s	8020 g		1

HL50FV.0 Shower channel made of stainless steel, installation in the surface, with vertical outlet
Data

Capacity	600 - 1300 mm length = 0,8 l/s 1400 - 2100 mm length = 1,4 l/s
Material	Stainless steel 1.4301/PP
Outlet dimension	DN50 vertical
Height	See techn. drawing
Standard	EN 1253
Height of seal water	50 mm
Additional information	Removable stretch trap, with 5cm surrounding sand-coated flange for a save connection to the under-tile waterproofing. The frameless design makes it possible, to choose border bars, fitting to the tiles and enables under-tile leakage water to flow into the trap.
Including	Sound absorbing height adjustable levelling legs, 2 pieces of edge trim jigs, 2 pieces of tiling gauges

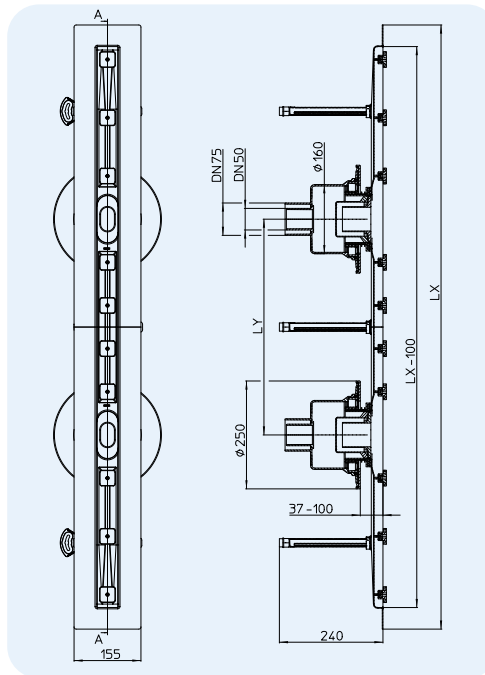
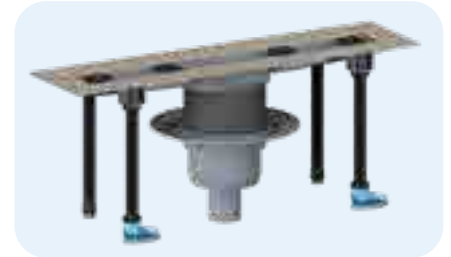
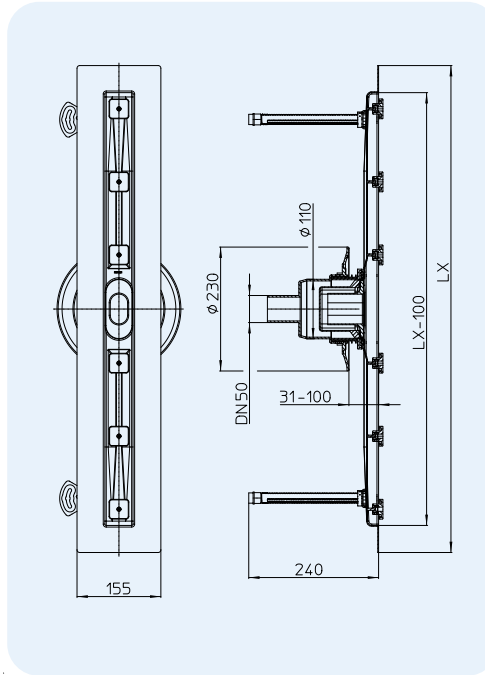

When using ceramic tiles we recommend to produce an individual frame made of tiling profiles.

HL-No.	Material	Dimension	Length LX	Length LY	Capacity	Weight	EAN	Piece/package
50FV.0/60	Stainless steel	DN50	600 mm		0,8 l/s	3760 g	+03792	1
50FV.0/70	Stainless steel	DN50	700 mm		0,8 l/s	3840 g	+03777	1
50FV.0/80	Stainless steel	DN50	800 mm		0,8 l/s	4060 g	+03793	1
50FV.0/90	Stainless steel	DN50	900 mm		0,8 l/s	4100 g	+03773	1
50FV.0/100	Stainless steel	DN50	1000 mm		0,8 l/s	4850 g	+03794	1
50FV.0/110	Stainless steel	DN50	1100 mm		0,8 l/s	5010 g	+03795	1
50FV.0/120	Stainless steel	DN50	1200 mm		0,8 l/s	5210 g	+03796	1
50FV.0/130	Stainless steel	DN50	1300 mm		0,8 l/s	5280 g	+03797	1
50FV.0/140	Stainless steel	DN50	1400 mm	500 mm	1,4 l/s	8250 g	+03798	1
50FV.0/150	Stainless steel	DN50	1500 mm	500 mm	1,4 l/s	8500 g	+03799	1
50FV.0/160	Stainless steel	DN50	1600 mm	600 mm	1,4 l/s	8650 g	+03800	1
50FV.0/170	Stainless steel	DN50	1700 mm	600 mm	1,4 l/s	8900 g	+03801	1
50FV.0/180	Stainless steel	DN50	1800 mm	700 mm	1,4 l/s	9130 g	+03802	1
50FV.0/190	Stainless steel	DN50	1900 mm	700 mm	1,4 l/s	9380 g	+03803	1
50FV.0/200	Stainless steel	DN50	2000 mm	800 mm	1,4 l/s	9620 g	+03804	1
50FV.0/210	Stainless steel	DN50	2100 mm	800 mm	1,4 l/s	9870 g	+03805	1

HL050S Cover plate „Standard“, made of stainless steel - for shower channels

Data

Material	Stainless steel 1.4301
Height	Usage for floorings from 2 – 16 mm including tile glue
Load classification	K3 (300 kg)

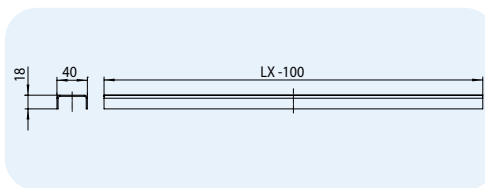

HL-No.	Material	length LX -100	Weight	EAN	Piece/package	HL-No.	Material	length LX -100	Weight	EAN	Piece/package
050S/60	Stainless steel	500 mm	410 g	+024919	1	050S/140	Stainless steel	1300 mm	1074 g	+029891	1
050S/70	Stainless steel	600 mm	490 g	+024933	1	050S/150	Stainless steel	1400 mm	1156 g	+029914	1
050S/80	Stainless steel	700 mm	583 g	+024957	1	050S/160	Stainless steel	1500 mm	1238 g	+029938	1
050S/90	Stainless steel	800 mm	672 g	+024971	1	050S/170	Stainless steel	1600 mm	1320 g	+029952	1
050S/100	Stainless steel	900 mm	746 g	+024995	1	050S/180	Stainless steel	1700 mm	1402 g	+029976	1
050S/110	Stainless steel	1000 mm	830 g	+025015	1	050S/190	Stainless steel	1800 mm	1484 g	+029990	1
050S/120	Stainless steel	1100 mm	900 g	+025039	1	050S/200	Stainless steel	1900 mm	1566 g	+030026	1
050S/130	Stainless steel	1200 mm	992 g	+025053	1	050S/210	Stainless steel	2000 mm	1648 g	+030040	1

HL050D Cover plate „Design“, made of stainless steel - for shower channels

Data

Material	Stainless steel 1.4301 brushed finish
Height	Usage for floorings from 5 – 19 mm including tile glue
Load classification	K3 (300 kg)

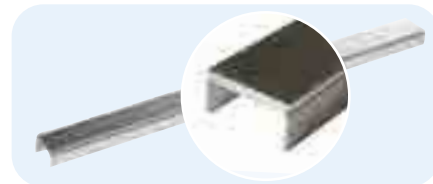
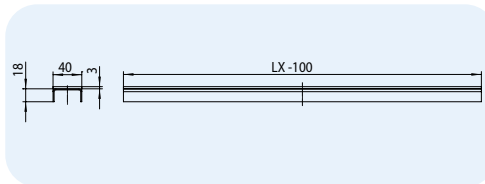

HL-No.	Material	length LX -100	Weight	EAN	Piece/package	HL-No.	Material	length LX -100	Weight	EAN	Piece/package
050D/60	Stainless steel	500 mm	872 g	+025077	1	050D/140	Stainless steel	1300 mm	2322 g	+603007	1
050D/70	Stainless steel	600 mm	1041 g	+025091	1	050D/150	Stainless steel	1400 mm	2528 g	+603009	1
050D/80	Stainless steel	700 mm	1260 g	+025114	1	050D/160	Stainless steel	1500 mm	2734 g	+603011	1
050D/90	Stainless steel	800 mm	1395 g	+025138	1	050D/170	Stainless steel	1600 mm	2940 g	+603013	1
050D/100	Stainless steel	900 mm	1550 g	+025152	1	050D/180	Stainless steel	1700 mm	3146 g	+603015	1
050D/110	Stainless steel	1000 mm	1757 g	+025176	1	050D/190	Stainless steel	1800 mm	3352 g	+603017	1
050D/120	Stainless steel	1100 mm	1954 g	+025190	1	050D/200	Stainless steel	1900 mm	3558 g	+603019	1
050D/130	Stainless steel	1200 mm	2116 g	+025213	1	050D/210	Stainless steel	2000 mm	3764 g	+603021	1

HL050I Cover plate „Individuell“, made of stainless steel - for shower channels

Data

Material	Stainless steel 1.4301 brushed finish
Height	Usage for floorings from 16 – 30 mm including tile glue
Load classification	K3 (300 kg)
Additional information	with recess for customers individual floor finish

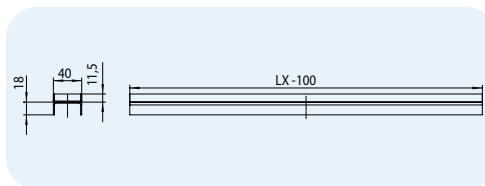

HL-No.	Material	length LX -100	Weight	EAN	Piece/package	HL-No.	Material	length LX -100	Weight	EAN	Piece/package
050I/60	Stainless steel	500 mm	766 g	+025237	1	050I/140	Stainless steel	1300 mm	2003 g	+030224	1
050I/70	Stainless steel	600 mm	914 g	+025251	1	050I/150	Stainless steel	1400 mm	2151 g	+030248	1
050I/80	Stainless steel	700 mm	1060 g	+025275	1	050I/160	Stainless steel	1500 mm	2299 g	+030262	1
050I/90	Stainless steel	800 mm	1213 g	+025299	1	050I/170	Stainless steel	1600 mm	2447 g	+030286	1
050I/100	Stainless steel	900 mm	1412 g	+025312	1	050I/180	Stainless steel	1700 mm	2595 g	+030309	1
050I/110	Stainless steel	1000 mm	1488 g	+025336	1	050I/190	Stainless steel	1800 mm	2743 g	+030323	1
050I/120	Stainless steel	1100 mm	1723 g	+025350	1	050I/200	Stainless steel	1900 mm	2891 g	+030347	1
050I/130	Stainless steel	1200 mm	1855 g	+025374	1	050I/210	Stainless steel	2000 mm	3039 g	+030361	1

HL050.3EN Adjustment screws for the precise cover height

Data

Material	PP
Recommended for	For the adapting of the cover plates to higher floorings, like natural stones



Shower channel	Requ. quant. of sets	Used cover plate	Adjustable in height
60 – 70 cm	2	Standard	15 – 29 mm
80 – 110 cm	3		
120 – 130 cm	4	Design	18 – 32 mm
140 – 180 cm	5		
190 – 210 cm	6	Individuell	29 – 43 mm

HL-No.	Material	Weight	EAN	Piece/package
050.3EN	PP	296 g	+025862	1

HL53 - System family

Design cover HL053M - massive stainless steel, **brushed**; length: from 80cm to 150cm

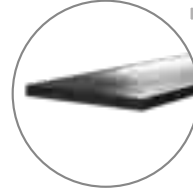

Design cover HL053P - massive stainless steel, **polished**; length: from 80cm to 150cm

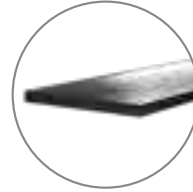

Design cover HL053S - stainless steel, **brushed**; length: 90cm, 100cm and 120cm

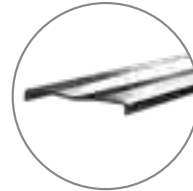

„Wall“ Standard cover HL053WS - stainless steel, **brushed**; Length: 90cm, 100cm or 120cm

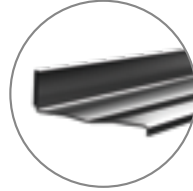

„Wall“ Design cover „duo-wall“ HL053M.2 - massive stainless steel **brushed**; Length: from 130cm to 200cm

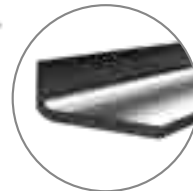

„Wall“ Design cover „duo-wall“ HL053P.2 - massive stainless steel **polished**; Length: from 130cm to 200cm



HL53 - System family



Drain body HL53.0
Height 90 mm
Flow rate: 0,83 l/s



Drain body HL53Prblue.0
Height: 90 mm
Flow rate: 0,55 l/s



Drain body HL53V.0
Vertical outlet
Flow rate: 0,98 l/s



Drain body HL53FPblue.0
Height: 65 mm
Flow rate: 0,48 l/s

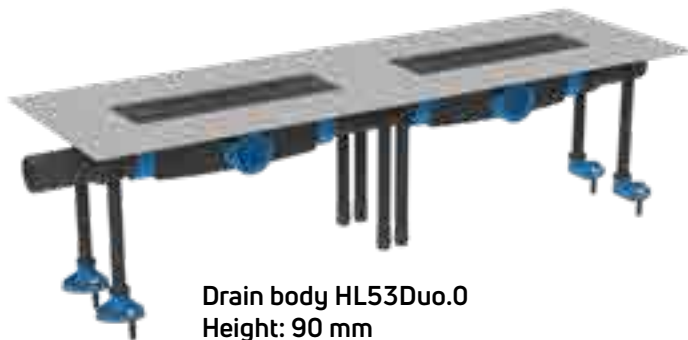

Drain body HL53Duo.0
Height: 90 mm
Flow rate: 1,45 l/s

HL53.0 Drain body for showerchannel, MIN. HEIGHT 90 MM !
HL53Prblue.0 Drain body for showerchannel, MIN. HEIGHT 90 MM !

Data	
Capacity	above drain level 10 mm 20 mm HL53.0: 0,61 l/s 0,83 l/s HL53Prblue.0: 0,45 l/s 0,55 l/s
Material	PP
Outlet	DN50
Height	90 - 250 mm adjustable
Standard	EN 1253
Odor trap	HL53.0: 50 mm HL53Prblue.0: New Primus blue combined trap with sealing water and mechanical odor barrier (absolutely odor-tight even without water). backflowproof up to 30 cm water column
Fits to	HL053S, HL053WS, HL053M(P), HL052M(P)
Additional information	Incl. removable trap and flexible waterproofing membrane.
Installation	Installation wallside or in the surface. Please see movie www.hl.at

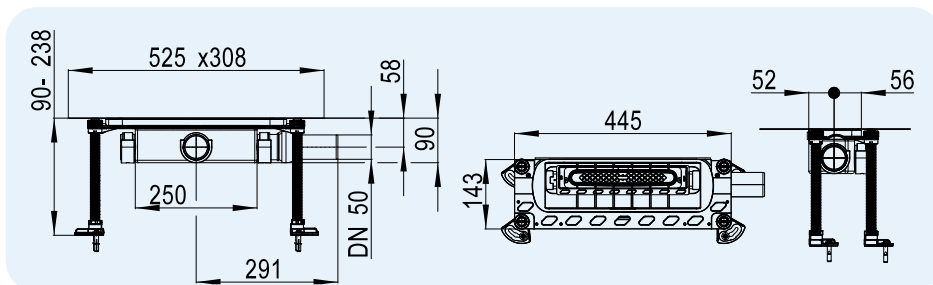
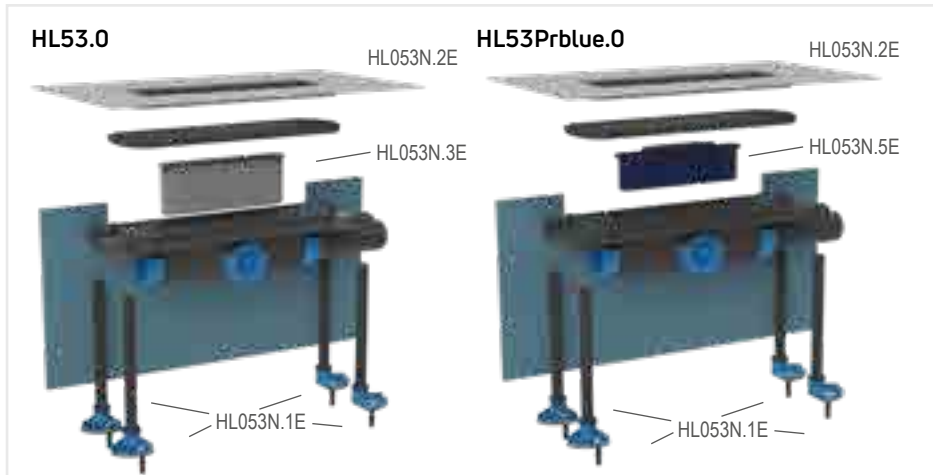

HL-No.	Material	Dimension	Weight	EAN	Piece/package
53.0	PP	DN50		+003846	1
53Prblue.0	PP	DN50		+003822	1

HL53FPblue.0 Drain body flat for showerchannel, MIN. HEIGHT 65 MM !

Data	
Capacity	above drain level 10 mm: 0,39 l/s above drain level 20 mm: 0,48 l/s
Material	PP
Outlet	DN40
Height	65 - 250 mm adjustable
Standard	EN 1253
Odor trap	New Primus blue , combined odor trap with sealing water and mechanical odor barrier (absolutely odor-tight even without water). Backflow-proof up to 30 cm accumulation height.
Fits to	HL053S, HL053WS, HL053M(P), HL052M(P)
Additional information	Incl. removable trap and flexible waterproofing membrane.
Installation	Installation wallside or in the surface. Please see movie www.hl.at

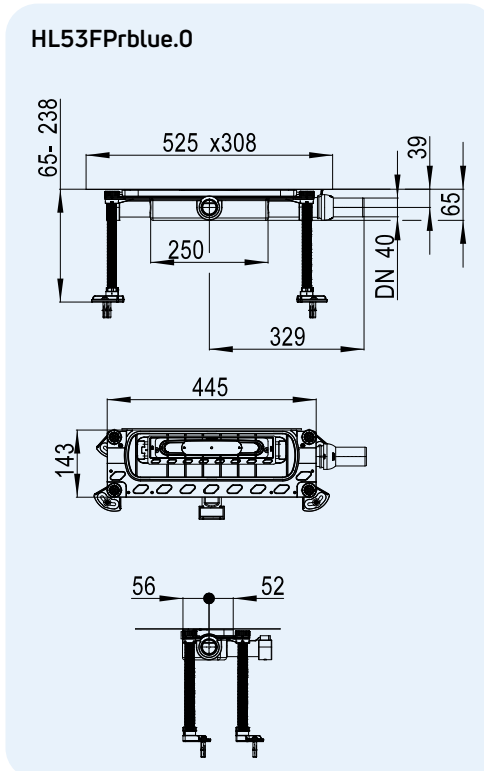

HL-No.	Material	Dimension	Weight	EAN	Piece/package
53FPblue.0	PP	DN40		+003907	1

HL53Duo.0 Drain body for shower channel HL053M(P).2, INSTALLATION HEIGHT 90 MM!
Data

Capacity	20 mm above drain level: 1,45l/s; 10 mm above drain level: 0,9l/s;
Material	PP
Outlet	HL53Duo.0: 2 x DN50
Installation height	HL53Duo.0: 90 - 250 mm adjustable
Standard	EN 1253
Odor trap	50 mm water trap
Fits to	HL053M.2, HL053P.2
Additional information	incl. removable water traps, 2 flexible waterproof membranes and fixing legs; installation only close to the wall;
Installation	Only close to the wall

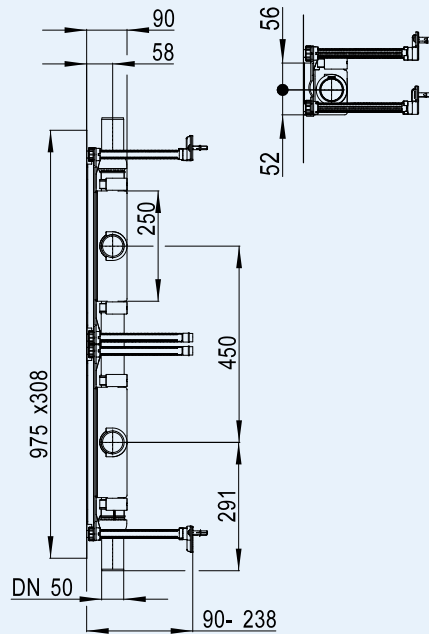
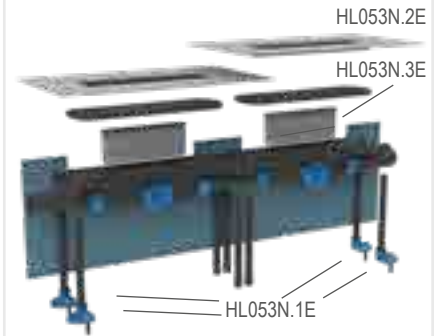
HL53Duo.0

HL53Duo.0

HL-No.	Material	Dimension	Weight	EAN	Piece/package
53Duo.0	PP	2 x DN50		+003884	1

HL53V.0 Drain body vertical for showerchannel
Data

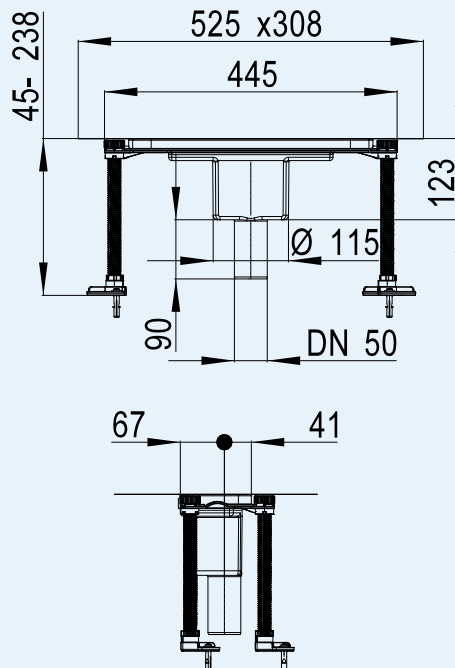
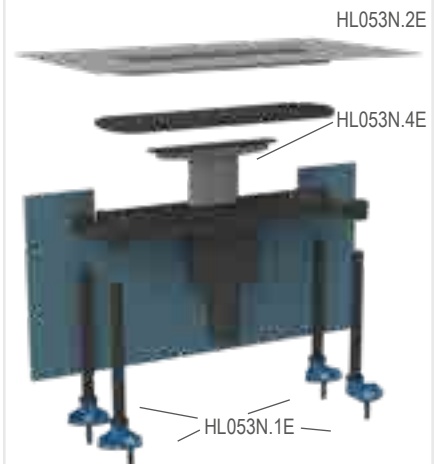
Capacity	20 mm above drain level: 0,93 l/s 10 mm above drain level: 0,98 l/s
Material	PP
Outlet	DN50
Installation height	30 - 131 mm adjustable
Standard	EN 1253
Odor trap	50 mm water trap
Fits to	HL053S, HL053WS, HL053M(P), HL052M(P)
Additional information	Incl. removable odor trap and flexible waterproofing membrane, installation in the surface or close to the wall, incl. 4 adjustable fixing legs
Installation	In the surface of the shower or close to the wall

HL53V.0

HL53V.0

HL-No.	Material	Dimension	Weight	EAN	Piece/package
53V.0	PP	DN50		+003945	1

HL053M/.... Design shower channel made of matt stainless steel with integrated cross slope
HL053P/... Design shower channel made of polished stainless steel with integrated cross slope
Data

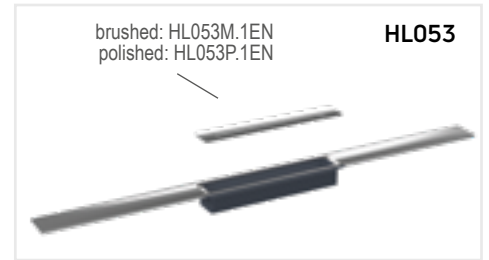
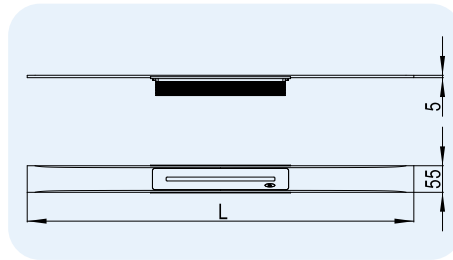
Material	Stainless steel V2A (1.4301) massive 6mm
Please see chart	Please see chart
Load classification	K3 - max. 300 kg
Fits to	HL53.0, HL53Prblue.0, HL53FPblue.0, HL53V.0
Additional information	In combination with drain body HL53K(F), drainage strip with multiple precision slope usage for: floor tiles 8 - 36 mm and wall tiles 8 - 25 mm (incl. tile glue)
Included	Installation accessories and lot cover
Installation	Installation wallside or in the surface.



HL-No.	Material	Dimension	Surface	Weight	EAN	Piece/package
053M/80	Stainless steel V2A	800 x 55 x 5 mm	matt	3650 g	+041428	1
053M/90	Stainless steel V2A	900 x 55 x 5 mm	matt	3950 g	+041282	1
053M/100	Stainless steel V2A	1000 x 55 x 5 mm	matt	4300 g	+041305	1
053M/110	Stainless steel V2A	1100 x 55 x 5 mm	matt	4550 g	+041312	1
053M/120	Stainless steel V2A	1200 x 55 x 5 mm	matt	4700 g	+041329	1
053M/130	Stainless steel V2A	1300 x 55 x 5 mm	matt	4850 g	+041336	1
053M/140	Stainless steel V2A	1400 x 55 x 5 mm	matt	5150 g	+041343	1
053M/150	Stainless steel V2A	1500 x 55 x 5 mm	matt	5450 g	+041350	1
053P/80	Stainless steel V2A	800 x 55 x 5 mm	polished	3650 g	+041428	1
053P/90	Stainless steel V2A	900 x 55 x 5 mm	polished	3950 g	+041466	1
053P/100	Stainless steel V2A	1000 x 55 x 5 mm	polished	4300 g	+041367	1
053P/110	Stainless steel V2A	1100 x 55 x 5 mm	polished	4550 g	+041374	1
053P/120	Stainless steel V2A	1200 x 55 x 5 mm	polished	4700 g	+041381	1
053P/130	Stainless steel V2A	1300 x 55 x 5 mm	polished	4850 g	+041398	1
053P/140	Stainless steel V2A	1400 x 55 x 5 mm	polished	5150 g	+041404	1
053P/150	Stainless steel V2A	1500 x 55 x 5 mm	polished	5450 g	+041411	1

HL053S/.... Shower channel „Standard“ made of stainless steel with integrated cross slope
Data

Material	Stainless steel V2A (1.4301)
Dimensions	please see chart
Load classification	K3 - max. 300 kg
Fits to	HL53.0, HL53Prblue.0, HL53FPblue.0, HL53V.0
Additional information	in combination with drain body HL53K(F), drainage strip with integrated cross slope; usage for floor tiles 8 - 36 mm and wall tiles 8 - 25 mm (incl. tile glue). may be cut to minimum length of 450mm
Including	Installation accessories and lot cover
Installation	Installation wallside or in the surface.

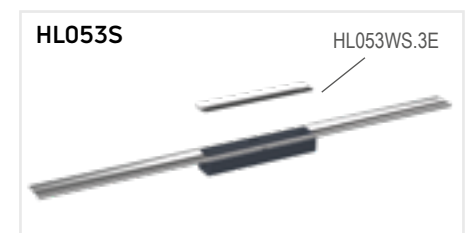
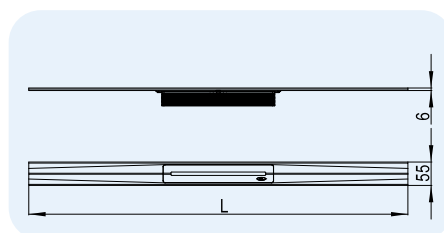

HL-No.	Material	Dimension	Surface	Weight	EAN	Piece/package
053S/90	Stainless steel V2A	900 x 55 x 1,5 mm	matt	1350 g	+045211	1
053S/100	Stainless steel V2A	1000 x 55 x 1,5 mm	matt	1350 g	+045198	1
053S/120	Stainless steel V2A	1200 x 55 x 1,5 mm	matt	1360 g	+045204	1

HL053M.2/... „Wall“ DUO design shower channel, brushed stainless steel
HL053P.2/... „Wall“ DUO design shower channel, polished stainless steel

Data

Material	Massive stainless steel V2A (1.4301) - 6mm
Size	See sheet below
Load classification	K3 - max. 300 kg
Fits to	HL53Duo.0
Additional information	Installation in combination with double drain body DUO. Channel with 2 inlets and wall angle, position only close to the wall; Channel with lateral shaped slope. Usable for floor tiles from 12 to 28 mm and wall tiles from 12 - 28 mm (incl. tile glue)
Including	Installation accessories and lot cover
Installation	Only close to the wall

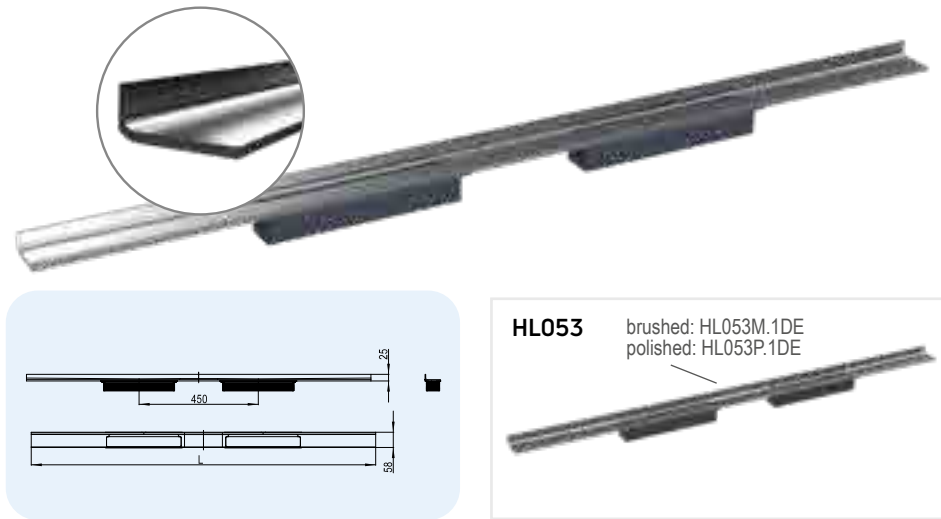

HL-No.	Material	Dimension	Surface	Weight	EAN	Piece/package
HL053M.2/130	Stainless steel V2A	1300 x 58 x 25 mm	matt	4700 g	+047642	1
HL053M.2/140	Stainless steel V2A	1400 x 58 x 25 mm	matt	5050 g	+047659	1
HL053M.2/150	Stainless steel V2A	1500 x 58 x 25 mm	matt	5330 g	+047666	1
HL053M.2/160	Stainless steel V2A	1600 x 58 x 25 mm	matt	5490 g	+047673	1
HL053M.2/170	Stainless steel V2A	1700 x 58 x 25 mm	matt	5560 g	+047680	1
HL053M.2/180	Stainless steel V2A	1800 x 58 x 25 mm	matt	6000 g	+047697	1
HL053M.2/190	Stainless steel V2A	1900 x 58 x 25 mm	matt	6100 g	+047703	1
HL053M.2/200	Stainless steel V2A	2000 x 58 x 25 mm	matt	6400 g	+047710	1
HL053P.2/130	Stainless steel V2A	1300 x 58 x 25 mm	polished	4670 g	+047727	1
HL053P.2/140	Stainless steel V2A	1400 x 58 x 25 mm	polished	4920 g	+047734	1
HL053P.2/150	Stainless steel V2A	1500 x 58 x 25 mm	polished	5200 g	+047741	1
HL053P.2/160	Stainless steel V2A	1600 x 58 x 25 mm	polished	5470 g	+047758	1
HL053P.2/170	Stainless steel V2A	1700 x 58 x 25 mm	polished	5750 g	+047765	1
HL053P.2/180	Stainless steel V2A	1800 x 58 x 25 mm	polished	6120 g	+047772	1
HL053P.2/190	Stainless steel V2A	1900 x 58 x 25 mm	polished	6280 g	+047789	1
HL053P.2/200	Stainless steel V2A	2000 x 58 x 25 mm	polished	6550 g	+047796	1

HL053WS „Wall“ Shower channel „standard“, stainless steel with wallside angle and integrated cross slope

Data

Material	Stainless steel V2A (1.4301)
Dimensions	please see chart
Load classification	K3 - max. 300 kg
Fits to	HL53.0, HL53Prblue.0, HL53FPPrblue.0, HL53V.0
Additional information	Additional Installation in combination with drain body HL53-series, shower information channel with integrated cross slope and 2 cm wallside angle. For floor tiles 8 - 36 mm and wall tiles 8 - 28 mm (incl. tile glue). Minimum cuttable size: 450 mm
Including	Installation accessories and lot cover
Installation	Only close to the wall

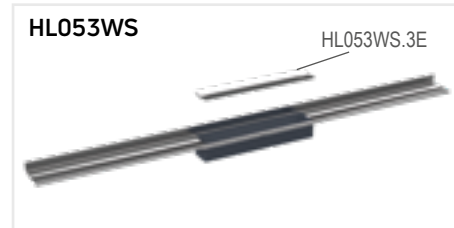
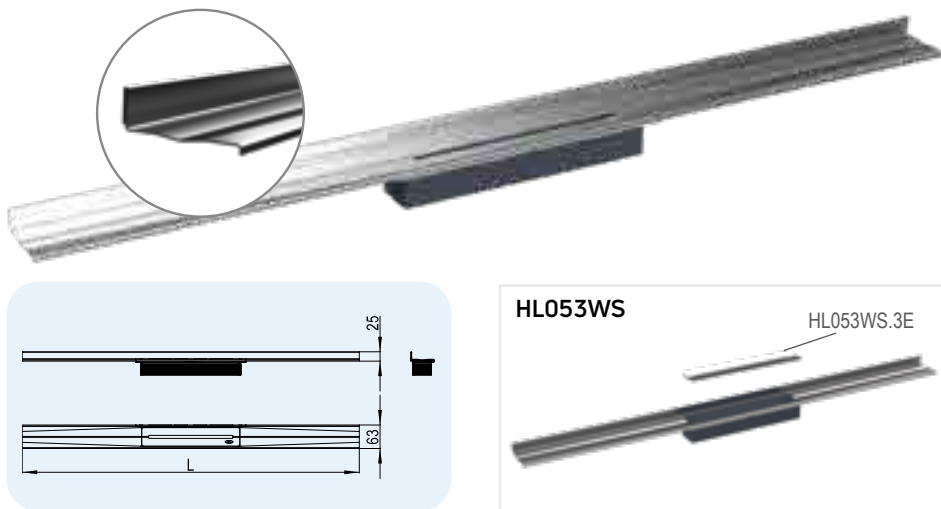

HL-No.	Material	Dimension	Surface	Weight	EAN	Piece/package
053WS/90	Stainless steel V2A	900 x 63 x 25 mm	matt	1350 g	+048991	1
053WS/100	Stainless steel V2A	1000 x 61 x 20 mm	matt	1360 g	+048977	1
053WS/120	Stainless steel V2A	1200 x 61 x 20 mm	matt	1380 g	+048984	1

HL531Prblue Shower channel Primus blue with stainless steel frame and cover, HEIGHT 75 MM !
HL531Prblue.1(2)(3) Shower channel Primus blue with stainless steel frame in color, HEIGHT 75 MM !

Data

Description	Shower channel, integrated in an EPS element with stainless steel frame and cover. Surface is waterproof fleece-laminated. For installation on the wall.
Drainage capacity	accumulation height 10 mm 20 mm 0.5 l/s 0.6 l/s
Material	PP/ABS/EPS-40/ stainless steel V2A
Inlet	Stainless steel frame 500 x 86 x 13 mm, cover 486 x 56 mm
Outlet	DN50 horizontal
Standard	EN 1253
Odor trap	New Primus blue, combined trap with sealing water and mechanical odor barrier (absolutely odor-tight even without water). Backflow- proof up to 30 cm accumulation height.
Installation	The exact adjustment of the shower channel is made by simply cutting the EPS element to length on site. Length from 600mm to 1200mm, width 190 mm, height 75mm incl. 2% slope to the wall. For Wall tiles from 5 mm to 17mm and floor tiles 13mm (incl. adhesive). Can be extended with HL531V. See also installation movie at www.hl.at

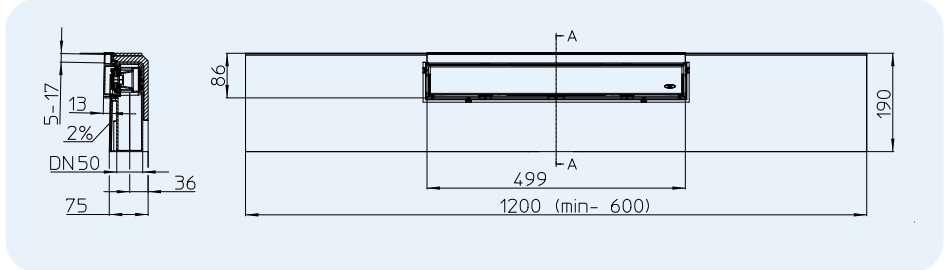

HL-No.	Visible part	Dimension	Frame height	Material	Weight	EAN	Piece/Package
531Prblue	Cover Standard Stainless steel mat	1200 x 190 x 75 mm	13	PP/EPS-40/stainless steel V2A		+051571	1
531Prblue-l	Cover Individual Stainless steel mat	1200 x 190 x 75 mm	13	PP/EPS-40/stainless steel V2A		+051670	1
531Prblue.0	Stainless steel mat, without cover	1200 x 190 x 75 mm	13	PP/EPS-40/stainless steel V2A		+051595	1
531Prblue.1	PVD-coated black matt, without cover	1200 x 190 x 75 mm	13	PP/EPS-40/stainless steel V2A		+051601	1
531Prblue.2	PVD-coated rose gold matt, without cover	1200 x 190 x 75 mm	13	PP/EPS-40/stainless steel V2A		+051618	1
531Prblue.3	PVD-coated brass matt, without cover	1200 x 190 x 75 mm	13	PP/EPS-40/stainless steel V2A		+051625	1

HL531V Elongation element for HL531Prblue

Data

Material	EPS-40
Additional information	To elongate shower channel HL531Prblue, e.g. for multiple shower facilities. May be cut to any length, with fleece-laminated surface.

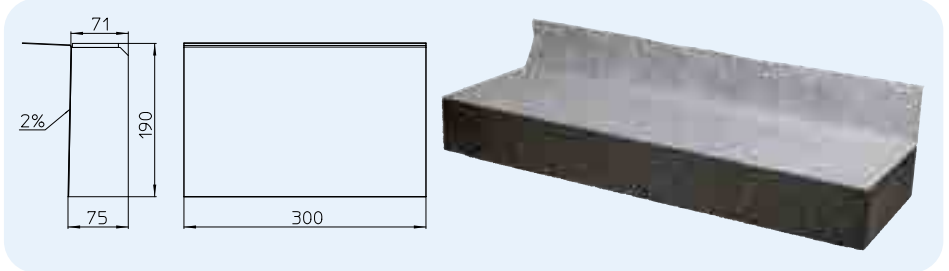

HL-No.	Material	Dimension	Weight	EAN	Piece/package
531V	EPS-40	300 x 190 x 75 mm			1

HL0531Prblue-S Cover Standard for shower channel HL531Prblue, available in 4 different colors

HL0531Prblue-D Cover Design for shower channel HL531Prblue, available in 4 different colors

HL0531Prblue-I Cover Individual for shower channel HL531Prblue, available in 4 different colors

Data

Material	Stainless steel V2A, Colors: PVD-coated
Dimensions	HL0531Prblue-S: 486 x 56 mm HL0531Prblue-D: 486 x 56 mm HL0531Prblue-I: Gap for tile: 480 x 50 mm, depth 12 mm
Load classification	K3 - max. 300 kg

HL0531Prblue-S „Standard“

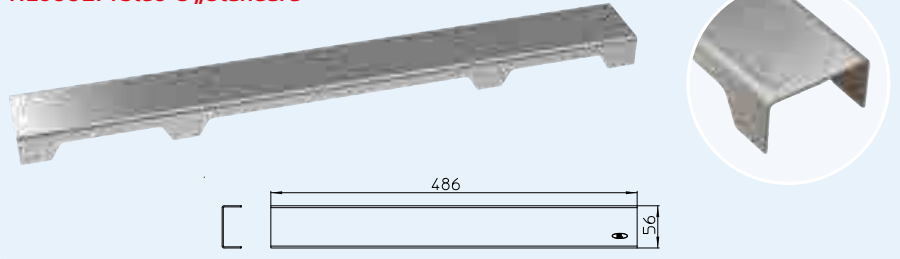

HL0531Prblue-D „Design“

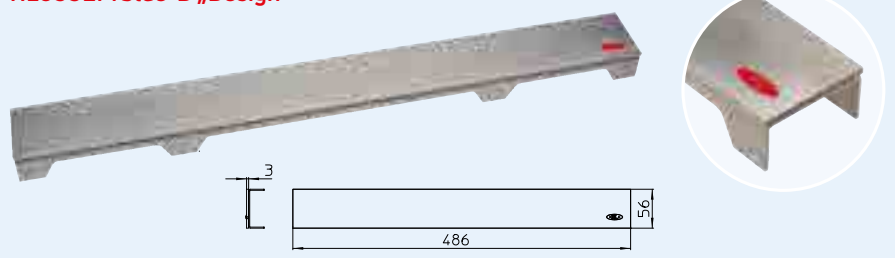

HL0531Prblue-I „Individual“

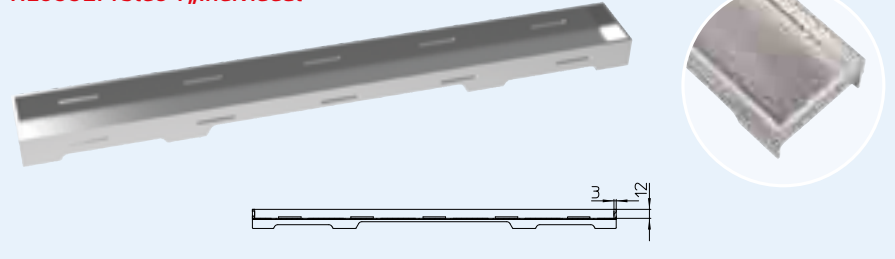

HL-No.	Visible part / Color	Dimension	Material	Weight	EAN	Piece/Package
HL0531Prblue-S	Stainless steel mat Standard	486 x 56 mm	PP/EPS-40/stainless steel V2A		+051717	1
HL0531Prblue-S.1	PVD-coated black mat Standard	486 x 56 mm	PP/EPS-40/stainless steel V2A		+051724	1
HL0531Prblue-S.2	PVD-coated rose gold mat Standard	486 x 56 mm	PP/EPS-40/stainless steel V2A		+051731	1
HL0531Prblue-S.3	PVD-coated brass mat Standard	486 x 56 mm	PP/EPS-40/stainless steel V2A		+051748	1
HL0531Prblue-D	Stainless steel mat Design	486 x 56 mm	PP/EPS-40/stainless steel V2A		+051632	1
HL0531Prblue-D.1	PVD-coated black mat Design	486 x 56 mm	PP/EPS-40/stainless steel V2A		+051649	1
HL0531Prblue-D.2	PVD-coated rose gold mat Design	486 x 56 mm	PP/EPS-40/stainless steel V2A		+051656	1
HL0531Prblue-D.3	PVD-coated brass mat Design	486 x 56 mm	PP/EPS-40/stainless steel V2A		+051663	1
HL0531Prblue-I	Stainless steel mat Individual	486 x 56 mm	PP/EPS-40/stainless steel V2A		+051670	1
HL0531Prblue-I.1	PVD-coated black mat Individual	486 x 56 mm	PP/EPS-40/stainless steel V2A		+051687	1
HL0531Prblue-I.2	PVD-coated rose gold mat Individual	486 x 56 mm	PP/EPS-40/stainless steel V2A		+051694	1
HL0531Prblue-I.3	PVD-coated brass mat Individual	486 x 56 mm	PP/EPS-40/stainless steel V2A		+051700	1



Stainless
steel mat



brass
mat



rose gold
mat



black
mat

HL540 „Primus Drain“ Shower drain, MIN. HEIGHT 80 MM !
HL540I „Primus Drain“ Shower drain with individual tile hollow, MIN. HEIGHT 80 MM !

Data

Capacity	20 mm above drain level: HL540=0,8l/s; HL540i=0,6/s 10 mm above drain level: HL540=0,55l/s; HL540i=0,45l/s
Material	PP/stainless steel, Frame: V4A Grate HL540=V2A Grate HL540i=V4A
Outlet	DN50 horizontal
Height	from 8 - 20 cm adjustable
Standard	EN 1253
Stench trap	5cm seal water, incl. Primus-trap, no stench without seal water
Additional information	incl. removable trap inlet, sealing kit with textile coated membrane, sound disconnected adjusting angles, protection cover and lot cover
Installation	Soundproofing tested Test certificate: www.hl.at The drain body might be fixed on the floor with 3 metal angles and can be adjusted in height afterwards. Advantage: maximum sced covering of the outlet pipe. New: It is no longer necessary to set the drain exactly on the right height of the screed. After filling in the screed, the salient nozzle is cut by a saw. The sealing kit may be inserted without any tools and takes care of a safe connection to the waterproofing. At the end the extension is adjusted and set into the drain. Please take care, that the edges of the frame are underlaid with tile glue to take maximum load.

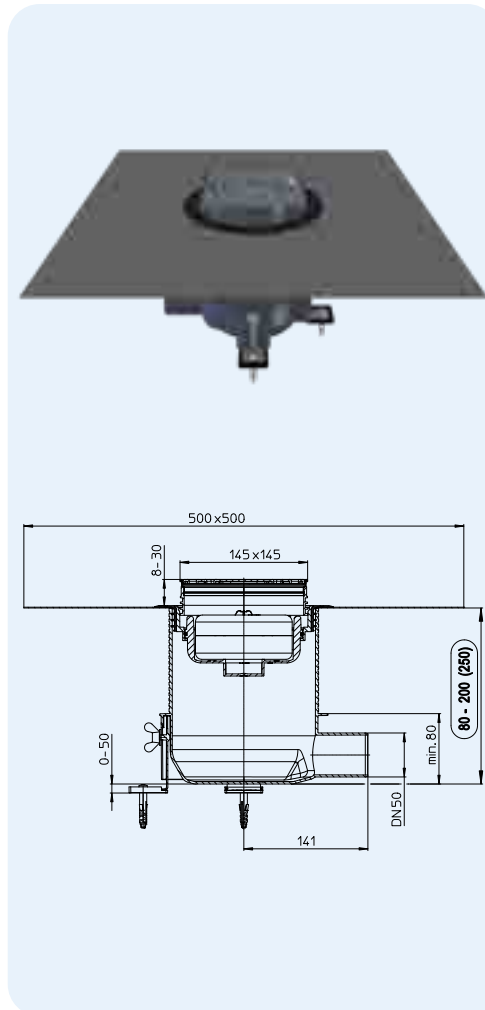

Please also see
installation movie at
www.hl.at

HL-No.	Material	Dimension	Weight	EAN	Piece/package
540	PP/Stainless steel	DN50	1533 g	+039029	1
540I	PP/Stainless steel	DN50	1898 g	+039098	1
540-Quadra	PP/Stainless steel	DN50	1898 g	+041817	1
540-Cut	PP/Stainless steel	DN50	1898 g	+041800	1
540-Hamam	PP/Stainless steel/ PVD-coated	DN50	1898 g	+041824	1

HL066Q.1E, HL066C.1E, HL0540I, HL3928, HL3128E Design grates

Data

Material	Stainless steel
Grate	HL540I: 138x138mm massive, Tile hollow: 74x74 mm, depth 13mm
Load classification	HL540: L - max. 1,5t, HL540i: K3 - max. 300kg
Recommended for	Shower drain HL540 or floor drain series HL5100, HL3100, HL72.1 and HL317

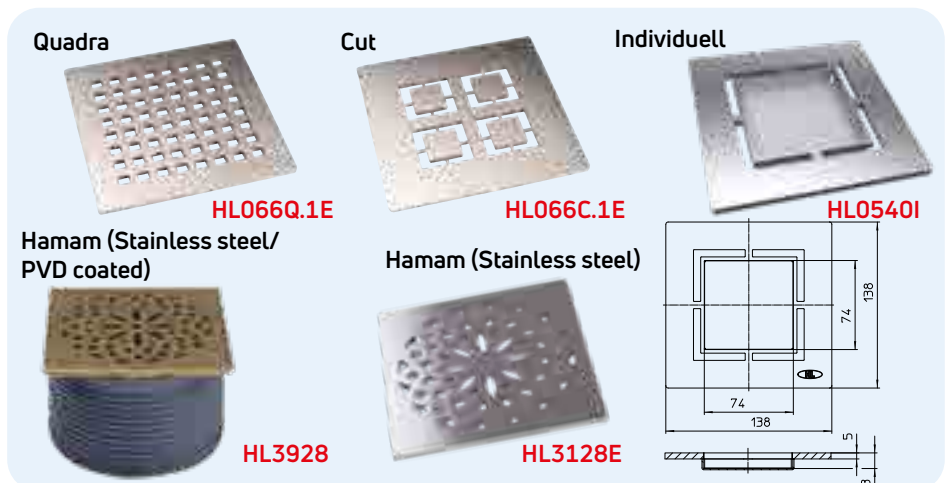

HL-No.	Material	Dimension	Weight	EAN	Piece/package
066Q.1E	Stainless steel V4A	138 x 138 x 5 mm	607 g	+013623	1
066C.1E	Stainless steel V4A	138 x 138 x 5 mm	608 g	+031283	1
0540I	Stainless steel V4A	138 x 138 x 5 mm	638 g	+039104	1
3928	Stainless steel/PVD coated V4A	138 x 138 x 5 mm	608 g	+031283	1
3128E	Stainless steel V4A	138 x 138 x 5 mm	595 g	+037094	1

HL541 Primus blue Flat shower drain, MIN. HEIGHT 62MM!

HL541I Primus blue Flat shower drain with individual tile hollow, MIN. HEIGHT 62MM!

Data

Capacity 20 mm above drain level:
HL541=0,5l/s; HL541i=0,45/s
10 mm above drain level:
HL541=0,4l/s; HL541i=0,4l/s

Material PP/stainless steel, Frame: V4A
Grate HL541=V2A
Grate HL541i=V4A

Outlet DN40/DN50 horizontal

Height from 62 - 200 (230) mm

Standard EN 1253

Load classification K3 - max. 300 kg

Odor trap New **Primus blue**, combined odor trap with sealing water and mechanical odor barrier (absolutely odor-tight even without water). Backflow-proof up to 50 cm accumulation height.

Additional information Incl. removable trap inlet, sealing kit with fleece laminated membrane, adjustable fixing angles, hair catcher, lot cover and protection cover.

Soundproofing tested
Test certificate: www.hl.at

Installation The drain body might be fixed on the floor with 3 metal angles and can be adjusted in height afterwards. Advantage: maximum speed covering of the outlet pipe. New: It is no longer necessary to set the drain exactly on the right height of the screed. After filling in the screed, the salient nozzle is cut by a saw. The sealing kit may be inserted without any tools and takes care of a safe connection to the waterproofing. At the end the extension is adjusted and set into the drain. Please take care, that the edges of the frame are underlaid with tile glue to take maximum load.

Please also see installation movie and movie „function of Primus blue“ at www.hl.at

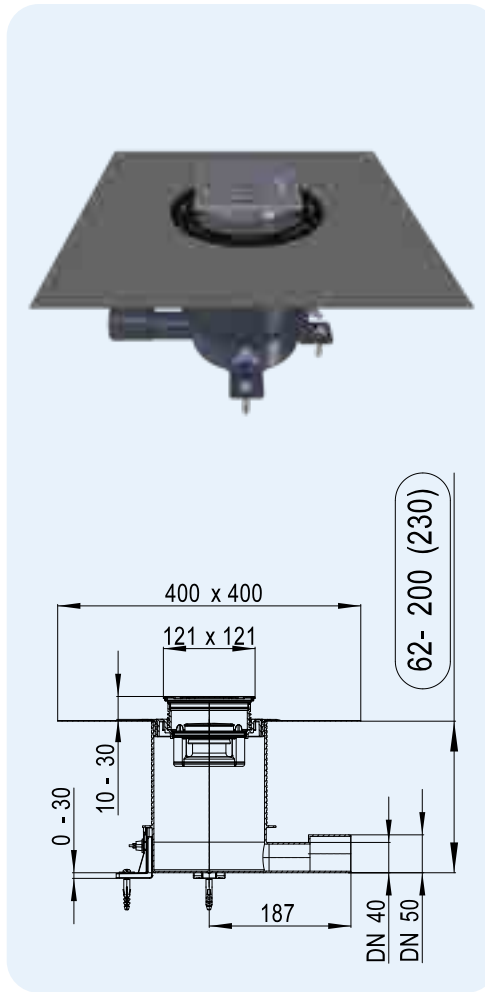

HL-No.	Material	Dimension	Weight	EAN	Piece/package
HL541	PP/Stainless steel	DN40/50	1121 g	+047642	1
HL541I	PP/Stainless steel	DN40/50	1388 g	+047659	1
HL541-Quadra	PP/Stainless steel	DN40/50	1819 g	+048236	1

HL0541I, HL3120, HL3121, HL3122, HL3123, HL3124, HL3125, HL3127 Design grates

Daten

Material Stainless steel V2A

Grate Stainless steel grate 115 x 115 mm

Load classification L – max. 1,5 t

Recommended for Floor drain series HL70, HL80, HL300, HL304, HL310N, HL510N, HL90 combined with extensions HL3200 or HL3210
HL0541I: HL541

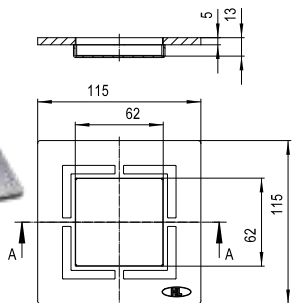
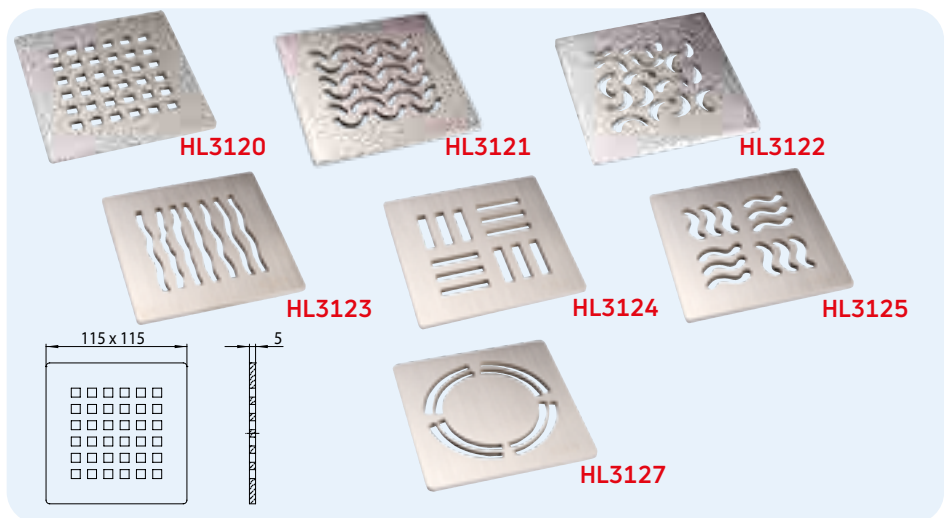

HL-No.	Dimension	Weight	EAN	Piece/package
3120	115 x 115 mm	425 g	+015412	1
3121	115 x 115 mm	425 g	+015429	1
3122	115 x 115 mm	425 g	+015443	1
3123	115 x 115 mm	425 g	+015443	1
3124	115 x 115 mm	425 g	+015450	1
3125	115 x 115 mm	425 g	+015467	1
3127	115 x 115 mm	430 g	+029037	1
0541I	115 x 115 mm	800 g	+048304	1

HL542Prblue Shower drain for coated floor coverings HL542Prblue.0 Floor drain, without waterproofing fleece

Data

Capacity	0,4 l/s
Material	PP, Stainless steel V4A
Outlet dimension	DN40/50 horizontal
Constr. height	63 - 200 mm (230 mm)
Standard	EN 1253
Load class	K3 - max. 300 kg
Odour barrier	New Primus blue , combined odor trap with sealing water and mechanical odor barrier (absolutely odor-tight even without water). Backflow-proof up to 50 cm accumulation height.
Additional Information	incl. Removable trap inlet, adjustable fixing angles, hair catcher, lot cover and protection cover
Installation	HL542Prblue Liquid shower and floor drain for coated floor coverings, with adjustable stainless-steel frame (from 1 to 7 mm) for adaption to the final surface height. Sealing set with fleece covered foil (HL542Prblue) to apply the waterproofing and a stainless steel flange for a secure connection to the floor coating material. Incl. Primus blue trap, Combined cover, extension rings and protection cover. Please also see installation movie and the function of Primus blue at www.hl.at

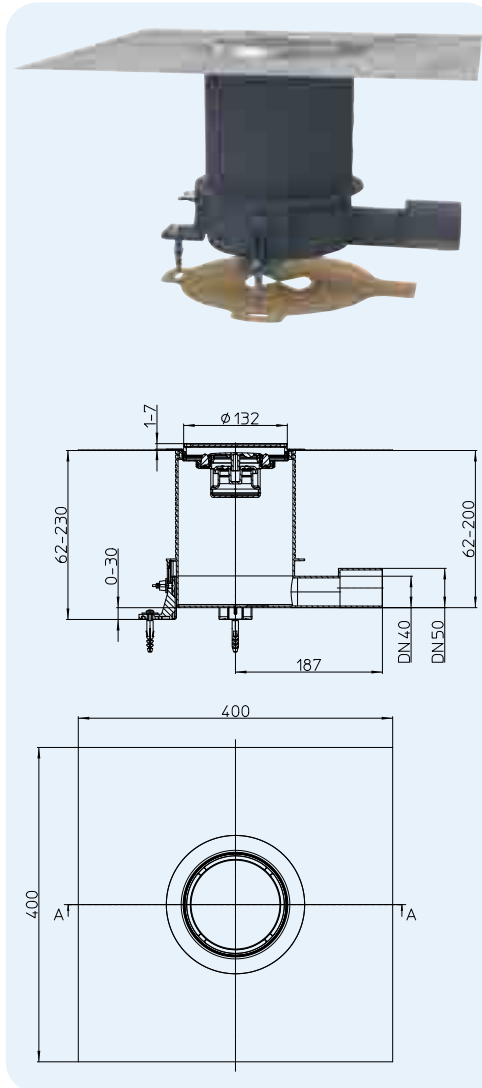

HL542Prblue

HL542Prblue.0



HL541K



HL-Nr.	Dimension	Cover	Weight	EAN	Pcs / package
542Prblue	DN40/50	Stainless steel V4A	1313 g	+050154	1
542Prblue.0	DN40/50	Stainless steel V4A	1238 g	+052622	1

HL0542.1E, HL0542.7E Design grates

Data

Material	Stainless steel V4A
Grate	Stainless steel grate Ø 129 mm
Load classification	HL0542.1E: K3 – max. 300 kg HL0542.7E : L15 – max. 1,5 t
Recommended for	HL542Prblue and HL542Prblue.0
Additional Information	HL0542.1E Combined cover (can be used on both sides - one side with 1.5 mm deep coating mould for individual coating, the reverse side with polished surface)

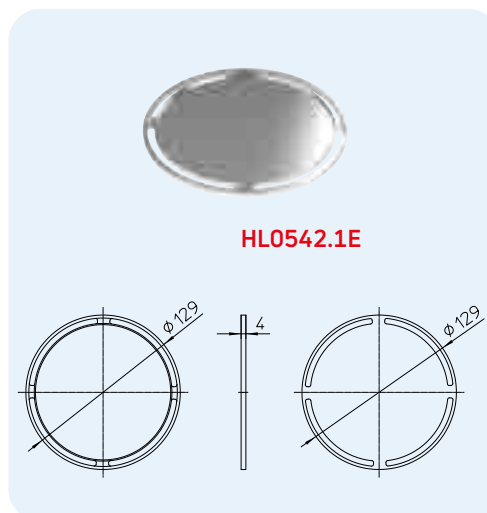

HL0542.1E

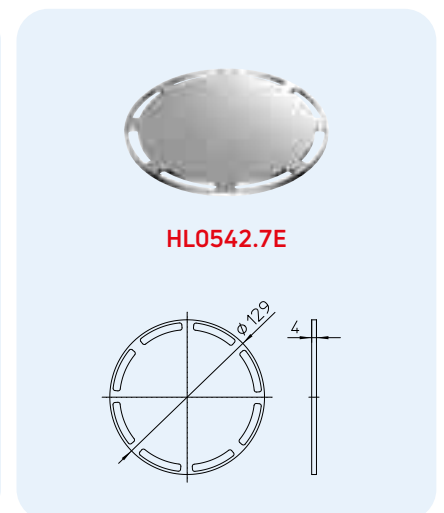

HL0542.7E

HL-Nr.	Material	Dimension	Weight	EAN	Pcs / package
0542.1E	Stainless steel V4A	Ø 129 mm	x g	+002245x	1
0542.7E	Stainless steel V4A	Ø 129 mm	x g	+001934x	1



SIPHONS ABLÄUFE



480

28

160



100

235

100

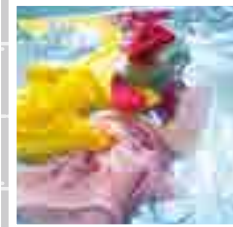

193



214

HL Siphons

6. Washing devices

6



HL Traps for washing devices – Products – Overview

Siphons



Product	HL400	HL404.1	HL4000.0/1/.2	HL405	HL405E	HL405ECO
Description	Standard concealed washing device trap	Concealed washing device trap with ventpipe	Washing device siphon corpus with single or double cartridge	Concealed washing device trap with water supply set	Concealed washing device trap with water supply set and power socket	Concealed washing device trap with water supply set
Function	For siphoning of washing machines, dishwashers a.s.o. with integrated backwater valve	For siphoning of washing machines, dishwashers a.s.o. with integrated backwater valve and ventpipe; for connections, which are more away than 4m from the downpipe	Washing device siphon with removable siphon cartridge, either for single or double connection (e.g. washing machine + clothes dryer)	For siphoning of washing machines, dishwashers a.s.o. with integrated cold water supply	For siphoning of washing machines, dishwashers a.s.o. with integrated cold water supply and power socket	For siphoning of washing machines, dishwashers a.s.o. with prepared cold water supply for a tap of your choice

Basic information about design and installation

In principle all washing devices should be connected by it's on trap to the sewage pipe. HL supplies a wide range of different traps and combination possibilities.

▲ Siphoning

Different to the normal siphoning of washbasins or sinks, one uses for washing devices concealed traps. This has a lot of advantages: saves space, nice design and minimizes the sound of flowing water.

▲ Maintenance and cleaning

All HL concealed washing device traps have a cleaning eye. HL4000-series: The siphon cartridge may be removed for cleaning or maintenance reasons. Easy function control with a transparent backside. Easy access to the downpipe for cleaning reasons.

▲ Waterproofness

By using O-rings between trap and hose connector, the highest watertightness is guaranteed, even when the nut is not yet fixed. Very important, as the outflowing water causes vibrations, which could release the connection.

▲ Installation

Please take care of installing the trap vertically. The red lot cover avoids the cleaning eye of getting dirty during construction. Should the trap be installed too much inside the wall, it is possible, to elongate the thread by a fitting spare-part. HL4000-series: By installing only the corpus HL4000.0 during the construction phase, the enduser can complete the siphon either with a single or a double cartridge (HL4000.1 or HL4000.2)

▲ With long access pipes it could be, that the water in the trap is sucked out, caused by too little air ventilation. This could be avoided from the beginning by using traps with integrated ventpipes. Beside of that HL supplies a lot of different combinations with additional power supply or cold water feed, for convenience and design reasons.

▲ Double connections

With HL4000-series it is possible for the house owner, to choose between a single or a double connection or to upgrade from single to double (e.g. washing machine + clothes dryer), when the corpus HL4000.0 is installed at first. The

double siphon cartridge has two hydraulically independent siphon chambers, which cares for highest safety. Backflow balls prevent the overflow from one device to the other.

Relevant standards/directives
 EN 12056 Gravity drainage systems for buildings and estates
 DIN 19541 Siphons for special purposes
 DIN 1988 Technical rules for cold water installation

HL Traps for washing devices – Products – Overview

Siphons

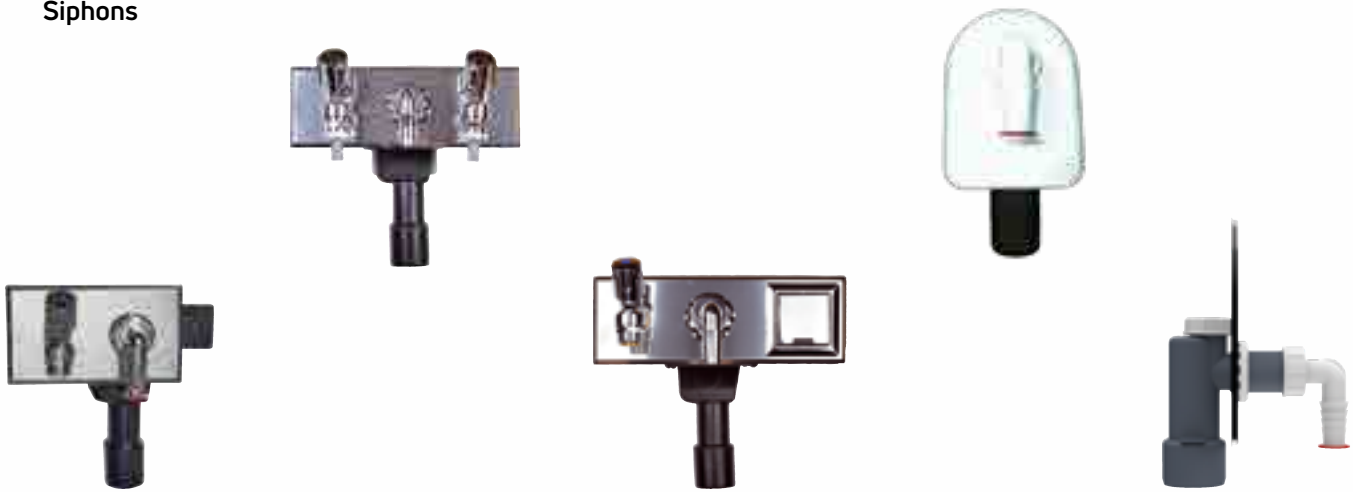

HL406	HL406.2	HL406E	HL410	HL440
Concealed washing device trap with water supply set	Concealed washing device trap with water supply set	Concealed washing device trap with power socket	Washing device trap	Concealed washing device trap with mechanical valve
For siphoning of washing machines, dishwashers a.s.o. with integrated cold water supply, hose connector with backwater valve and ventpipe	For siphoning of washing machines, dishwashers a.s.o. with integrated cold water supply, 2 hose connectors with backwater valve and ventpipe	For siphoning of washing machines, dishwashers a.s.o. with integrated cold water supply, hose connector with backwater valve, ventpipe and power socket	For siphoning of washing machines, dishwashers a.s.o., installation on the wall	For siphoning of washing machines, dishwashers a.s.o., little depth

Accessories



Product	HL2, HL2.2	HL2.1	HL19	HL19.2	HL420	HL421
Description	Washing device double hose connector with backwater valve	Washing device hose connector with backwater valve and ventpipe	Angled hose connector	Angled hose connector	Elongation for the thread	Elongation for the thread
Function	For connecting two washing machines or a washing machine and dryer to one trap. Should only be used as a problem solver.	Avoids, that the tube of the washing machine is sucked out	Connection between trap and the tube of the washing device	Connection between trap and the thin tube 8 - 13 mm	Elongation of the thread	Elongation of the thread, only usable, if the original thread was not yet cut!

HL Traps for washing devices – Installation instruction HL4000



1. Define position and fix the corpus



2. Connect to the pipe



3. Cut the protection cover alongside the wall



4. Choose between single (HL4000.1) or double (HL4000.2) siphon cartridge

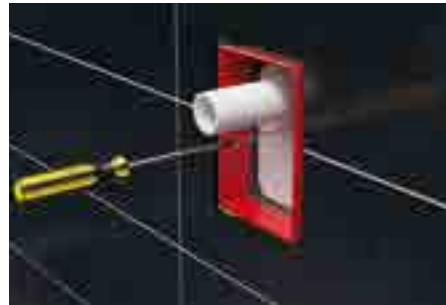

5. Insert cartridge and fix by screwing



6. Mark 3cm, measured from the wall (tile)



7. Cut at the mark

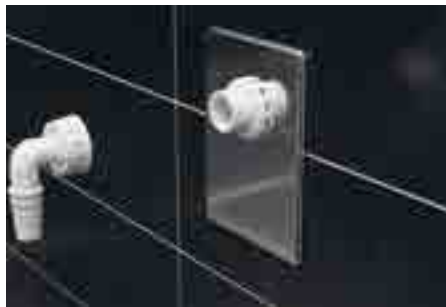

8. Set the cover and fix by thread ring, screw the hose nozzle.



9. Connect to the washing device



10. When installing a second washing device (or dryer), replace the single cartridge to a double.



11. Install cover, thread ring and hose nozzle.



12. Connect clothes dryer.

HL Traps for washing devices – Products – Data

HL400 Concealed washing device trap

Data

Capacity	0,38 l/s
Material	PE/Stainless steel
Connection dimension	1"
Outlet dimension	DN40/50
Standard	DIN 19541
Height of seal water	50 mm
Recommended for	Concealed siphoning of washing devices
Additional information	with stainless steel cover, cuttable red spacer, cleaning eye and back-water valve

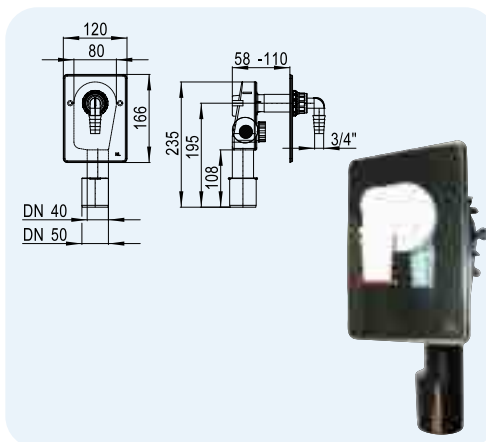

HL-No.	Dimension	Weight	EAN	Piece/package
400	DN40/50	280 g	+504008	10

HL404 Concealed washing device trap with option for connecting a ventpipe

Data

Capacity	0,38 l/s
Material	PE/Stainless steel
Connection dimension	1"
Outlet dimension	DN40/50
Standard	DIN 19541
Height of seal water	50 mm
Recommended for	Siphoning of washing devices, with option of ventpipe
Additional information	with chrome-plated cover, cuttable red spacer, cleaning eye and back-water valve

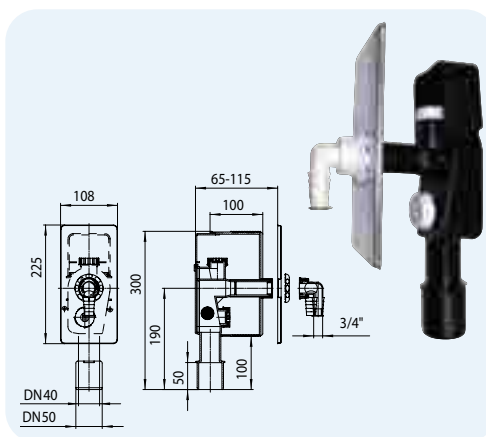

HL-No.	Dimension	Weight	EAN	Piece/package
404	DN40/50	484 g	+504046	5

HL404.1 Concealed washing device trap with integrated ventpipe

Data

Capacity	0,38 l/s
Material	PE/Stainless steel
Connection dimension	1"
Outlet dimension	DN40/50
Standard	DIN 19541
Height of seal water	50 mm
Recommended for	Siphoning of washing devices, with integrated ventpipe
Additional information	with chrome-plated cover, cuttable red spacer, cleaning eye and back-water valve

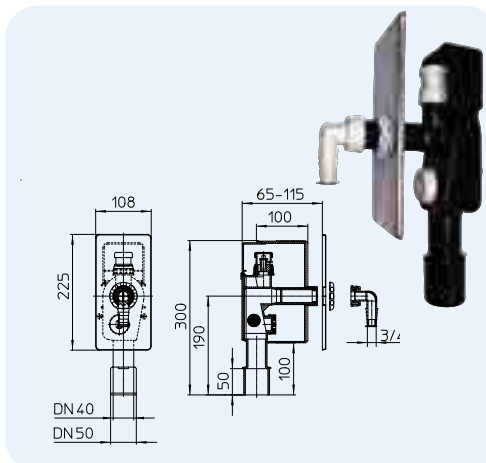

HL-No.	Dimension	Weight	EAN	Piece/package
404.1	DN40/50	504 g	+504145	5

HL4000.0 Washing device siphon - corpus

Data

Capacity	see HL4000.1 or HL4000.2
Material	PP
Outlet	DN40/50
Standard	DIN 19541
Recommended for	HL4000.1 for 1 washing device HL4000.2 for 2 washing devices
Additional information	After removing the cartridge there is a free access to the waste pipe Also see installation movie (www.hl.at)

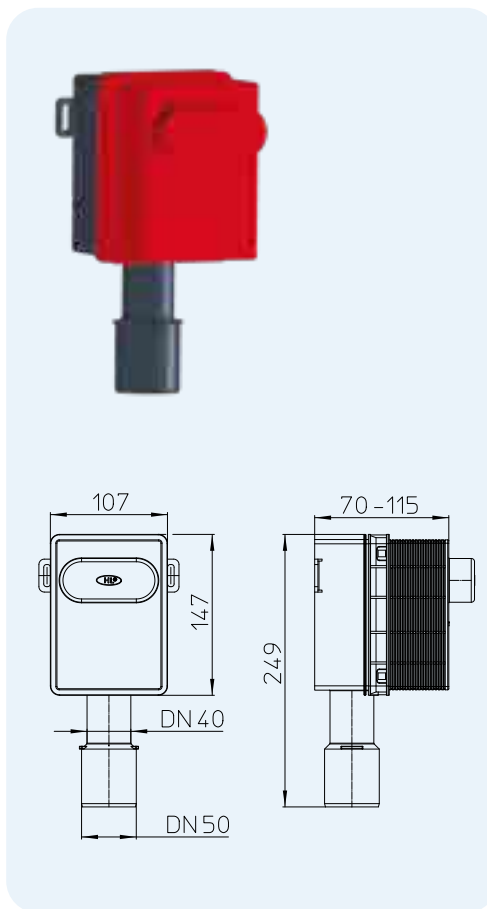

HL4000.0



HL-No.	Dimension	Weight	EAN	Piece/package
4000.0	DN40/50	244 g	+041619	10

HL4000.1 „Single-Upgrade-kit“ for washing device siphon HL4000.0 corpus HL4000.2 „Double-Upgrade-kit“ for HL4000.0 corpus (e.g. washing machine and clothes dryer)

Data

Capacity	HL4000.0 + HL4000.1: 0,5l/s HL4000.0 + HL4000.2: each 0,5l/s
Material	PP
Connection	HL4000.1: HL19 HL4000.2: 2x HL19 + 1x HL19.2
Standard	DIN 19541
Water trap	50 mm
Recommended for	Single cartridge for 1 washing machine Double cartridge for 1 washing machine + 1 clothes dryer
Additional information	with transparent backside for quick function control with integrated backflow balls Please also see installation movie (www.hl.at)

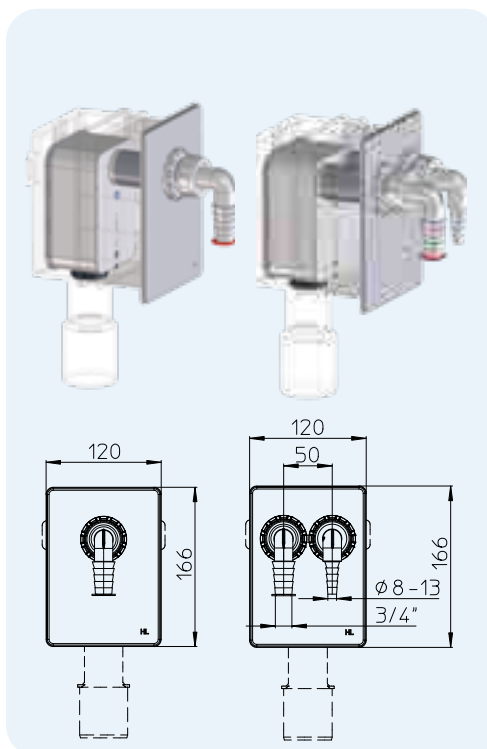

HL4000.1

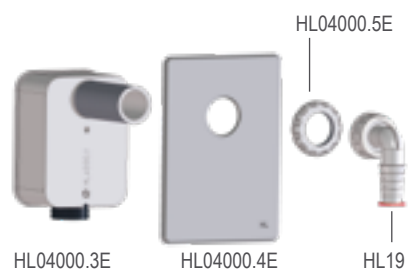

HL4000.2

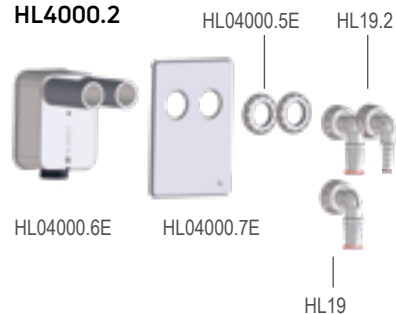

HL-No.	Dimension	Weight	EAN	Piece/package
4000.1	-	265 g	+041633	1
4000.2	-	350 g	+041640	1

HL405 Concealed washing device trap with integrated cold water supply

Data

Capacity	0,38 l/s
Material	PE/Stainless steel/MS
Connection dimension	1" / 1/2"
Outlet dimension	DN40/50
Standard	DIN 19541, DIN 1988
Height of seal water	50 mm
Recommended for	Siphoning of washing devices, connection of cold water line
Additional information	with chrome-plated cover, cuttable red spacer, 1/2" MS on/off valve and backing plate

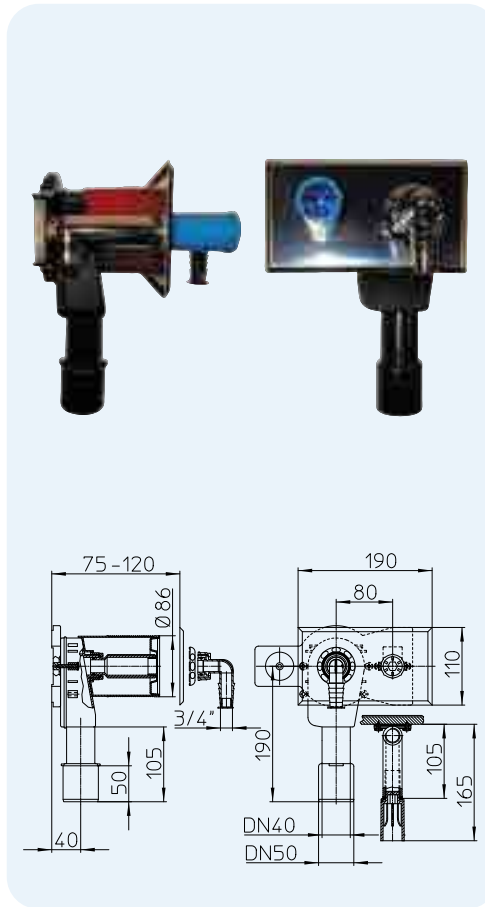

HL-No.	Dimension	Weight	EAN	Piece/package
405	DN40/50	973 g	+504053	1

HL405E Concealed washing device trap with integrated cold water supply and power socket

Data

Capacity	0,38 l/s
Material	PE/Stainless steel/MS
Connection dimension	1" / 1/2"
Outlet dimension	DN40/50
Standard	DIN 19541, DIN 1988
Height of seal water	50 mm
Recommended for	Siphoning of washing devices, connection of cold water line and power supply
Additional information	with chrome-plated cover, cuttable red spacer, 1/2" MS on/off valve and backing plate

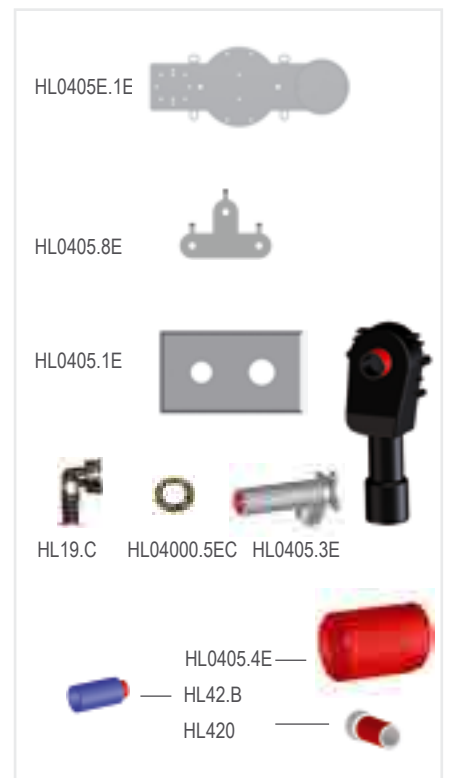
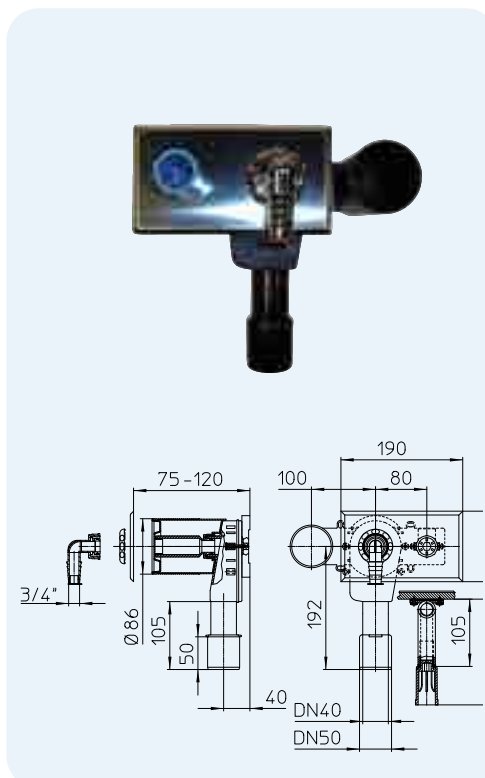

HL-No.	Dimension	Weight	EAN	Piece/package
405E	DN40/50	1000 g	+504091	1

HL405ECO Concealed washing device trap, prepared for individual cold water supply

Data

Capacity	0,38 l/s
Material	PE/Stainless steel
Connection dimension	1"
Outlet dimension	DN40/50
Standard	DIN 19541, DIN 1988
Height of seal water	50 mm
Recommended for	Siphoning of washing devices, prepared for cold water supply
Additional information	with chrome-plated cover, cuttable red spacer and backing plate

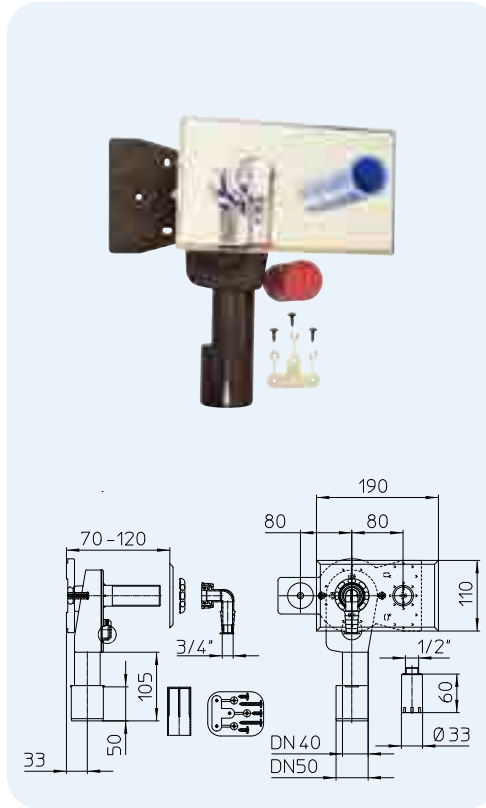

HL-No.	Dimension	Weight	EAN	Piece/package
405ECO	DN40/50	443 g	+015672	5

HL406 Concealed washing device trap with integrated cold water supply and on/off valve

Data

Capacity	0,38 l/s
Material	PE/Stainless steel/MS
Connection dimension	1" / 3/4"
Outlet dimension	DN40/50
Standard	DIN 19541, DIN 1988
Height of seal water	50 mm
Recommended for	Siphoning of washing devices, connection of cold water line
Additional information	with chrome-plated cover, cuttable red spacer, 1/2" MS on/off valve, backing plate and hose connector

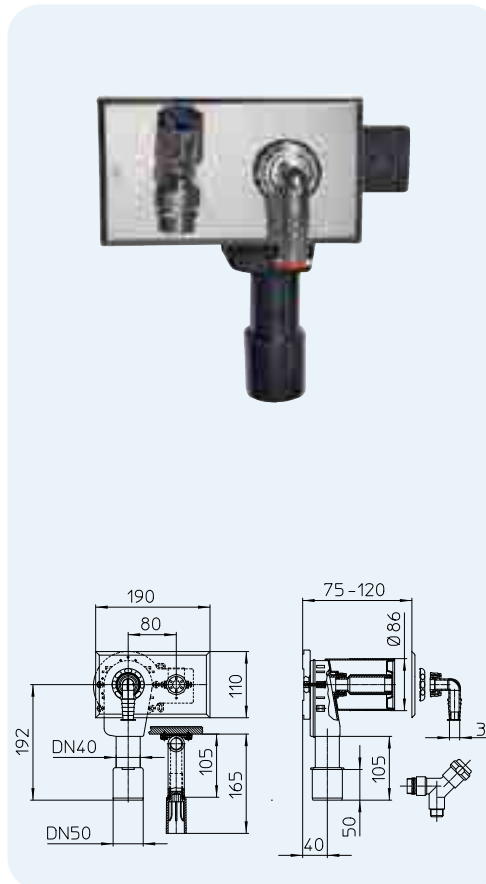

HL-No.	Dimension	Weight	EAN	Piece/package
406	DN40/50	1075 g	+504060	1

HL406.2 Concealed washing device trap with double water supply and double on/off valve
Data

Capacity	0,38 l/s
Material	PE/Stainless steel/MS
Connection dimension	1" / 2 x 3/4"
Outlet dimension	DN40/50
Standard	DIN 19541, DIN 1988
Height of seal water	50 mm
Recommended for	Siphoning of washing devices, connection of cold and warm water, e.g. at energy saving washing machines
Additional information	with chrome-plated cover, cuttable red spacer, 2 x 1/2" MS valve, backing plate and hose connector

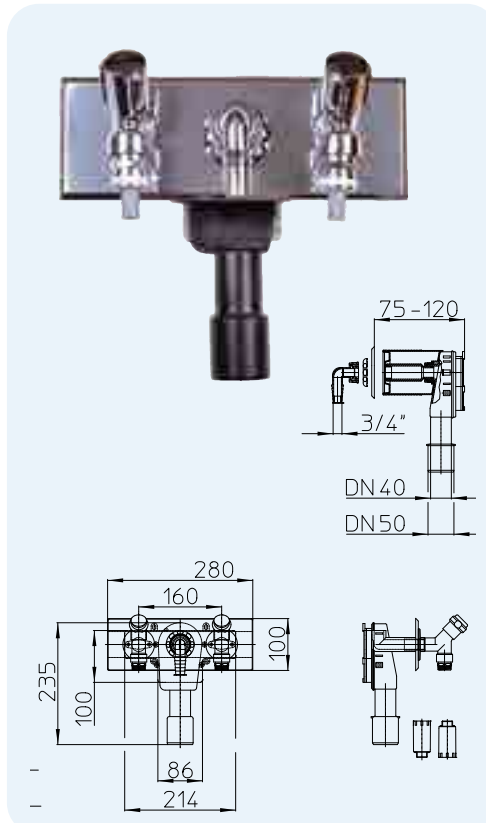

HL-No.	Dimension	Weight	EAN	Piece/package
406.2	DN40/50	1931 g	+008247	1

HL406E Concealed washing device trap with water supply, on/off valve and power supply
Data

Capacity	0,38 l/s
Material	PE/Stainless steel/MS
Connection dimension	1" / 3/4"
Outlet dimension	DN40/50
Standard	DIN 19541, DIN 1988
Height of seal water	50 mm
Recommended for	Siphoning of washing devices, connection of cold water line and power supply
Additional information	with chrome-plated cover, cuttable red spacer, 2 x 1/2" MS valve, backing plate and hose connector

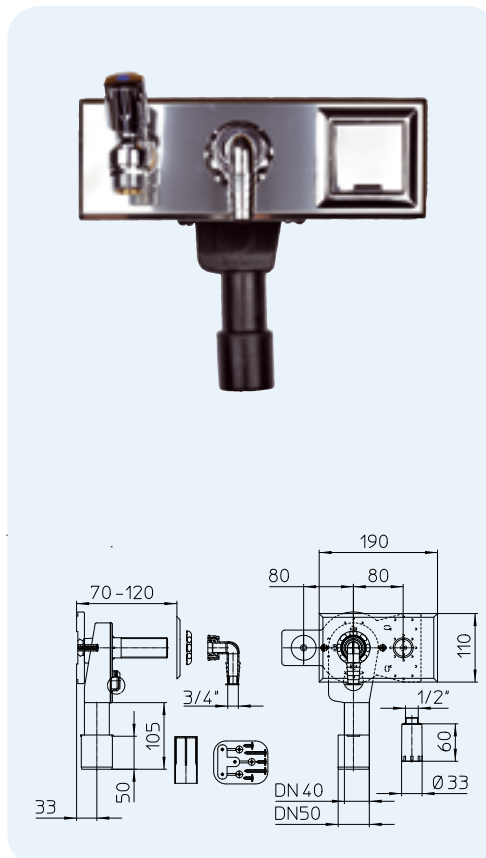

HL-No.	Dimension	Weight	EAN	Piece/package
406E	DN40/50	1310 g	+504077	1

HL410 Washing device trap

Data

Capacity	0,38 l/s
Material	PE
Connection dim.	1"
Outlet dimension	DN40
Standard	DIN 19541
Height of seal water	50 mm
Recommended for	Siphoning of washing devices, installed on the wall
Additional information	with white cover plate and fixing set

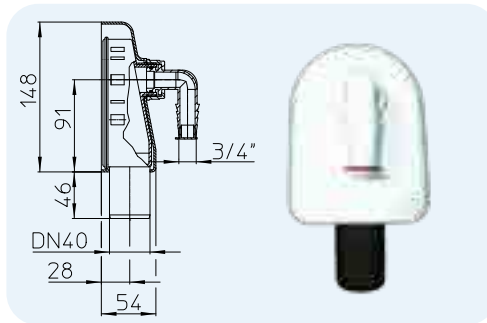

HL-No.	Dimension	Weight	EAN	Piece/package
410	DN40	440 g	+504107	5

HL440 Concealed washing device trap with mechanical valve

Data

Capacity	0,33 l/s
Material	PP
Connection dimension	1"
Outlet dimension	DN40/50
Standard	DIN 19541
Height of seal water	mechanical ball-trap
Recommended for	Siphoning of washing devices, little depth
Additional information	with chrome-plated cover

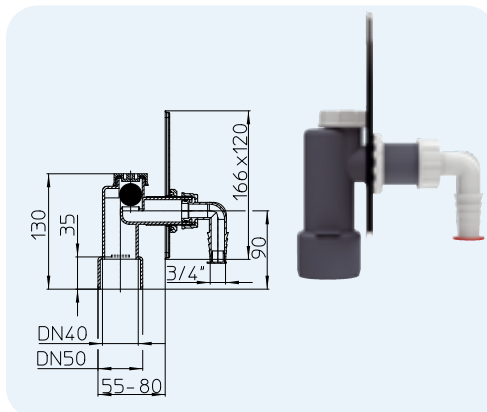

HL-No.	Dimension	Weight	EAN	Piece/package
440	DN40/50	200 g	+504404	20

HL Traps for washing devices – Products – Accessories

HL2 Double hose connector with backwater valve

Data

Capacity	1 connector 0,28 l/s 2 connectors each 0,23 l/s
Material	PP
Connection dimension	2 x 3/4"
Outlet dimension	1"
Recommended for	Problem-solver
Additional information	with integrated backwater valves

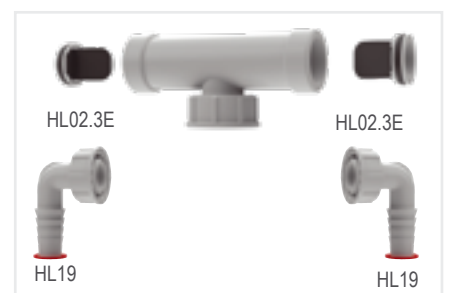
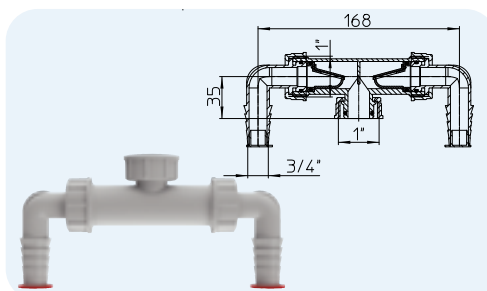

HL-No.	Dimension	Weight	EAN	Piece/package
2	1" x 3/4"	85 g	+520022	10

HL2.0 Double hose connector with backwater valve, with flat gasket

Data

Capacity	1 connector 0,28 l/s 2 connectors each 0,23 l/s
Material	PP
Connection dimension	2 x 3/4"
Outlet dimension	1" with flat gasket
Recommended for	Problem-solver
Additional information	with integrated backwater valves

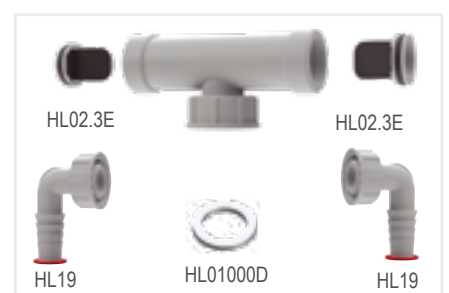
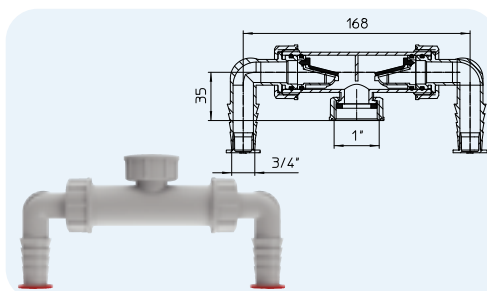

HL-No.	Dimension	Weight	EAN	Piece/package
2.0	1" x 3/4"	80 g	+530021	1

HL2.1 Hose connector with backwater valve and ventpipe

Data

Capacity	0,28 l/s
Material	PP
Connection dimension	3/4"
Outlet dimension	1"
Recommended for	Prevents the trap from being sucked out
Additional information	with integrated backwater valve and ventpipe

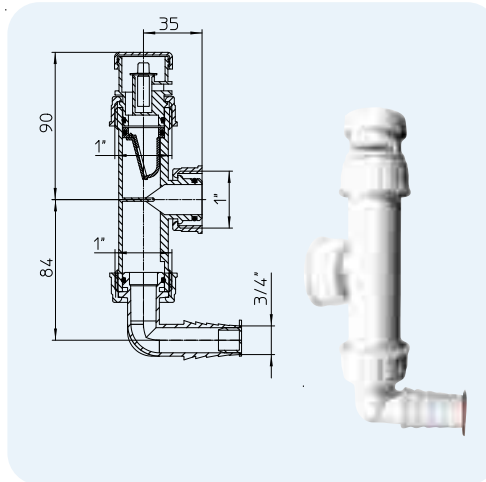

HL-No.	Dimension	Weight	EAN	Piece/package
2.1	1" x 3/4"	65 g	+5320213	1

HL2.2 Double hose connector with backwater valve

Data

Capacity	0,14 l/s
Material	PP
Connection dimension	1 x 3/4"
	1 x Ø 8-13mm
Outlet dimension	1"
Recommended for	Problem-solver
Additional information	with integrated backwater valves

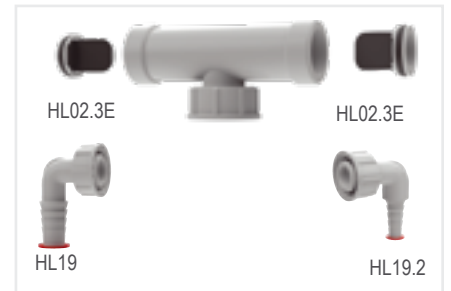
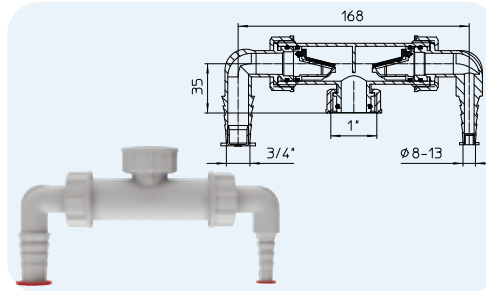

HL-No.	Dimension	Weight	EAN	Piece/package
2.2	1 x 3/4" & 1 x Ø 8-13mm	85 g	+002283	10

HL17 General connector

Data

Material	PP
Connection dimension	3/4"
Outlet dimension	6/4"/DN40
Recommended for	Junction from tube to plug or screw connection

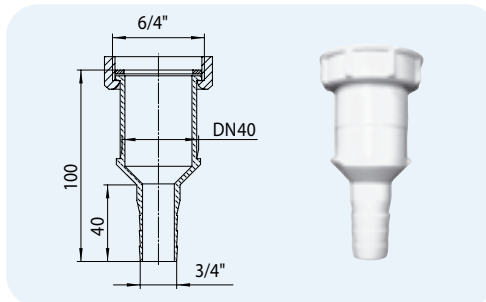

HL-No.	Dimension	Weight	EAN	Piece/package
17	6/4" x DN40 x 3/4"	35 g	+500178	1

HL18 General hose connector

Data

Material	PP
Connection dimension	3/4"
Outlet dimension	6/4"
Recommended for	Junction from tube to screw connection

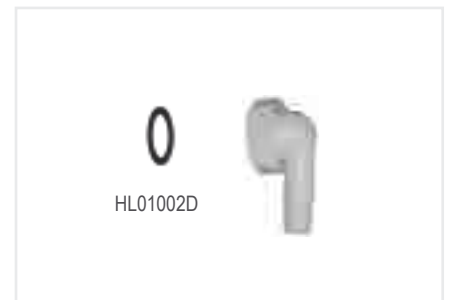
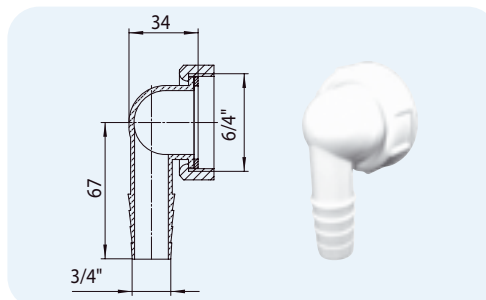

HL-No.	Dimension	Weight	EAN	Piece/package
18	6/4" x 3/4"	25 g	+500185	1

HL19... Hose connector

Data

Material	PP
Connection dimension	HL19, HL19.0, HL19.C: 3/4" HL19.2: Ø 8 – 13 mm
Outlet dimension	1"
Recommended for	Connection of tubes of washing devices
Additional information	Gasket = O-ring, except HL19.0

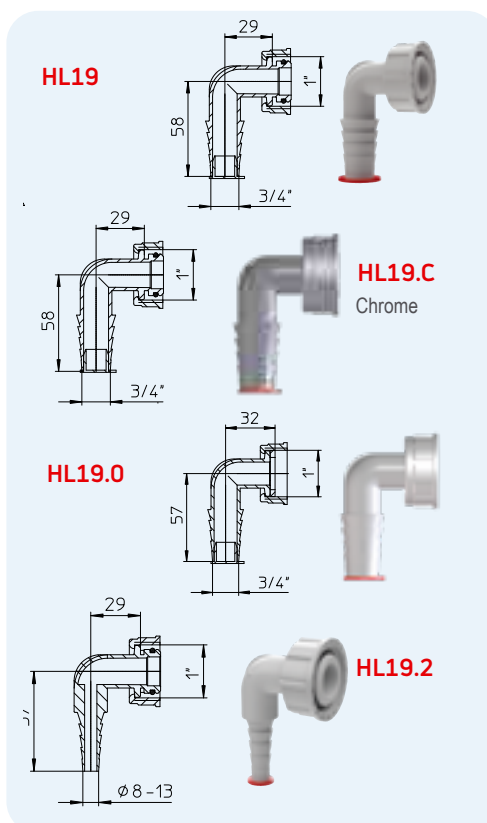

HL-No.	Dimension	Weight	EAN	Piece/package
19	1" x 3/4"	18 g	+100194	10
19.C	1" x 3/4"	18 g	+190041	1
19.0	1" x 3/4"	18 g	+112197	1
19.2	1" x 8 – 13 mm	15 g	+001927	1

HL405B Backing plate

Data

Material	Galvanized steel
Recommended for	fits to HL44, HL405(E)(ECO) and HL406(E)(.2)

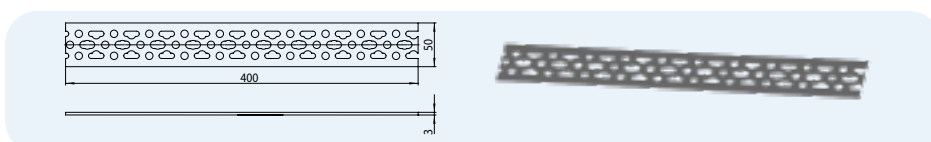

HL-No.	Dimension	Weight	EAN	Piece/package
405B	50 x 400 mm	965 g	+504084	1

HL420 Extension for the thread

Data

Material	PP
Connection dimension	1"
Outlet dimension	1"
Recommended for	Elongation of the thread for all HL washing device traps

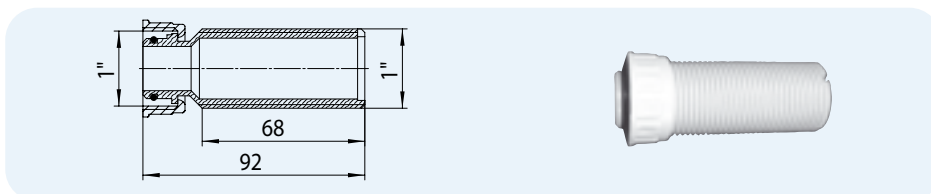

HL-No.	Dimension	Weight	EAN	Piece/package
420	1"	20 g	+504206	1

HL421 Pushfit extension for the thread

Data

Material	PP
Connection dimension	1"
Recommended for	Stepless junction for the thread for all HL washing device traps, except HL406, HL406.2, HL406E, HL410, HL440

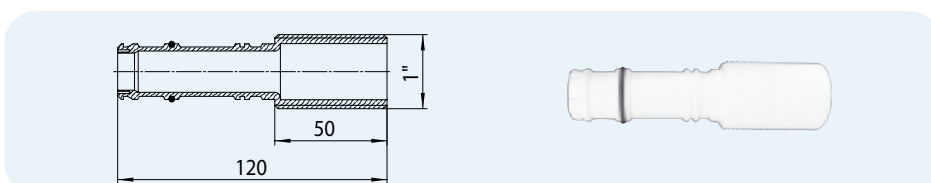

HL-No.	Dimension	Weight	EAN	Piece/package
421	1"	25 g	+421008	1



SIPHONS ABLÄUFE



HL Siphons

107. Air condition and ventilation

7

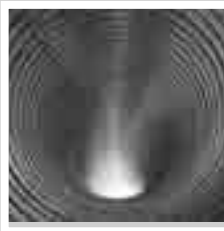
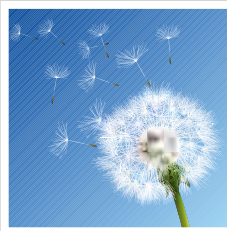

HL Stench traps for air condition and ventilation

Basic information about design and installation

Mostly the connection of condensate water or dripping water to the waste water system is forgotten, when planning. A proper waste water draw-off is mostly left to the creativity of the plumber - and therefore very prone to error. At the same time different problems occur, when you drain little quantities of liquids, which may be solved already in advance during planning. Hereafter we like to offer you some proposals:

▲ Self-cleaning

Drains, which are used for little quantities of liquid (condensate water, dripping water of heating systems or boilers) are difficult just because the little flow velocity - because there is no self-cleaning effect in the siphon. Therefore it makes sense, to care for a sufficient diameter of the sewage pipe; Minimum: DN32. Beside of that we recommend to install horizontal pipes in direction to the siphon with a minimum incline of 10%.

▲ Stench trap

When the connected device is not working for a longer time, the seal water might evaporate. Therefore please take care, that you have enough height of seal water inside the trap (HL136.2) or to have an additional mechanical trap inside (HL136T, HL136T.3, HL138N, HL138NH and HL21).

▲ Maintenance/cleaning

With flush-mounted traps (only HL138NH!) please take care, that you have a constant access to the stench trap. The inspection intervals are depending on the kind and quantity of the fine dust in the air (with air conditioners minimum before start of the season in spring time).

▲ Pressure differences

With central air conditioners or ventilation facilities the trap has to be installed in that way, that on the one hand in case of vacuum no air from the surrounding room gets into the device, and on the other hand, that in case of overpressure no air escapes from the device.

HL136.2: Suitable for vacuum or overpressure up to 2800 pascal (28cm water column). This trap is equipped with transparent pipes to control the height of the seal water and with an additional hose nozzle for refilling.

HL136T and HL136T.3: These traps prevent air from getting into the device. Suitable for vacuum up to 1300 pascal (13cm water column), depending on the length of the immersion tube.

Relevant standards/directives

EN 12056..... Gravity drainage systems inside of buildings
 DIN 19541 Siphons for special purposes
 ÖNORM H 6020 Ventilating systems for medical used rooms - Development, construction, operation, maintenance, technical and hygienic supervision

HL Traps for air condition and ventilation – Products – Data

HL20 Drip funnel

Data

Material	PP
Connection dimension	170 x 92 mm
Outlet dimension	6/4"
Recommended for	the drainage of dripping water and sewage, which is not allowed to have a direct connection to the sewer
Additional information	including pipe clip, stench trap possible in combination with e.g. HL100

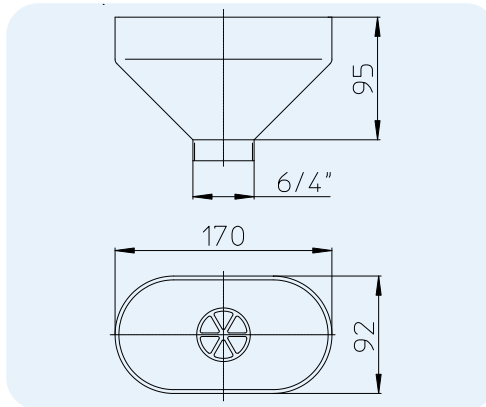

HL-No.	Dimension	Weight	EAN	Piece/package
20	6/4"	115 g	+500208	1

HL21 Drip funnel including trap

Data

Capacity	0,17 l/s
Material	PP
Connection dimension	92 x 55 mm
Outlet dimension	DN32
Stench trap	60mm seal water with additional mechanical ball trap
Standard	DIN 19541, EN 1451
Recommended for	Connections with inconstant water flow
Additional information	also odourless without seal water

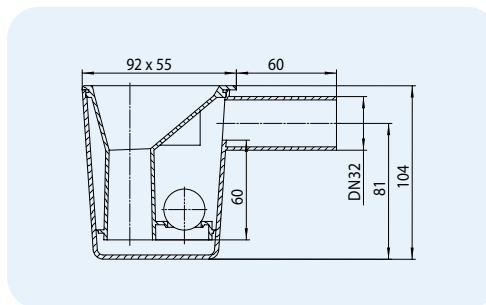

HL-No.	Dimension	Weight	EAN	Piece/package
21	DN32	90 g	+500215	1

HL136.2 Stench trap for condensate with seal water

Data

Material	PP
Connection dimension	DN40
Outlet dimension	DN40
Stench trap	280 mm seal water
Standard	DIN 19541
Recommended for	vacuum - or overpressure pipes (connection to suction- or discharge side)
Additional information	with average sealing water 2800 PA airtight on the suction or discharge side, with hoze nozzle for refilling

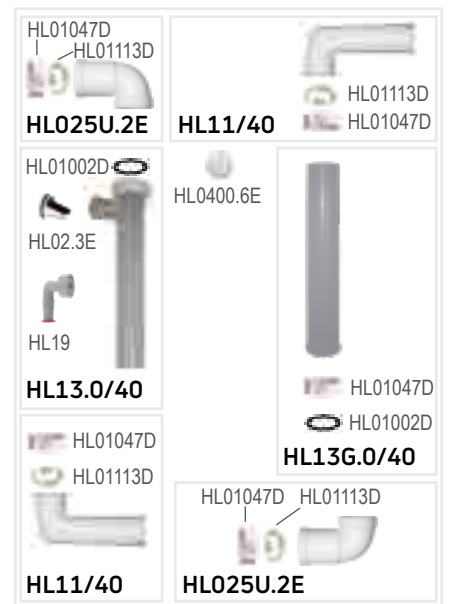
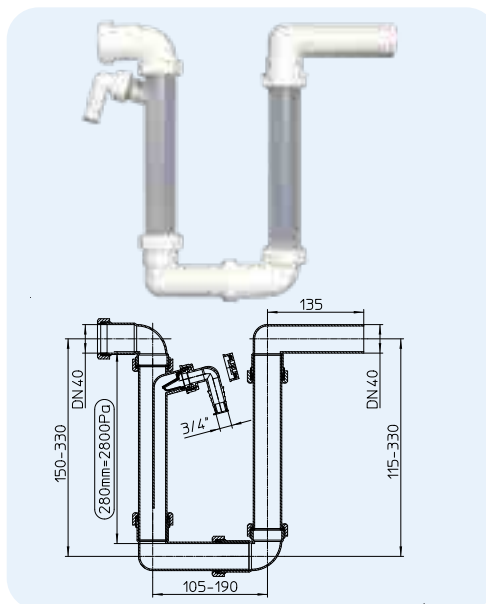

HL-No.	Dimension	Weight	EAN	Piece/package
136.2	DN40	364 g	+008223	10

HL136T Ball condensate trap DN40 transparent
Data

Capacity	0,42 l/s
Material	PP
Connection dimension	DN32 with locking nut Ø 12-18 mm for plugging
Outlet dimension	DN40
Stench trap	60mm seal water with additional mechanical ball trap
Standard	DIN 19541, EN 12056
Recommended for	Air conditioners, ventilation- and heating devices
Additional information	also odourless without seal water, possible inlet horizontal and vertical

-Pascal	H	L
< -300	30	80
(-300)-(-500)	30-50	80
(-500)-(-700)	50-70	100
(-700)-(-900)	70-90	120
(-900)-(-1100)	90-110	140
(-1100)-(-1300)	110-130	160

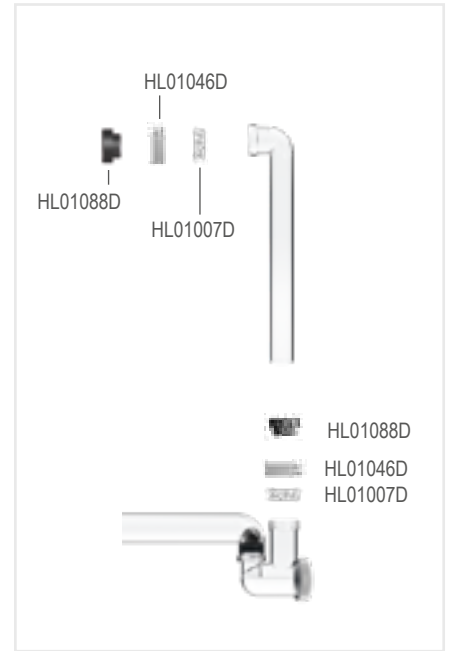
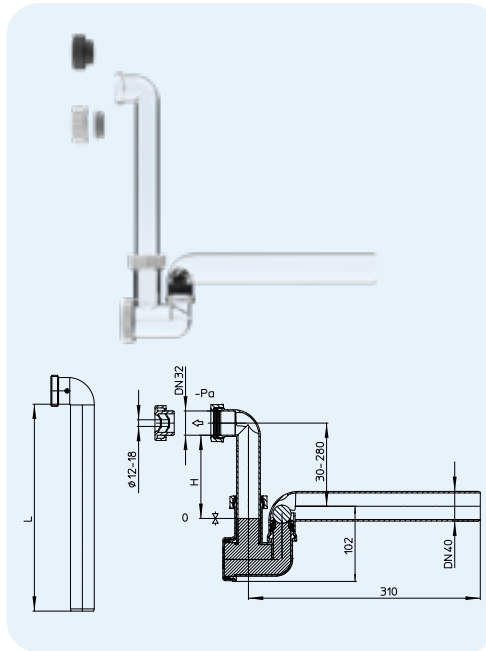

HL-No.	Dimension	Weight	EAN	Piece/package
136T	DN40 x DN32 or Ø 12 - 18 mm	235 g		10

HL136T.3 Ball condensate trap DN40 transparent
Data

Capacity	0,38 l/s
Material	PP
Connection dimension	5/4"
Outlet dimension	DN40
Stench trap	60mm seal water with additional mechanical ball trap
Standard	DIN 19541, EN 12056
Recommended for	Air conditioners, ventilation- and heating devices
Additional information	also odourless without seal water

-Pascal	H	L
< -300	30	80
(-300)-(-500)	30-50	80
(-500)-(-700)	50-70	100
(-700)-(-900)	70-90	120
(-900)-(-1100)	90-110	140
(-1100)-(-1300)	110-130	160

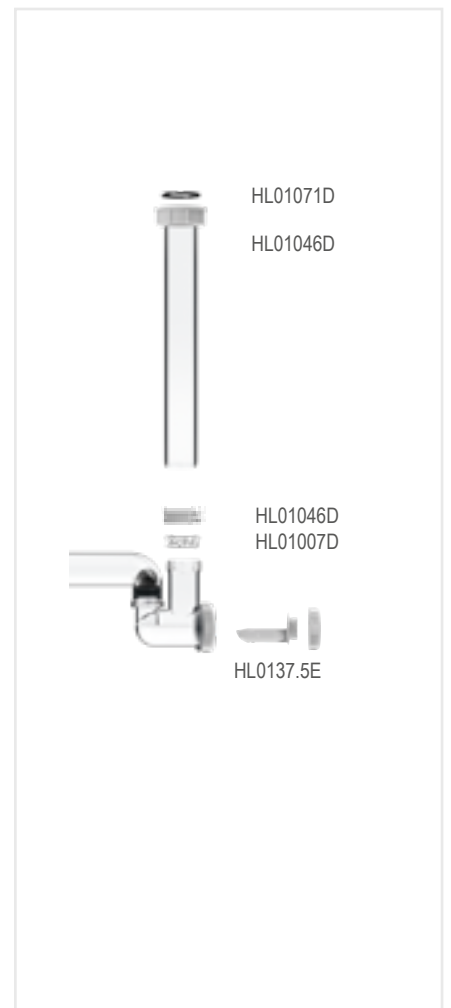
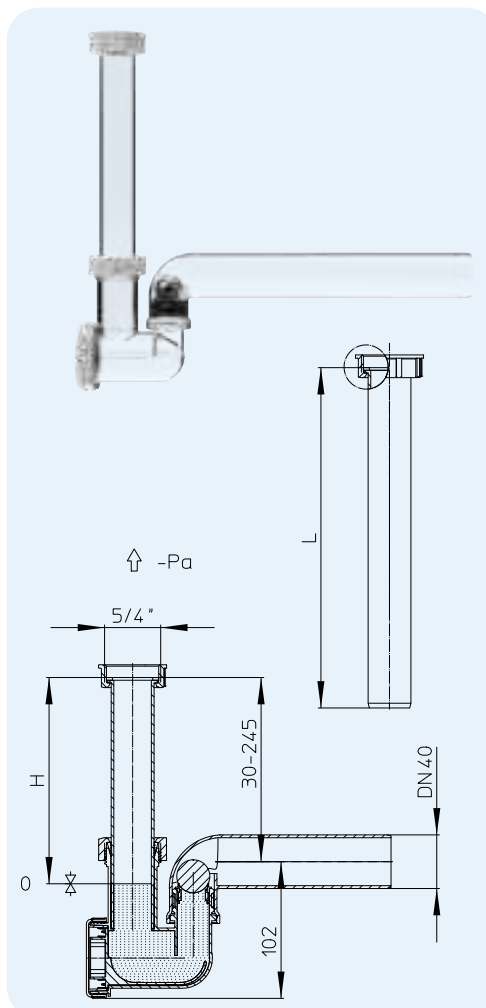

HL-No.	Dimension	Weight	EAN	Piece/package
136T.3	DN40 x 5/4"	235 g	+011889	10

HL138N Flush mounted stench trap for condensate
Data

Capacity	0,15 l/s
Material	PP
Connection dimension	For connecting pipes from $\varnothing 20 - 32$ mm and minimal inner dimension of a pipe $\varnothing 18$ mm
Outlet dimension	DN32
Stench trap	50 mm seal water, additional with ball as mechanical odour barrier
Standard	DIN 19541
Recommended for	Air conditioners, ventilation- and heating devices
Additional information	also odourless without seal water, removable siphon cartridge

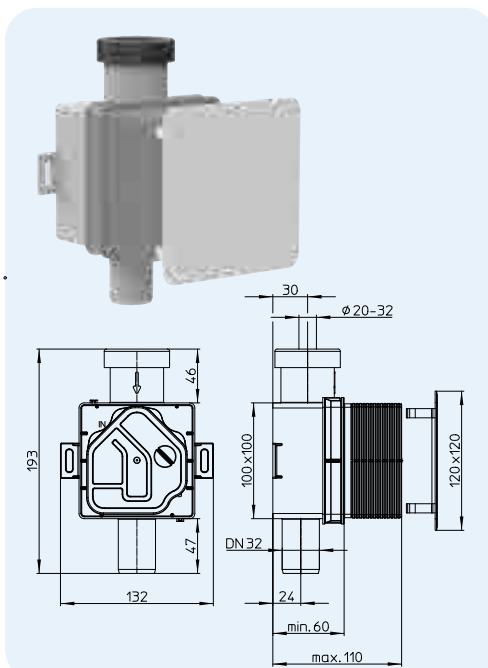
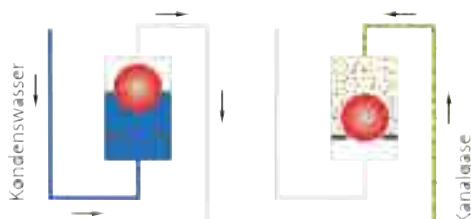

HL-No.	Dimension	Weight	EAN	Piece/package
138N	DN32 x $\varnothing 20 - 32$ mm	266 g	+051892	10

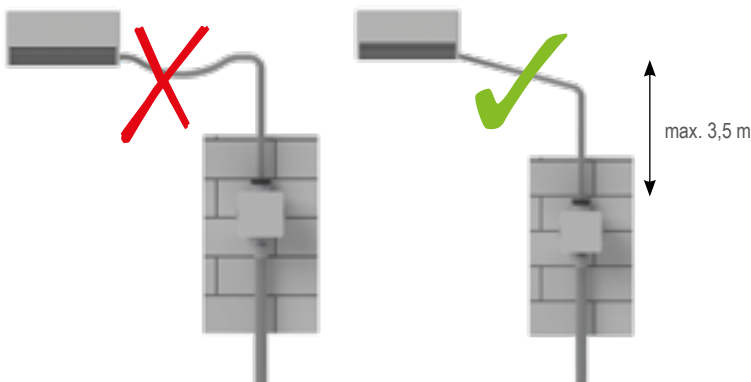
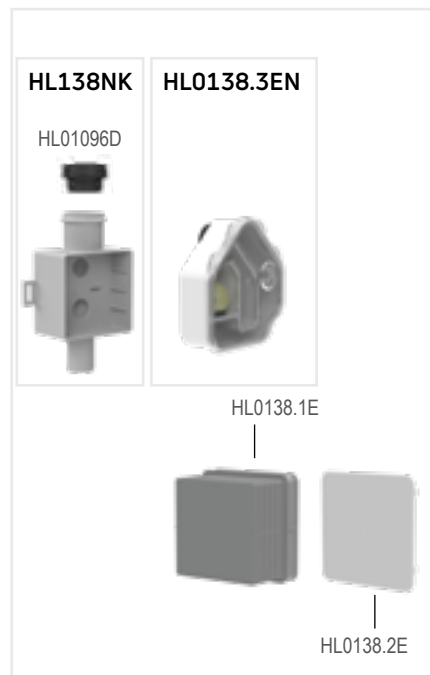
HL138NH Flush mounted stench trap for condensate with hygienic adapter
Data

Capacity	72 l/h
Material	PP
Connection	For connecting pipes from 20 - 32 mm and minimal inner pipe diameter 18mm
Outlet dimension	DN32
Stench trap	50 mm seal water, additional with ball as mechanical odour barrier
Standard	ÖNORM H 6020, VDI 6022, DIN 19541
Recommended for	drainage of condensate water of air conditioners, ventilation and heating devices, especially for e.g. hospitals, clinical institutions and care homes acc. ÖNORM H 6020
Additional information	also odourless without seal water; removable siphon cartridge; With Austian hygienic certificate (please see www.hl.at)

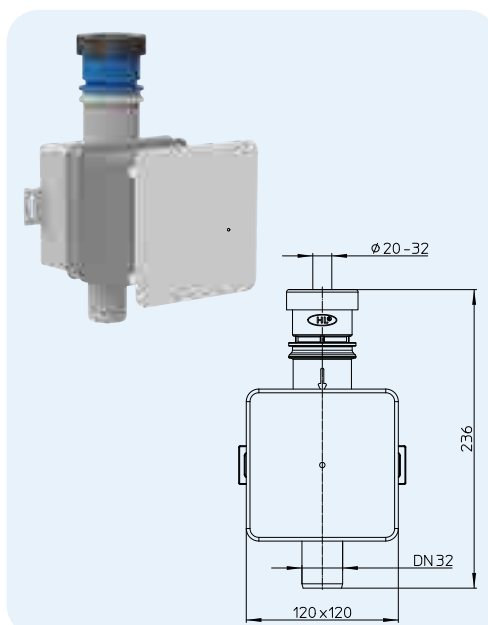

HL-No.	Dimension	Weight	EAN	Piece/package
138NH	DN32 x $\varnothing 20 - 32$ mm	286 g	000166	1

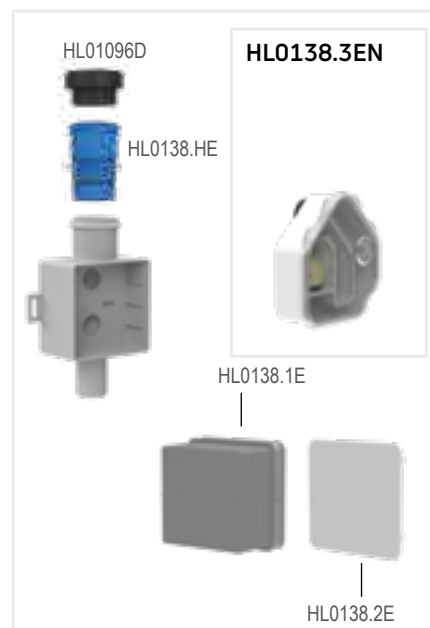



SIPHONS ABLÄUFE



230

350

120

Ø 102 ± 5



HL Connectors

8. Toilet

8



DN 110

HL Toilet connectors

Basic information about design and installation

HL supplies fitting connectors for every kind of toilet, which match with modern installation technology, functionally and visually. The plumber should take care on the following topics:

▲ Tightness

Please check the diameter of the outlet of the toilet facility, before connecting to the drainage system. As this connection is mostly behind the wall or in the floor, leakage in this area might be very unpleasant. Note: Outer diameter 102mm, tolerance +/- 5 mm.

▲ Flexibility

When installing a toilet on the floor, sometimes the problem occurs, that the position of the outlet pipe is imprecise. This may be solved by using excentric connectors or rosettes.

▲ Material

The usage of high-quality material guarantees a long lifetime. When leakiness occurs, the gasket easily may be changed.

Relevant standards/directives

DIN 19560 Pipes and fittings made of PP inside the building
DIN 1389 Toilet connection fittings

HL Toilet connectors – Products – Data

HL200 Toilet connector with excentric sleeve

Data

Material	PE-soft
Connection dimension	Ø 102 ± 5 mm
Outlet dimension	HL200/1: Ø 100 – 112 mm HL200/90: Ø 80 – 92 mm
Standard	DIN 1389
Recommended for	Toilet bowls with vertical outlet
Additional information	with multiple lip-seal, 20mm excentricity

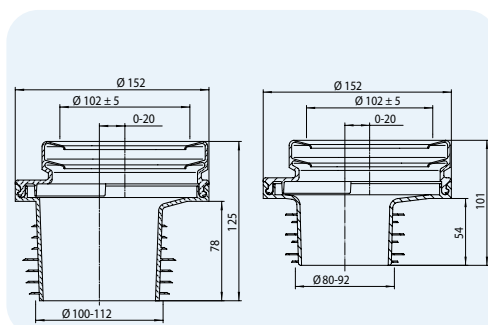

HL-No.	Dimension	Weight	EAN	Piece/package
200/1	DN110	225 g	+502004	10
200/90	DN90	220 g	+200900	10

HL201 Toilet connector

Data

Material	PE-soft
Connection dimension	Ø 102 ± 5 mm
Outlet dimension	Ø 100 – 112 mm
Standard	DIN 1389
Recommended for	Toilet bowls with vertical outlet
Additional information	with multiple lip seal

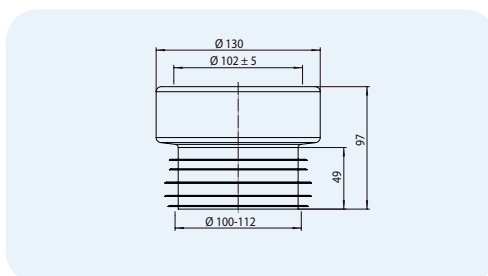

HL-No.	Dimension	Weight	EAN	Piece/package
201	DN110	110 g	+502011	10

HL202 Pan connector HL202G Toilet connector

Data

Material	PP
Connection dimension	HL202: $\varnothing 102 \pm 5$ mm/DN50 HL202G: $\varnothing 102 \pm 5$ mm
Outlet dimension	DN110
Standard	DIN 1389
Recommended for	Toilet bowls with vertical outlet
Additional information	with gasket

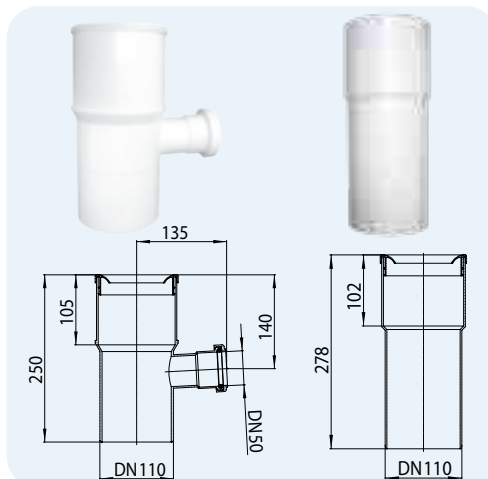

HL-No.	Dimension	Weight	EAN	Piece/package
202	DN100 x DN50	275 g	+502028	15
202G	DN110	275 g	+512027	15

HL203 Toilet connector white

Data

Material	PP
Connection dimension	$\varnothing 97 - 110$ mm
Outlet dimension	DN110
Standard	DIN 1389
Recommended for	Toilet bowls with horizontal outlet
Additional information	with flexible gasket and ring

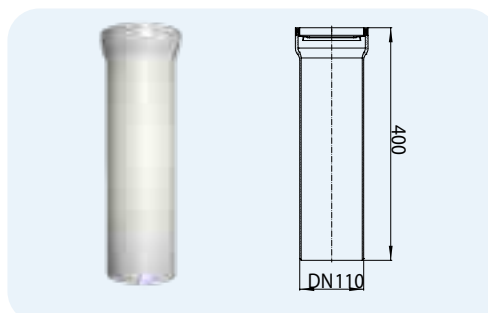

HL-No.	Dimension	Weight	EAN	Piece/package
203/1	DN110	215 g	+502035	10

HL203/90 Toilet connector white

Data

Material	PP
Connection dimension	$\varnothing 102 \pm 5$ mm
Outlet dimension	DN90
Standard	DIN 1389
Recommended for	Toilet bowls with horizontal outlet
Additional information	with gasket

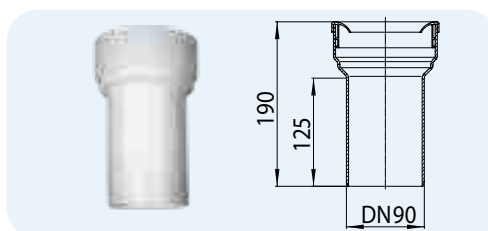

HL-No.	Dimension	Weight	EAN	Piece/package
203/90WE	DN90	190 g	+502134	25

HL204 Discharged toilet connector white

Data

Material	PP
Connection dimension	$\varnothing 97 - 110$ mm
Outlet dimension	DN110
Standard	DIN 1389
Recommended for	Toilet bowls with horizontal outlet
Additional information	15 mm discharged, with gasket and ring

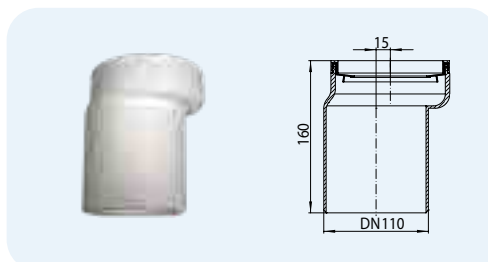

HL-No.	Dimension	Weight	EAN	Piece/package
204	DN110	220 g	+502042	1

HL205 Toilet elbow-connector, white
Data

Material	PP
Connection dimension	Ø 97 – 110 mm
Outlet dimension	DN110
Standard	DIN 1389
Recommended for	Toilet bowls with horizontal outlet
Additional information	with gasket and ring

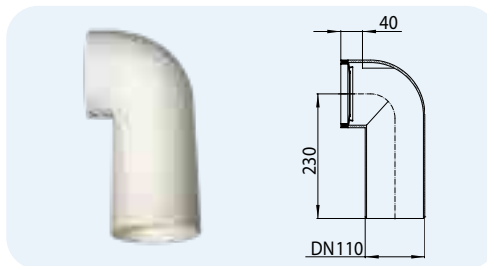

HL-No.	Dimension	Weight
205	DN110	220 g



EAN	Piece/package
+502059	10

HL209 Toilet elbow-connector, white with ball-joint
Data

Material	PP
Connection dimension	Ø 97 – 110 mm
Outlet dimension	DN90
Standard	DIN 1389
Recommended for	Toilet bowls with horizontal outlet
Additional information	with ball-joint, gasket and ring

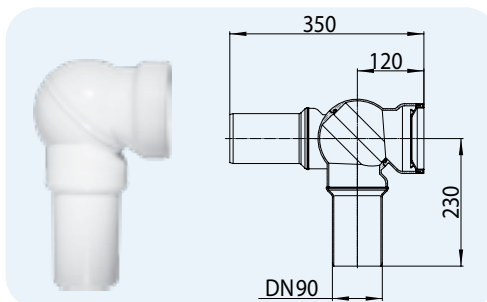

HL-No.	Dimension	Weight
209.WE	DN110 x DN90	405 g



EAN	Piece/package
+502097	10

HL210 Toilet elbow-connector, white with ball-joint
HL210P like HL210 but PVC DN100
Data

Material	HL210.WE: PP HL210P: PP/PVC
Connection dimension	Ø 97 – 110 mm
Outlet dimension	HL210.WE: DN110 HL210P: DN100
Standard	DIN 1389
Recommended for	Toilet bowls with horizontal outlet
Additional information	with ball-joint, gasket and ring, product "P": outlet made of PVC

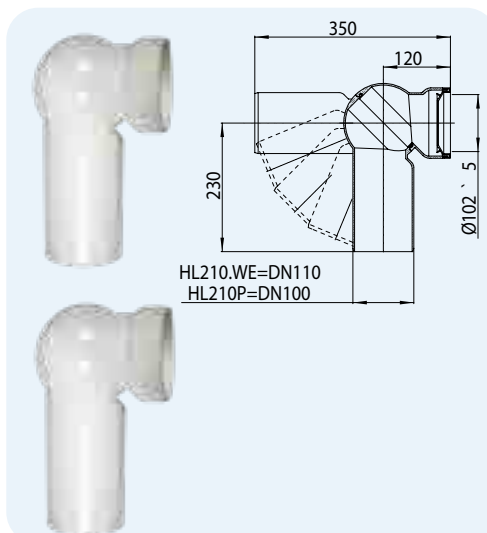

HL-No.	Dimension	Weight
210.WE	DN110	430 g
210P	DN100	540 g



EAN	Piece/package
+502103	10
+502110	1

HL210.7 Toilet elbow-connector, white with ball-joint and rosette
Data

Material	PP
Connection dimension	Ø 97 – 110 mm
Outlet dimension	DN110
Standard	DIN 1389
Recommended for	Toilet bowls with horizontal outlet
Additional information	with ball-joint, rosette HL7EL, gasket and ring

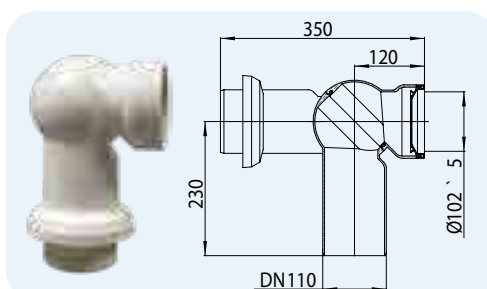

HL-No.	Dimension	Weight
210.7WE	DN110	475 g



EAN	Piece/package
+502172	5

HL222 Toilet connector kit

Data

Material	PP
Connection dimension	Ø 102 ± 5 mm
Outlet dimension	HL222/1: DN110 HL222/90: DN90
Standard	DIN 1389
Recommended for	Connection of waste and rinse water for wall-toilets
Additional information	Installation set available in delivery

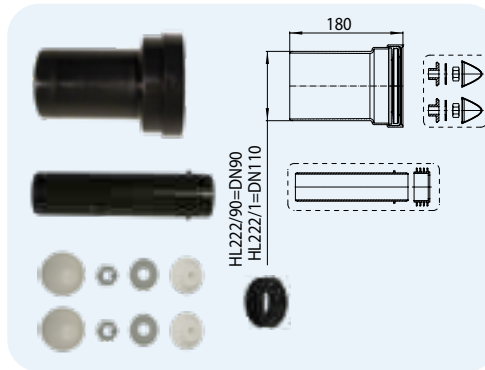

HL-No.	Dimension	Weight	EAN	Piece/package
222/1	DN110	325 g	+502226	1
222/90	DN90	310 g	+522293	1

HL224 Toilet elbow-connector

Data

Material	PP
Connection dimension	Ø 102 ± 5 mm
Outlet dimension	DN110
Standard	DIN 1389
Recommended for	Toilet bowls with horizontal outlet
Additional information	with cuttable inlet part and gasket

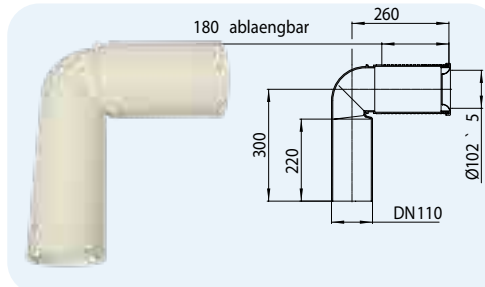

HL-No.	Dimension	Weight	EAN	Piece/package
224.WE	DN110	600 g	+502240	5

HL224.1 Toilet elbow-connector with pipe clip and fixing bracket

Data

Material	PP
Connection dimension	Ø 102 ± 5 mm
Outlet dimension	DN110
Standard	DIN 1389
Recommended for	Toilet bowls with horizontal outlet
Additional information	with cuttable inlet part, gasket, bracket and clip for toilet bowls with „Vario“-outlet

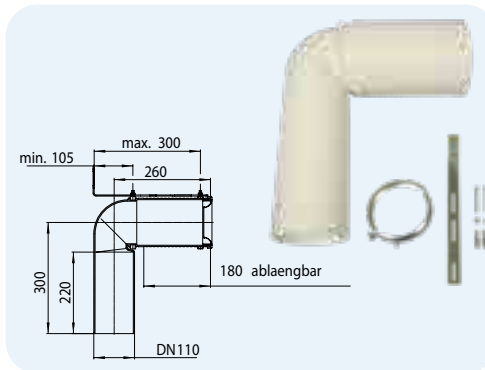

HL-No.	Dimension	Weight	EAN	Piece/package
224.1	DN110	1205 g	+512249	1

HL225/90 Toilet elbow-connector

Data

Material	PE
Connection dimension	Ø 97 – 110 mm
Outlet dimension	DN90/110
Standard	DIN 1389
Recommended for	Connectible to all 4 shell rings spots to ensure optimal connection
Additional information	cuttable inlet part, no connection to the wall, rubber gasket with support tube and lot cover

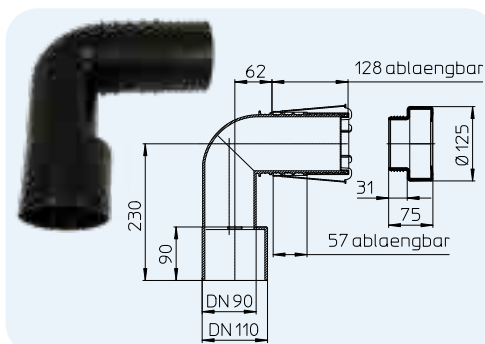

HL-No.	Dimension	Weight	EAN	Piece/package
225/90	DN90/110	860 g	+225903	5

HL225.1/90 Toilet elbow-connector with connector kit HL226
Data

Material	PE
Connection dimension	Ø 97 – 110 mm
Outlet dimension	DN90/110
Standard	DIN 1389
Recommended for	Connectible to all 4 shell rings spots to ensure optimal connection
Additional information	cuttable inlet part, no connection to the wall, rubber gasket with support tube and lot cover

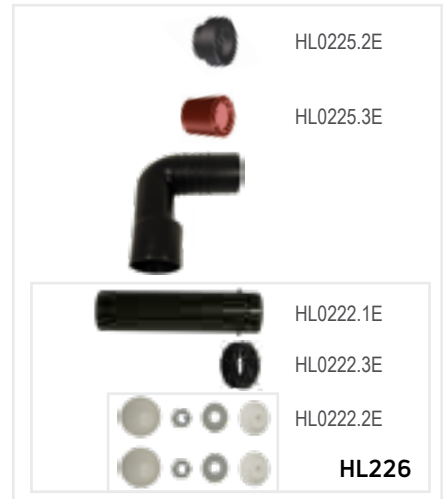
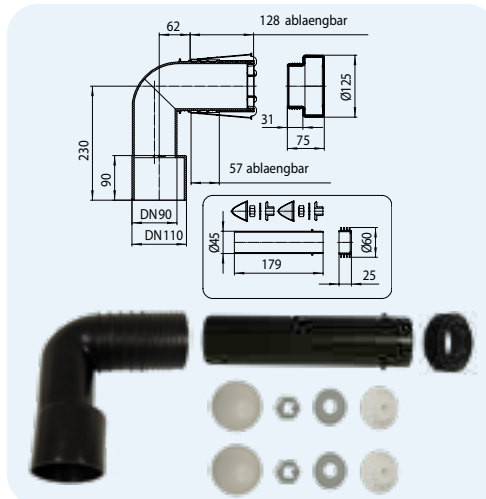

HL-No.	Dimension	Weight	EAN	Piece/package
225.1/90	DN90/110	980 g	+225194	5

HL703 Toilet elbow-connector with connector kit HL226
Data

Material	PP
Connection dimens.	Ø 97 – 110 mm
Outlet dimension	DN110
Standard	DIN 1389
Recommended for	"Problem-solver" for toilet bowls with backflush, caused by incorrect drainage
Additional information	with gasket and ring

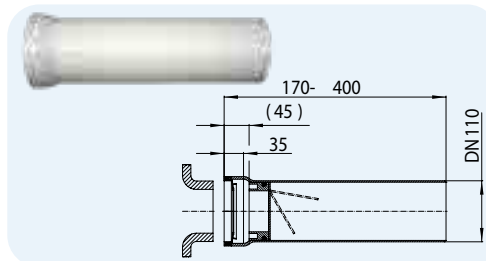

HL-No.	Dimension	Weight	EAN	Piece/package
703	DN110	530 g	+507030	1

HL Toilet connectors – Accessories – Data

HL7.WE Splitted toilet rosette
Data

Material	PP
Connection dimension	Ø 110 mm
Outlet dimension	Ø 160 mm
Recommended for	visual aprovement of wall or floor connections
Additional information	splittable rosette for finished installations

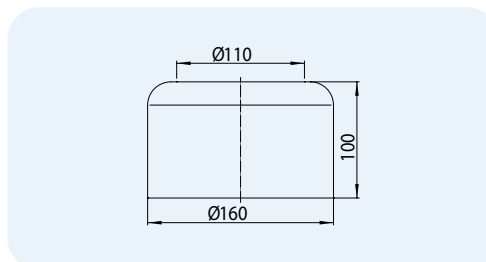

HL-No.	Dimension	Weight	EAN	Piece/package
7.WE	DN110	140 g	+502073	30

HL7EL Elastic toilet rosette, white
Data

Material	PE-soft
Connection dimension	HL7EL.WE: DN110 HL7EL/90WE: DN90
Outlet dimension	Ø 158 mm
Recommended for	visual aprovement of wall or floor connections
Additional information	elastic rosette

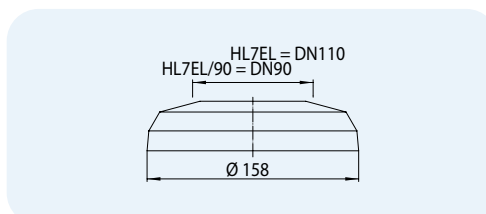

HL-No.	Dimension	Weight	EAN	Piece/package
7EL.WE	DN110	45 g	+500079	5
7EL/90WE	DN90	45 g	+501076	5



SIPHONS ABLÄUFE

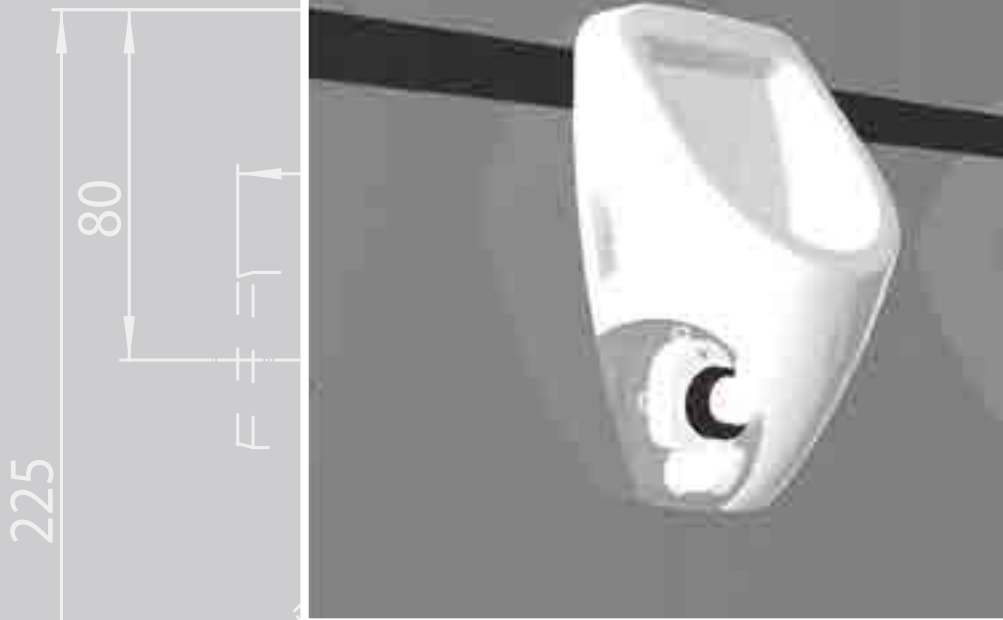
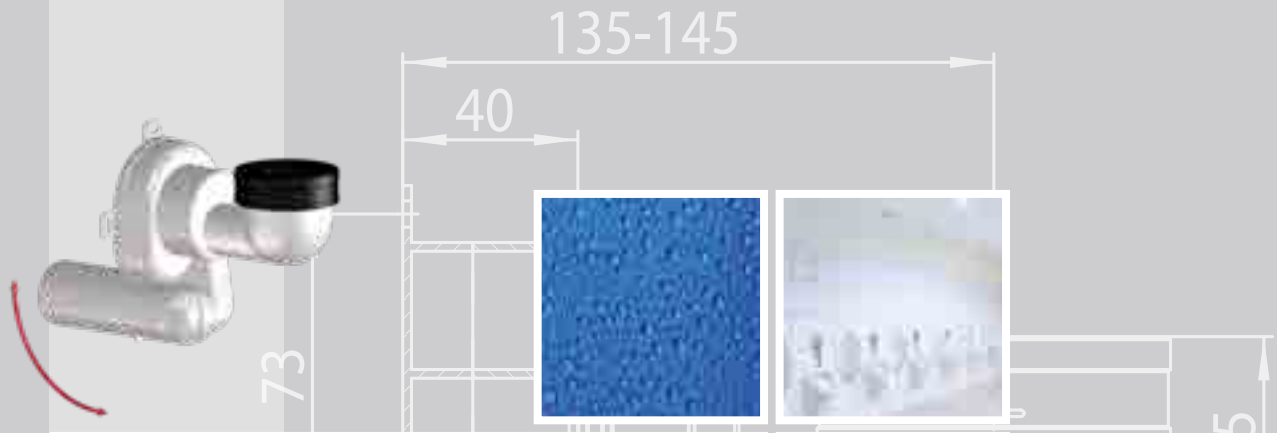

HL Siphons

100 9. Urinal

9



DN50
DN40

HL Urinal traps

Basic information about design and installation

Because of their low consumption of water urinals based on the principle of vacuum drainage have prevailed in the last years. Below we would like to clarify some of the terms, belonging to this chapter:

▲ Siphonic drainage

As urinal facilities mostly can be found in public areas, they have to be protected against unauthorised manipulation. Therefore the ceramic bowls are designed in a way, that all important parts are behind the bowl. That is why it is important to have a self-cleaning siphon. This effect results from using low cross sections inside the siphon and therefore higher flow speed. The trap is „systematically“ suctioned. The needed seal water has to come from which remains in the ceramic bowl. For this purpose only approved traps may be used, to make

sure, that this siphonic drainage effect happens indeed. HL urinal trap HL430 is conform to the standard. Additionally the function is approved by an independant laboratory.

▲ Flush volume

Normally urinal facilities are operated by electronic controls. Thereby the minimum flush volume can be regulated. Minimum flush volumes for HL urinal traps: HL431 and HL432: 1,5l for one flush. HL430: 1l for one flush.

▲ Plugging by urine scale

From the economical and ecological point of view people more and more use as little water for flushing as possible. However, it should be clear, that the less water is used for flushing, the more likely it will come to a plugging of the

trap and/or the drainage pipe. And this leads to shorter cleaning intervals.

▲ Ball-joint

HL equips it's traps with a ball-joint, which allows a stressless installation, both horizontal and vertical.

Relevant standards/directives

- DIN 13407 Wall-mounted urinals
- DIN 19541 Stench traps for special purposes
- DIN 1380 Connectors for urinals - requirements and verification

HL Urinal traps – Products – Data

HL130 Urinal trap

Data

Material	PP
Connection dimension	Ø 50 ± 2 mm
Outlet dimension	HL130/30: DN32 HL130/40: DN40
Capacity	0,7 l/s
Standard	DIN 19541, DIN 1380
Recommended for	urinals with vertical outlet
Additional information	Adjustable immersion tube, concealed lip-seal and rosette

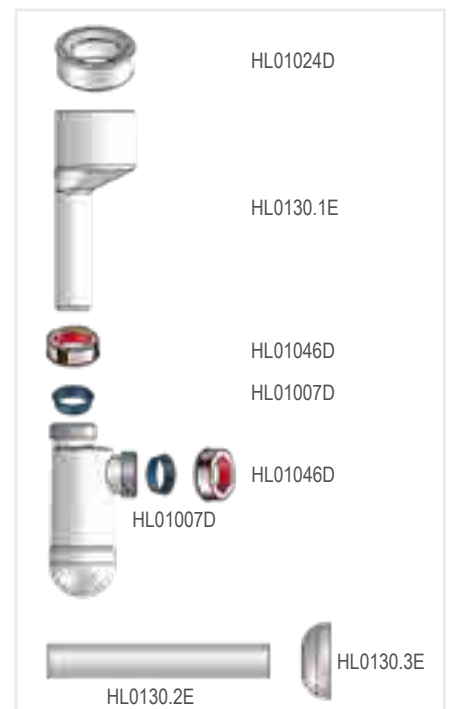
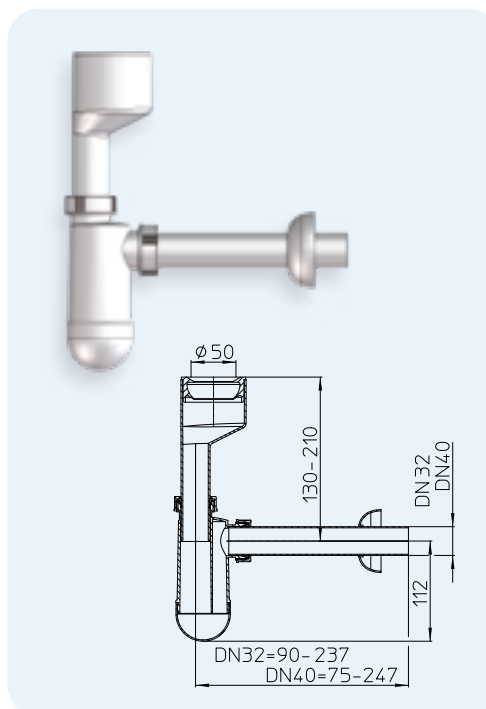

HL-No.	Dimension	Weight	EAN	Piece/package
130/30	DN32	260 g	+301300	1
130/40	DN40	265 g	+013043	1

HL430 Urinal siphonic trap

Data

Material	PP
Connection dimension	Ø 50 ± 2 mm
Outlet dimension	HL430/40: DN40 HL430/50: DN50
Capacity	0,7 l/s
Standard	EN 13407, DIN 19541, DIN 1380
Recommended for	Urinal bowls with internal horizontal outlet and > 1l flush volume
Additional information	Ball-joint (0° - 90°) and gasket

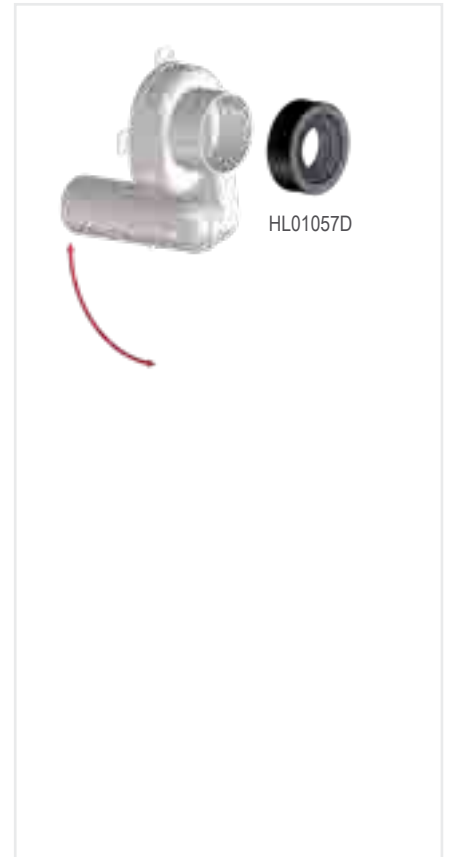
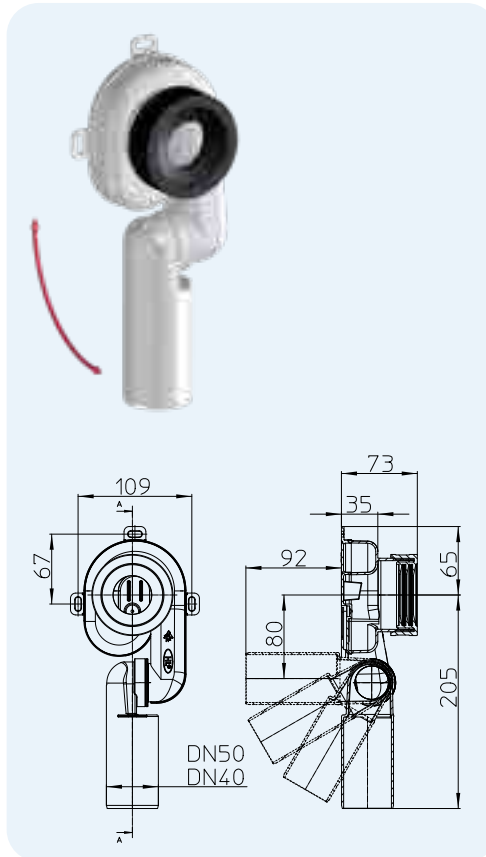

HL-No.	Dimension	Weight	EAN	Piece/package
430/40	DN40	180 g	+304301	10
430/50	DN50	185 g	+314300	10

HL431 Urinal siphonic trap

Data

Material	PP
Connection dimension	Ø 50 ± 2 mm
Outlet dimension	HL431/40: DN40 HL431/50: DN50
Capacity	0,7 l/s
Standard	EN 13407, DIN 19541, DIN 1380
Recommended for	Urinal bowls with internal vertical outlet
Additional information	Ball-joint (0° - 90°) and gasket

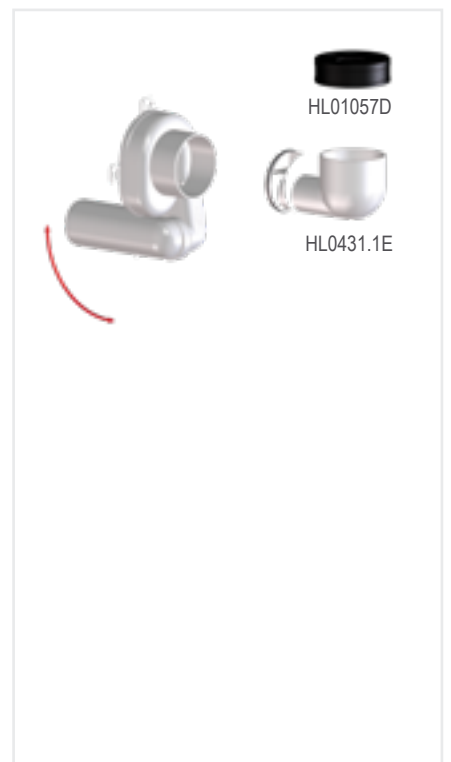
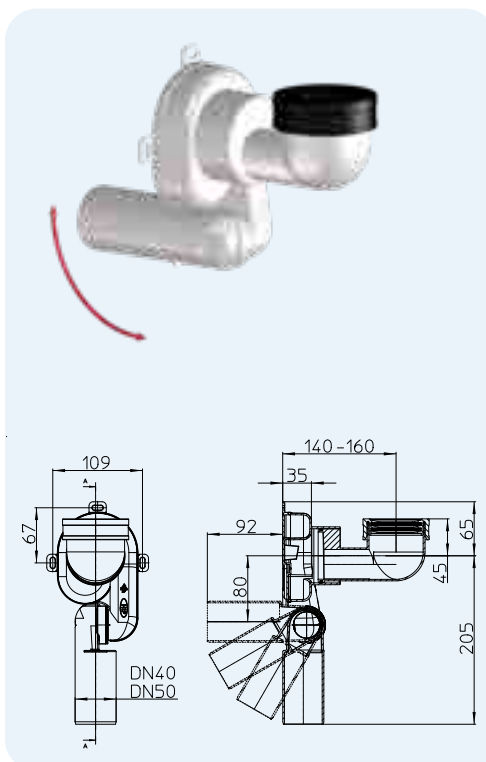

HL-No.	Dimension	Weight	EAN	Piece/package
431/40	DN40	250 g	+000777	10
431/50	DN50	260 g	+000791	10



SIPHONS ABLÄUFE



165

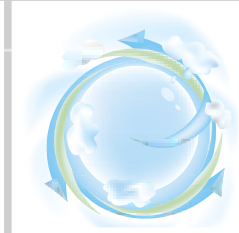

177

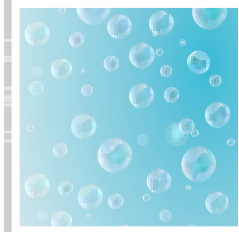

HL Article

10. Air admittance valves

10



DN50

DN75

48

HL Air admittance valves

Basic information about design and installation

Air admittance valves nowadays are part of nearly every drainage system. The main task of these valves is, to care on the one hand for an atmospherical pressure compensation in the drainage system and on the other hand to avoid stench coming up from the sewer. Please find below answers to the main questions.

▲ Is it necessary to lead the downpipe over the roof?

Yes. Minimum one downpipe has to lead into the fresh air, which cares for the ventilation and also for the deaeration of the sewer system (also valid for passive houses acc. Austrian Standard B2501)

▲ What is the sense of air admittance valves?

When wastewater runs down the drainage system, it comes to a vacuum, which might suck out the water in the stench trap. Air admittance valves care for pressure compensation and avoid nasty side effects like gurgling, emptying of the siphon or stench. They may be installed with little effort.

▲ When does one have to use air admittance valves?

Single or multiple drainage pipes, which are longer than **4 m** away from the downpipe have to be equipped with ventpipes (air admittance valves). Minimum one downpipe must be installed over the roof, all other downpipes may be ventilated with air admittance valves.

▲ Where are they used?

At downpipes above the last drained device (e.g. above the highest toilet. The advantage is, that the pipe may not be lead through the ceiling into the attic). Also at renovations, when a single trap has to be ventilated, to solve existing problems.

▲ How do air admittance valves work?

Inside the ventpipe a rubber disc regulates the air flow. This membrane closes the air inlet, when there is no pressure or overpressure and avoids air (or stench) coming up from the sewer. This is the reason, why these valves must be installed always vertically.

▲ Position fo installation/operating temperature

Air admittance valves must be installed in that way, that enough air from the surrounding may get into the sewer system. The operating temperature is described in DIN1986-100 and EN12380. E.g. our ventpipe HL900N has, acc. to these standards, classification A-I, highest range from -20°C to +60°C.

▲ Is it allowed to use ventpipes below the flood level?

Yes, but only, when the drain pipe is secured against backwater.

▲ Is it allowed to use air admittance valves to ventilate lift stations?

No, lift stations must be connected to one main ventilation pipe, which leads above the roof.

▲ Maintenance

Take care, that air admittance valves are installed in places, where it is possible to clean or, in case of damage, replace them. For cleaning HL provides it's ventpipes with an insect screen, which can be easily removed for cleaning. In general one can say, that, as long as there is no stench problem in the drainage system, the air admittance valve works for long time.

▲ Savety

To reach highest functioning, we recommend to use only design approved and externally controlled types.

Relevant standards/directives

- EN 12056-2 Gravity drainage systems inside of buildings
- EN12380..... Air admittance valves for soil and waste systems
- DIN 1986-100 Drainage systems for buildings and estates
- ÖNORM B2501 Drainage of buildings

HL Air admittance valve - Calculation - Function

Calculation example for an apartment building with restaurant according to the calculation formula in EN 12056-2.

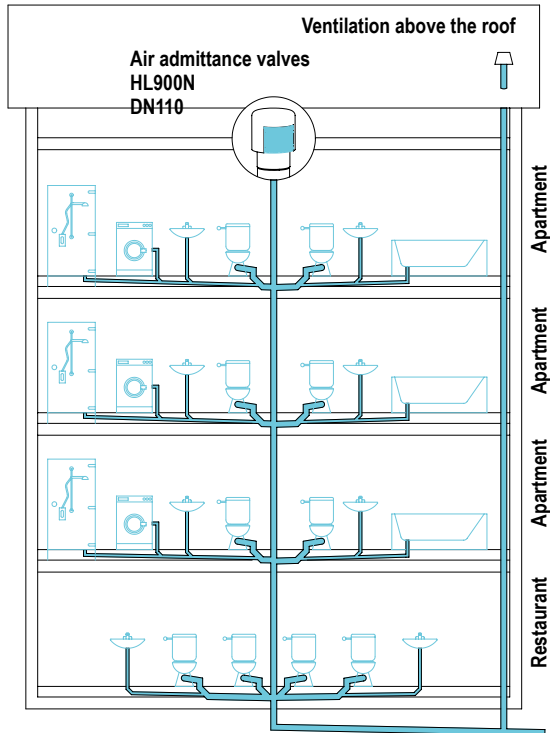

$$Q_{ww} = K \sqrt{\sum DU}$$

Definition of terms:

Q_{ww} = Waste water quantity (l/s)

K = Waste water coefficient

$\sum DU$ = Total connected value of drained units

Q_a = required quantity of air

Apartments	
6 WC's with 7,5 l toilet tank	6 x 2,0 l/s = 12 l/s
6 washbasins	6 x 0,5 l/s = 3 l/s
3 bath tubs	3 x 0,8 l/s = 2,4 l/s
3 showers	3 x 0,6 l/s = 1,8 l/s
3 washing machines	3 x 0,8 l/s = 2,4 l/s
Total	21,6 l/s

Restaurant	
4 WCs with 7,5 l toilet tank	4 x 2,0 l/s = 8 l/s
2 washbasins	2 x 0,5 l/s = 1 l/s
Total	9 l/s

Q_{ww} Apartments = $0,5 \times \sqrt{21,6} \text{ l/s} = 0,5 \times 4,65 \text{ l/s} = 2,33 \text{ l/s}$ (Q_{tot})

Q_{ww} Restaurant = $0,7 \times \sqrt{9} \text{ l/s} = 0,7 \times 3 \text{ l/s} = 2,1 \text{ l/s}$ (Q_{tot})

$Q_a = 8 \times (Q_{tot} \text{ Apartments} + Q_{tot} \text{ Restaurant})$

$Q_a = 8 \times 4,43 \text{ l/s} = 35,44 \text{ l/s}$

Airflow capacity of HL900N = 37 l/s

Function

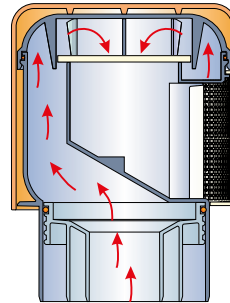

At overpressure in the sewer system the valve stays closed. No stench can get out.

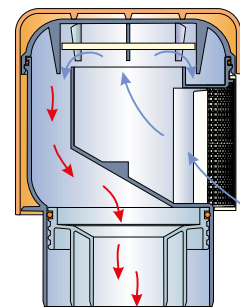

At vacuum in the sewer the valve opens and the inflowing air causes pressure compensation.

Typical waste water coefficients (K)

Irregular use like e.g. in apartment buildings, b&bs, offices	0,5
Regular use like e.g. in hospitals, schools, restaurants, hotels	0,7
Frequent use like e.g. in public toilets and/or showers	1
Special use like e.g. in laboratories	1,2

Excerpt from EN 12056-2 chart 2

Waste water values

Drained unit	Value
	DU (l/s)
Washbasins, bidet	0,5
Shower without plug	0,6
Shower with plug	0,8
Bathtub	0,8
Kitchen sink	0,8
Dish washer	0,8
Washing machine up to 6 kg	0,8
Washing machine up to 12 kg	1,5
WC with 7,5 l toilet tank	2,0
Floor drain DN50	0,8
Floor drain DN70	1,5
Floor drain DN100	2,0

HL Air admittance valves – Products – Data

HL900N Air admittance valve with reduction

Data

Material	PP	Bauart geprüft und überwacht www.hlx.com ID: 1111218824
Connection dimension	DN110/75/50 Socket	
Airflow capacity	37 l/s	
Standard	EN 12380, type A1 design approved	
Recommended for	Ventilation of single or multiple downpipes	
Additional information	with removable insect screen (easy cleaning), solid rubber disc, double wall thermal insulation and reduction DN50/75	

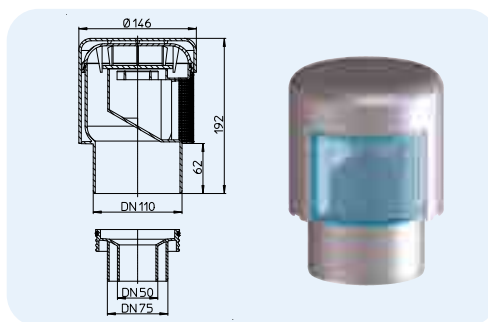

HL-No.	Dimension	Weight	EAN	Piece/package
900N	DN110/75/50	550 g	+909001	10

HL900NECO Air admittance valve

Data

Material	PP	Bauart geprüft und überwacht www.hlx.com ID: 1111218824
Connection dimension	DN110	
Airflow capacity	37 l/s	
Standard	EN 12380, type A1 design approved	
Recommended for	Ventilation of single or multiple downpipes	
Additional information	with removable insect screen (easy cleaning), solid rubber disc and double wall thermal insulation	

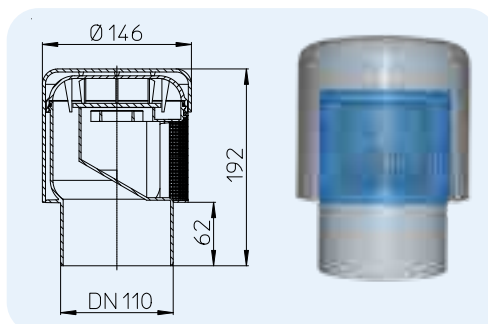

HL-No.	Dimension	Weight	EAN	Piece/package
900NECO	DN110	470 g	+016839	10

HL901 Air admittance valve

Data

Material	PP	Bauart geprüft und überwacht www.hlx.com ID: 1111218824
Connection dimension	DN75/110 plain pipe DN90 Socket	
Airflow capacity	32 l/s	
Standard	EN 12380, type A1 design approved	
Recommended for	Ventilation of single or multiple downpipes	
Additional information	with removable insect screen (easy cleaning), solid rubber disc and double wall thermal insulation, flat!	

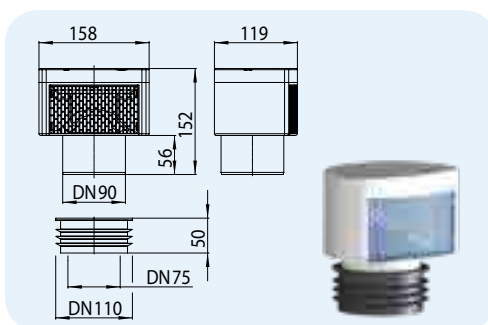

HL-No.	Dimension	Weight	EAN	Piece/package
901	DN75/90/110	362 g	+031269	10

HL904 Air admittance valve

Data

Material	PP	Bauart geprüft und überwacht www.hlx.com ID: 1111218824
Connection dimension	DN32/50 Socket DN40 plain pipe	
Airflow capacity	5,5 l/s	
Standard	EN 12380, type A1 design approved	
Recommended for	Ventilation of single drain units and collected units	
Additional information	with adapter	

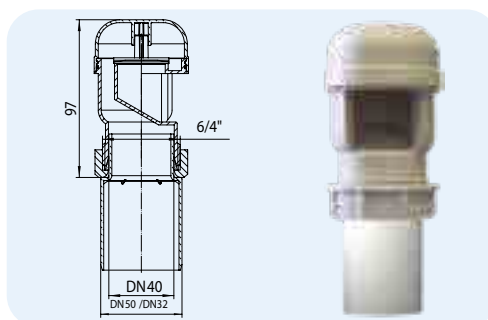

HL-No.	Dimension	Weight	EAN	Piece/package
904	DN32/40/50	90 g	+909049	10

HL904T Air admittance valve with T-connector

Data

Material	PP	Bauart geprüft und überwacht www.tuv.com ID: 1111218824
Connection dimension	DN40 plain pipe	
Airflow capacity	5,5 l/s	
Standard	EN 12380, type A1 design approved	
Recommended for	Ventilation of single drain units and collected units	
Additional information	with T-connector and adapter	

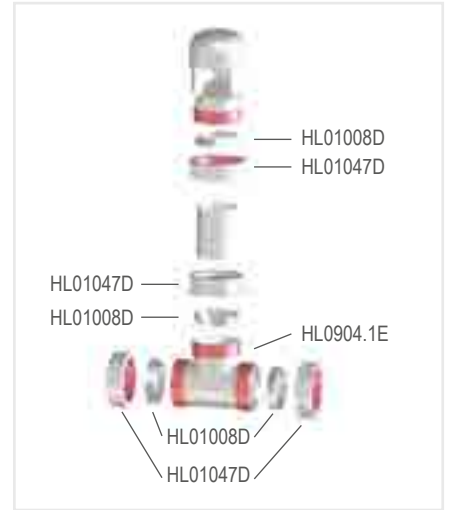
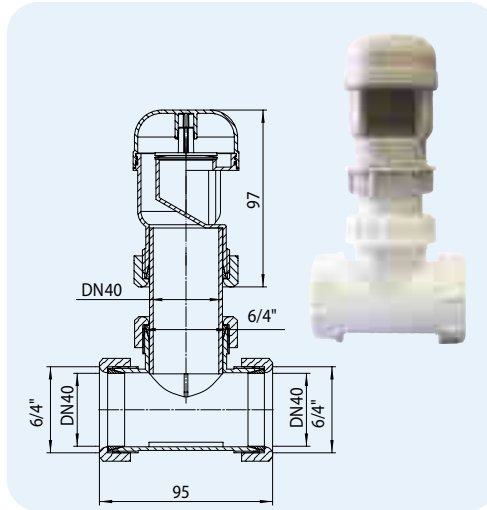

HL-No.	Dimension	Weight	EAN	Piece/package
904T	DN40	136 g	+919048	1

HL903 Air admittance valve

Data

Material	ABS/PP	Bauart geprüft und überwacht www.tuv.com ID: 1111218824
Connection dimension	DN32/50 Socket DN40 plain pipe	
Airflow capacity	8 l/s	
Standard	EN 12380, type A1 design approved	
Recommended for	Ventilation of single drain units and collected units	
Additional information	With removable insect screen, adapter and double wall thermal insulation.	

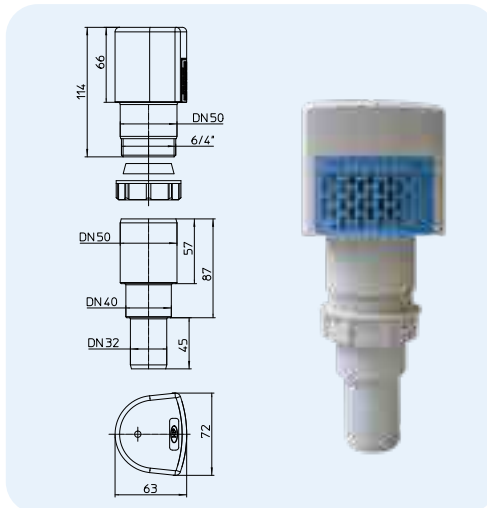

HL-No.	Dimension	Weight	EAN	Piece/package
903	DN32/40/50	139 g	+029013	10

HL902T Air admittance valve with T-connector

Data

Material	PP
Connection dimension	HL902T/30: DN30 plain pipe HL902T/40: DN40 plain pipe
Airflow capacity	8 l/s
Standard	EN 12380
Recommended for	Ventilation of single drain units

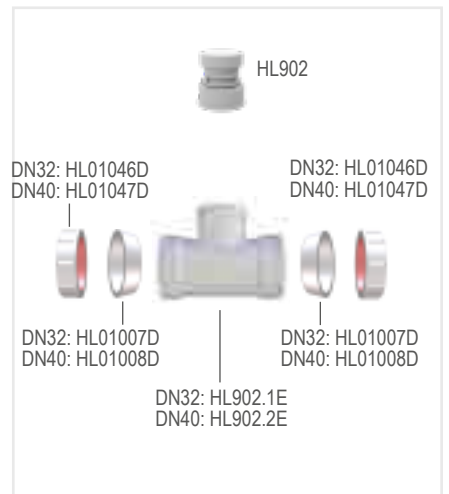
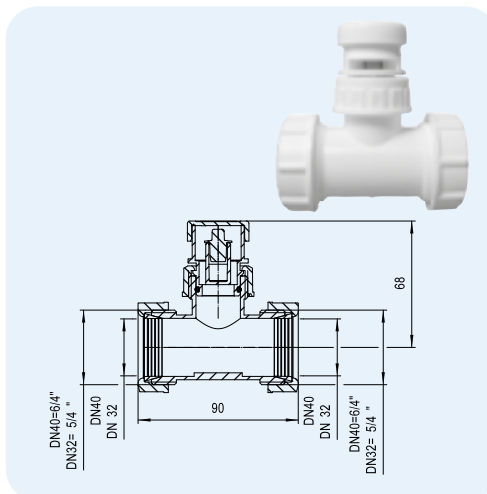

HL-No.	Dimension	Weight	EAN	Piece/package
902T/30	DN32 x 1"	75 g	+004836	1
902T/40	DN40 x 1"	80 g	+004850	1

HL905N Flat concealed air admittance valve complet with white cover

Data

Material PP/ABS
 Connection DN50/75
 Airflow capacity 13 l/s
 Standard EN 12380-A1,
 EN 12056-2



Basart geprüft
 und überwacht
 www.tuv.com
 ID: 111216224

Recommended for In-wall installation, ventilation of secondary downpipes and single- or multiple downpipes, which are more than 4m away from the downpipe (EN12056-2)
 Due to the flat design an installation in plasterboard walls with 75mm inner dimension is possible

Additional information By installing this air admittance valve, you make sure, that enough air is getting into the outlet pipes of the whole bathroom, so the water inside the trap is not sucked out by vacuum, which might cause bad odour. The functional cartridge is removable for cleaning and revision and, additionally, allows an open access to the sewer system. Please see installation video at www.hl.at

HL905N

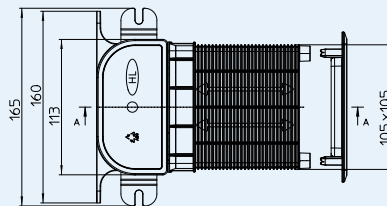
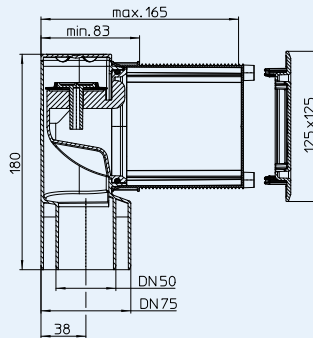

HL-No.	Dimension	Cover	Weight	EAN	Piece/package
905N	DN50/75	white	383 g	+049752	1
905N.0	DN50/75	without cover	336 g	+049769	1

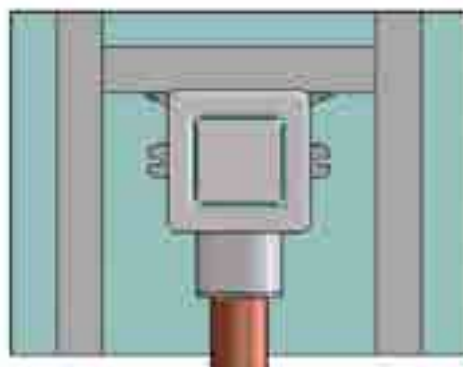
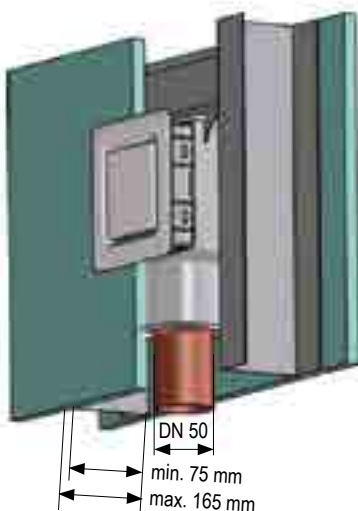

HL905.1, (.2), (3), (.4) Cover plate for HL905N
HL905.1V, (.2V) Screwable cover for HL905N

Data

Material HL905.1: ABS
 Dimension 125 x 125 mm
 Recommended for HL905N

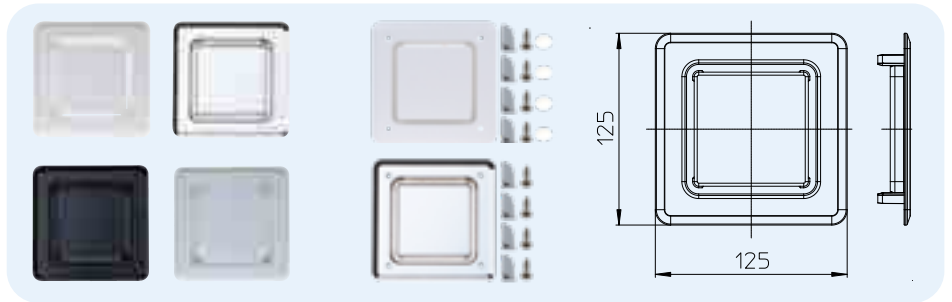

HL-No.	Dimension	Colour	Weight	EAN	Piece/package
905.1	125 x 125 mm	White	47 g	+036080	1
905.1V	125 x 125 mm	White	78 g	+603814	1
905.2	125 x 125 mm	Chromated	47 g	+037117	1
905.2V	125 x 125 mm	Chromated	78 g	+603815	1
905.3	125 x 125 mm	Black	47 g	+037124	1
905.4	125 x 125 mm	Gray	47 g	+037131	1



HL Air admittance valves – Accessories – Data

HL902 Air admittance valve

Data

Material	PP
Connection dimension	1" IG
Airflow capacity	8 l/s
Standard	EN 12380
Recommended for	Ventilation of single drain units

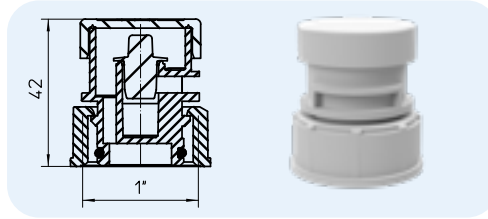

HL-No.	Dimension	Weight	EAN	Piece/package
902	1"	30 g	+909025	10

HL0317.4E Reduction DN75 x DN110

Data

Material	PP
Connection dimension	DN75 socket DN110 straight end
Recommended for	Reduction of HL905

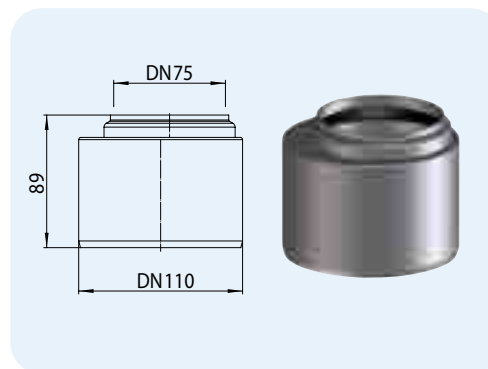

HL-No.	Dimension	Weight	EAN	Piece/package
0317.4E	DN75/110	104 g	+317042	1

HL990 Reduction

Data

Material	PP
Connection dimension	DN75/90
Recommended for	fits to HL900N (ECO)

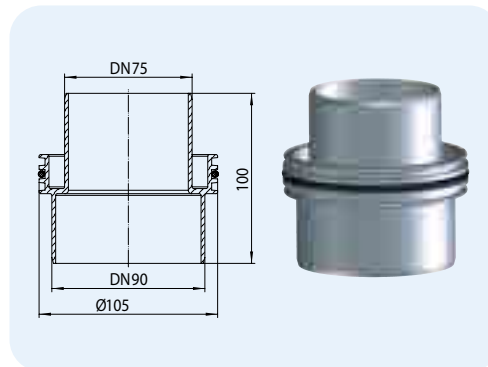

HL-No.	Dimension	Weight	EAN	Piece/package
990	DN75/90	97 g	+018246	1



SIPHONS ABLÄUFE

Ø 354



101

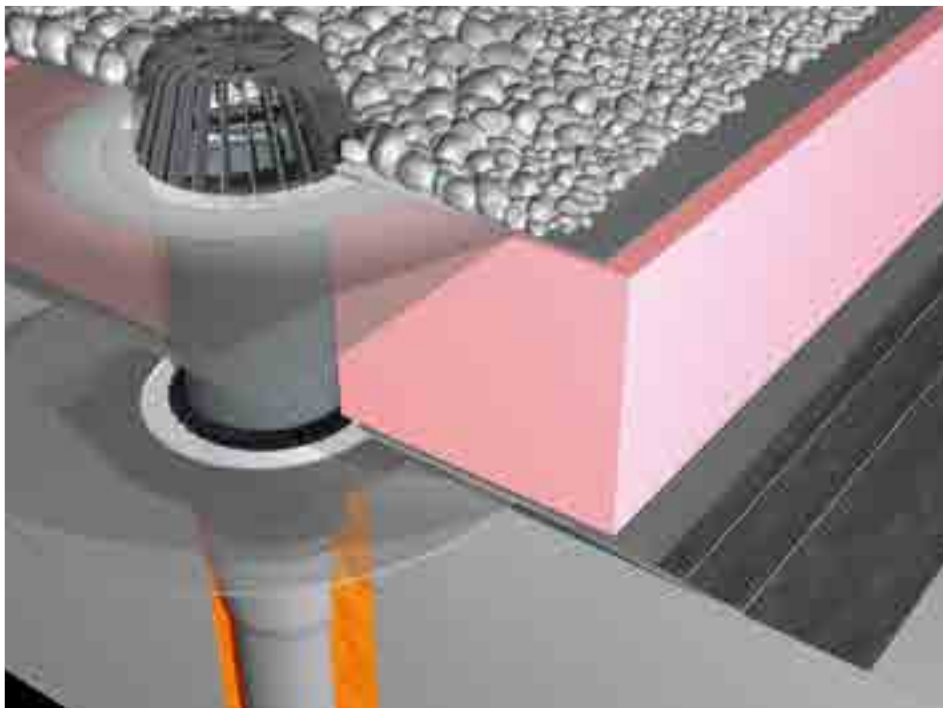

HL Drains

11. Roof

11



HL Roof drains

Basic information about design and installation

For conventional roof drainage systems HL provides solutions for nearly every kind of roof construction. The challenge for the designer and the installer is very detailed. Different constructions, layer compositions and roof functions ask for varied drain combinations. Before designing please notice following topics:

- ▲ Calculation of the quantity of roof drains
First the quantity of rainwater has to be calculated. Acc. EN12056 and ÖNORM B2501 this is a minimum 300l/ (s x ha), which means one incident of intense rain, happening one time within 5 years for the time of 5 minutes. If this data is higher at the location of construction, this higher rain yield factor has to be taken into consideration for the calculation (please ask your local meteorological station).
Example: Roof surface = 1500m², rain yield factor = 400l/ (s x ha), coefficient 1
Rain water quantity, which has to be drained off = (400 x 1 x 1500) / 10.000 = 60 l/s.
Basically every low point of the roof should be provided with a single drain.
Anyway, the number of drains and the drain capacities has to be at least the calculated rain yield factor.
Example: Rain yield factor = 60 l/s,
drain capacity of the roof drain = 5 l/s
Quantity of roof drains = 60/5 = 12 roof drains

- ▲ Emergency overflows
To protect from damages, please check acc. DIN 1986-100 and ÖNORM B2501 (or local standard), if emergency overflows are requested. Acc. DIN 1986-100 and ÖNORM B2501 it has to be checked at all roof constructions, if emergency overflows are necessary, considering the expected incidents of rain at the

construction site, the construction itself, the hydro-insulation, the statics of the roof and the special character of the drainage system. Two possibilities: Installation of a second drainage system or draining off by a gap in the attic. The quantity of rain water, drained off by emergency overflows, results from the difference between the century and the standard rain yield factor. (The term „century rain yield factor“ means a heavy rain incident, which may occur one time in 100 years for the time of 5 minutes).

Example:
Century rain yield factor = 800 l/ (s x ha),
standard rain yield factor = 400 l/ (s x ha)
Rain water quantity for emergency overflows = 800 - 400 = 400 l/ (s x ha).

- ▲ Waterproofing
Empirically roof openings most often are responsible for damages by water. That means, you have to pay most attention already during the period of designing, to have a 100% waterproof connection between the sheeting and the gully. HL provides solutions for all established waterproof sheeting. We recommend to use gullies, which are prefabricated with flanges made off the same material, as the sheeting.

- ▲ Drainage layers
Depending on the roof design, there might be more than one layer, which has to be drained off. Please take care, that each layer, where water may occur, is drained off (e.g. by a gravel guard).

- ▲ Heating
To avoid the freezing of the gully during the winter time, we recommend generally the installation of a roof drain with integrated heating. From our experience, these drains are installed, when they are connected to only storm water sewers. A heated gully is absolutely necessary, when it is at a position, where snow water may occur during day, whilst at night it might be blocked by ice.

- ▲ Condensed water
Roof drains should have an integrated thermo-insulation, to avoid, that condensed water arises (e.g. all HL roof drains have a double wall drain body, which functions as thermo-insulation).

Relevant standards/directives

ÖNORM B 2501 Drainage of buildings
DIN 1986-100 Drainage systems for buildings and estates
EN 1253 Drains for buildings
ÖNORM B 2209 Waterproofing works
ÖNORM B 2220 Roof waterproofings with bitumen and plastic sheetings
ÖNORM B 7209 Waterproofings for buildings
ÖNORM B 7220 Roofs with waterproofings

Selection of the convenient drain

Selective criteria	Requirements	Product
Drainage surface	<p>When you calculate the quantity of occurring rain water acc. ÖNORM B2501 and DIN 1986-100, you have to use at least the standard rain yield factor of 300 l / (s x ha).</p> <p>Quantity of rain water = 0,03 l/s x drainage surface (m²)</p> <p>Quantity of gullies = $\frac{\text{Absolute quantity of rain water}}{\text{Capacity of the gully}}$</p>	For the exact definition of the right drain and the quantity of gullies, please mind the capacity of the particular article.
Waterproofing	<p>For the right choice of the convenient drain, please find out, which waterproof sheeting material is used on the roof.</p> <p>Please prefer drains with prefabricated PVC- or bitumen flanges, when the roof is sheeted with PVC or bitumen.</p> <p>For all other sheeting you may use drains with a clamping ring.</p> <p>Bitumen sheeting, liquid bitumen compounds</p> <p>PVC-sheeting</p> <p>FPO-sheeting</p> <p>Polymer sheeting</p>	<p>Roof drain vertical HL62H Roof drain horizontal HL64H</p> <p>Roof drain vertical HL62P Roof drain horizontal HL64P</p> <p>Roof drain vertical HL62F Roof drain horizontal HL64F</p> <p>Roof drain vertical HL62 Roof drain horizontal HL64</p>
Roof construction	<p>To find out, what is the best composition of the drain, like extension (with our without flange), gravel guard (e.g. for inverted roofs) or heating, a detailed plan of the different layers is necessary.</p> <p>Extension with flange for e.g. warm roofs</p> <p>Gravel guard for e.g. inverted roofs</p> <p>Extension with flange</p> <p>Extension</p> <p>Drainage- and inspection-chamber</p>	<p>HL65(H)(P)(F)(PE)</p> <p>HL160, HL161</p> <p>HL350.0</p> <p>HL350</p> <p>HL635N</p>
Heating	<p>All types of roof drains, signed with the appendix „1“ are equipped with an integrated, self-adjusting 230 V heating (10 - 30 Watt). We recommend gullies with heating especially, when the drainage system is connected to the rainwater drain.</p>	„1“
Siphon trap	<p>All types of drains are without siphon trap.</p> <p>If the drainage system is connected to the sewer, it is possible, to install a central, vertical flap valve for down pipes below the roof as a stench trap.</p>	HL603

HL Roof drains – Installation examples – Warm roof

Extensive green roof

- Gravel
- Substrate/soil
- Filtering fleece
- Drainage element
- Two layer bitumen waterproofing
- Thermal insulation
- Bitumen vapour barrier
- Slope
- Concrete

HL160
HL65H
HL64BH

Intensive green roof with drainage and inspection chamber

- HL635N
- Gravel
- Substrate/soil
- Filtering fleece
- Drainage element
- Two layer bitumen waterproofing
- Thermal insulation
- Slope
- Concrete

HL636N
HL62H
HL65H
Bitumen vapour barrier

Gravel roof

- Gravel
- Filtering fleece
- Two layer bitumen waterproofing
- Thermal insulation
- Bitumen vapour barrier
- Slope
- Concrete

HL62H
HL65H

Lightweight design with gravel

- Gravel
- Filtering fleece
- Two layer bitumen waterproofing
- Thermal insulation
- Vapour barrier
- Trapezoidal sheet

HL62F
HL65H

Further installation examples can be found at <http://hl.blucina.net>

HL Roof drains – Installation examples – Inverted roof

Stone slabs on gravel

HL62BH

- Slabs
- Gravel
- Filtering fleece
- Thermal insulation
- Two layer bitumen waterproofing
- Slope
- Concrete
- HL160
- HL65
- HL161

Stone slabs on gravel with drainage and inspection chamber

HL635N.0

HL62H

- HL0635N.2
- Slabs
- Gravel
- Filtering fleece
- Thermal insulation
- Two layer bitumen waterproofing
- Slope
- Concrete
- HL65
- HL161

Intensive green roof with drainage- and inspection chamber

HL62H

- HL635N
- Gravel
- Substrate/soil
- Filtering fleece
- Thermal insulation
- Two layer bitumen waterproofing
- Slope
- Concrete
- HL65
- HL161

Emergency drainage for green roofs with drainage- and inspection chamber

HL62HSafe

- HL635N
- Gravel
- Substrate/soil
- Filtering fleece
- Thermal insulation
- Two layer bitumen waterproofing
- Slope
- Concrete
- HL65

HL Roof drains – Installation

Thermal insulated inverted roof with gravel embankment



1. Produce tap hole with Ø 255 mm, insert drain HL62H



2. Apply prime coat on the raw ceiling



3. Weld the first bitumen layer on the raw ceiling, then weld the bitumen flange of the drain on the bitumen layer



4. Connect second bitumen layer with the bitumen flange of the drain



5. Professional integration of the gully in a 2-layer bitumen sheeting



6. Remove lid cover, apply the fleece, insert gravel guard HL160



7. Put the extension HL350.0 on the gravel guard HL160



8. Set the thermal insulation plates, adjust the height of the extension by cutting



9. Insert the transparent plastic ring in the groove of the flange



10. Clamp the fleece on the flange with the stainless steel ring



11. Insert leaf catcher, dispense the gravel with minimum grain size 16/32 around the leaf catcher



12. Fill with gravel



HL Roof drains – Products – Overview

Drains



Product	HL62	HL62H	HL62P	HL62F	HL64
Description	Standard roof drain vertical with clamp ring	Roof drain vertical with bitumen membrane	Roof drain vertical with PVC-flange	Roof drain vertical with PP-flange	Standard roof drain horizontal with clamp ring
Function	To clamp polymer sheeting	Especially for connection to bitumen sheeting	Especially for connection to PVC-sheeting	Especially for connection to FPO-sheeting based on PP	For clamping of polymer sheeting

All drains of series HL62 and HL64 are also available with an assembly kit for terraces.
 All drains of series HL62 and HL64 are also available with integrated heating.
 For more information see product data.

Drains

More spare parts for HL80.3 and HL80.3H find in chapter „balcony - terraces“.



Product	HL80.3	HL80.3H
Description	Flat roof drain	Flat roof drain with bitumen flange
Function	For roof areas up to 33 m ² and rain yield factor of 300 l / (s x ha)	For roof areas up to 33 m ² and rain yield factor of 300 l / (s x ha) especially for connection to bitumen sheeting

Extensions



Product	HL65	HL65H	HL65P	HL65F(HL65PE)	HL350	HL350.0
Description	Standard extension	Extension with bitumen flange	Extension with PVC-flange	The extension with PP or PE flange	Extension	Extension with insulation set
Function	For clamping of polymer sheeting, e.g. warm roofs	Especially for connection to bitumen sheeting, e.g. warm roofs	Especially for connection to PVC sheeting, e.g. warm roofs	Especially for connection to FPO based on PP or PE	To extend the leaf catcher or the grating of the walkable type	To extend the leaf catcher or the grating of the walkable type with additional clamp ring

HL Roof drains – Products – Overview



HL64H

Roof drain horizontal with bitumen membrane

Especially for connection to bitumen sheeting

HL64P

Roof drain horizontal with PVC-flange

Especially for connection to PVC-sheeting

HL64F

Roof drain horizontal with PP-flange

Especially for connection to FPO sheeting based on PP

HL69

Flat-roof renovation drain vertical with clamp ring

For clamping of polymer sheeting and for the renovation of the drainage system. Easily to be plugged into the body of the old drain

HL69H

Flat-roof renovation drain vertical with bitumen membrane

Especially for connection to bitumen sheeting and for the renovation of the drainage system. Easily to be plugged into the body of the old drain

HL69P

Flat-roof renovation drain vertical with PVC-flange

Especially for connection to PVC sheeting and for the renovation of the drainage system. Easily to be plugged into the body of the old drain

Sealing kits

Product data please see Chapter Sealing kits-Extensions

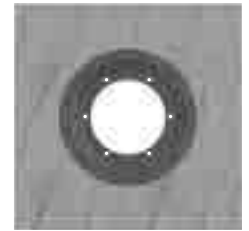

Product

HL84.H

HL84.CU

HL84.E

HL84.L

Description

Sealing kit with bitumen membrane

Sealing kit with copper plate

Sealing kit with galvanized steel plate

Sealing kit with fleece laminated membrane

Function

For clamping to a standard roof drain or a standard extension. „Problem solver“

Fits to a standard roof drain or to a standard extension - for roofs with copper sheeting

Fits to a standard roof drain or to a standard extension - for roofs with steel sheeting

Fits to a standard roof drain or to a standard extension - for solvent-free liquid waterproofing

Accessories



Product

HL160

HL161

HL66.9

HL635N

HL603

Description

Gravel guard for inverted roofs

Drainage element

Walkable extension

Stainless steel leaf catcher

Flap valve for downpipes DN110 or DN160

Function

For the drainage of rainwater on the hydro-insulation layer, e.g. inverted roof construction

For drainage of condensation water on the vapour barrier, e.g. with aered flat roofs.

To convert roof drains with leaf catcher to a walkable type

Fits for all roof drains and extensions with clamp ring

Prevents from sewer stench

HL Roof drains – Products – Data

HL62 Roof drain with thermal insulation HL62.1 Roof drain like HL62, but electrically heated

Data	
Material	PP, drain body thermal insulated
Outlet	vertical
Sealing flange	PP with stainless steel clamp ring
Inlet	Leaf catcher Ø 170 mm
Standard	EN 1253
Recommended for	Polymer sheeting
Additional information	Notch dimension: 255 x 380 mm Tap hole dimension: Ø 255 mm
Including	Lid cover, 6 pcs. HL062N.4E hex nut alternative to wing nuts

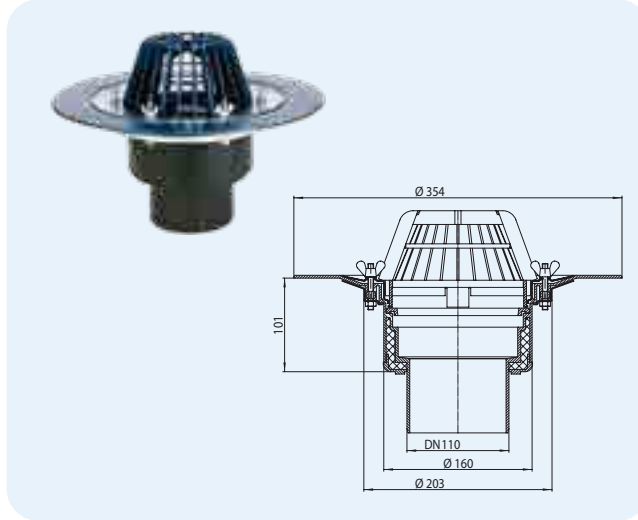

HL-No.	Dimension	Weight	EAN	Piece/package	Type
62/7	DN75	1507 g	+830626	1	Standard
62.1/7	DN75	1647 g	+832620	1	with heating
62/1	DN110	1486 g	+800629	1	Standard
62.1/1	DN110	1626 g	+802623	1	with heating
62/2	DN125	1481 g	+810628	1	Standard
62.1/2	DN125	1621 g	+812622	1	with heating
62/5	DN160	1515 g	+820627	1	Standard
62.1/5	DN160	1655 g	+822621	1	with heating

HL62H Roof drain with bitumen membrane HL62.1H Roof drain like HL62H, but with electrical heating

Data	
Material	PP, drain body thermal insulated
Outlet	vertical
Sealing flange	PP, stainless steel, prefabricated welded bitumen membrane
Inlet	Leaf catcher Ø 170 mm
Standard	EN 1253
Recommended for	Bitumen sheeting
Additional information	Notch dimension: 255 x 380 mm Tap hole dimension: Ø 255 mm
Including	Lid cover

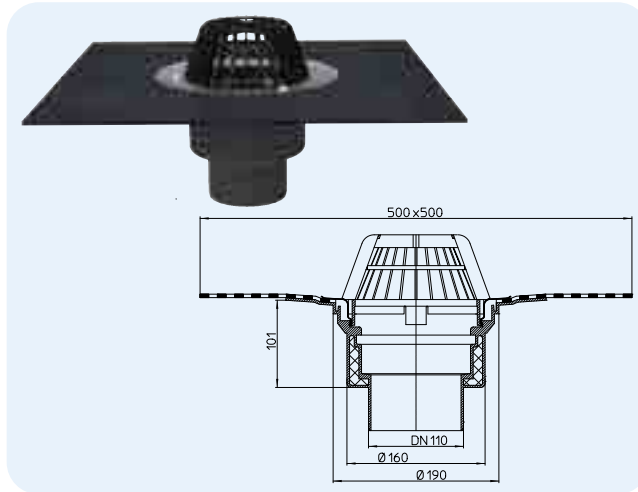

HL-No.	Dimension	Weight	EAN	Piece/package	Type
62H/7	DN75	1853 g	+831623	1	Standard
62.1H/7	DN75	1993 g	+806225	1	with heating
62H/1	DN110	1832 g	+801626	1	Standard
62.1H/1	DN110	1972 g	+816217	1	with heating
62H/2	DN125	1827 g	+811625	1	Standard
62.1H/2	DN125	1967 g	+826216	1	with heating
62H/5	DN160	1861 g	+821624	1	Standard
62.1H/5	DN160	2001 g	+836215	1	with heating

Drainage table HL62, HL62.1, HL62H, HL62.1H

Tested according to EN 1253-2:2015 according to pt. 5.5.2.1 Fig. 10a) + 10b)
Drainage capacity tested according to EN 1253-2:2015 according to pt. 5.5.2.1 on downpipe 3 m

Nominal width	EN 1253	5 mm	15 mm	25 mm	35 mm	45 mm	55 mm	65 mm	75 mm
DN75 vertical	min. 1,7 (35 mm)	0,9	3,5	6,8	9,9	13,2	15,0	15,1	15,2
DN110 vertical	min. 4,5 (35 mm)	1,0	4,1	7,3	10,7	14,5	18,3	23,2	29,4
DN125 vertical	min. 7,0 (45 mm)	1,0	4,1	6,9	10,2	14,0	17,7	22,4	27,7
DN160 vertical	min. 8,1 (45 mm)	1,0	4,2	7,1	10,3	14,1	18,0	22,6	28,4

HL62B Roof drain, walkable
HL62.1B Roof drain like HL62B, but with electrical heating
Data

Material	PP, drain body thermal insulated
Outlet	vertical
Extension	PP, 150 x 150 mm, adjustable in length
Sealing flange	PP with stainless steel clamp ring
Inlet	Stainless steel grate, 137 x 137 mm
Standard	EN 1253
Load classification	K3, max. 300 kg
Recommended for	Polymer sheeting, walkable flat roofs
Additional information	Notch dimension: 255 x 380 mm Tap hole dimension: Ø 255 mm

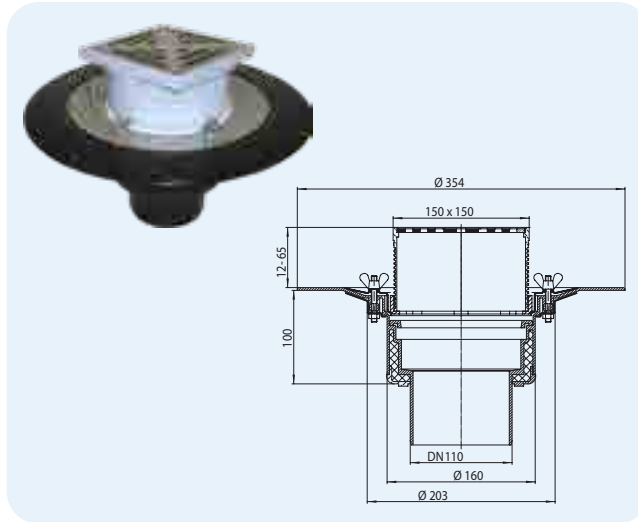

HL62.1B: heated type with self-adjusting heat source for the connection to a 230 V power grid (10 - 30 Watt)

Including Lid cover, 6 pcs. HL062N.4E hex nut alternative to wing nuts

HL-No.	Dimension	Weight	EAN	Piece/package	Type
62B/7	DN75	1803 g	+836253	1	Standard
62.1B/7	DN75	1943 g	+832514	1	with heating
62B/1	DN110	1782 g	+806256	1	Standard
62.1B/1	DN110	1922 g	+802517	1	with heating
62B/2	DN125	1777 g	+816255	1	Standard
62.1B/2	DN125	1917 g	+812516	1	with heating
62B/5	DN160	1811 g	+826254	1	Standard
62.1B/5	DN160	1951 g	+822522	1	with heating

HL62BH Roof drain walkable, with bitumen membrane
HL62.1BH Roof drain like HL62BH, but electrically heated
Data

Material	PP, drain body thermal insulated
Outlet	vertical
Extension	PP, 150 x 150 mm, adjustable in length
Sealing flange	PP, stainless steel, prefabricated welded bitumen membrane
Inlet	Stainless steel grate, 137 x 137 mm
Standard	EN 1253
Load classification	K3, max. 300 kg
Recommended for	Bitumen sheeting; walkable flat roofs
Additional information	Notch dimension: 255 x 380 mm Tap hole dimension: Ø 255 mm

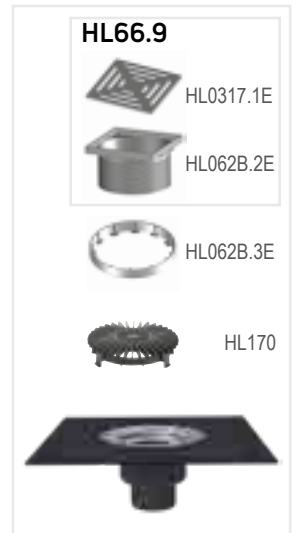
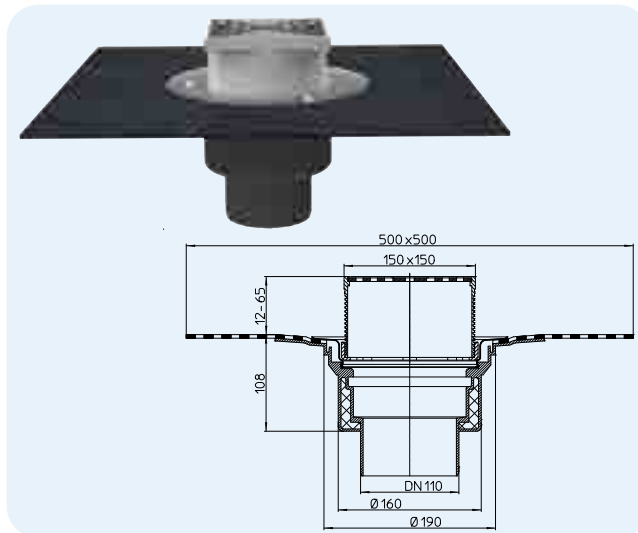

HL62.1BH: heated type with self-adjusting heat source for the connection to a 230 V power grid (10 - 30 Watt)

Including Lid cover

HL-No.	Dimension	Weight	EAN	Piece/package	Type
62BH/7	DN75	2104 g	+846221	1	Standard
62.1BH/7	DN75	2244 g	+802128	1	with heating
62BH/1	DN110	2083 g	+816224	1	Standard
62.1BH/1	DN110	2223 g	+812127	1	with heating
62BH/2	DN125	2078 g	+826223	1	Standard
62.1BH/2	DN125	2218 g	+822126	1	with heating
62BH/5	DN160	2112 g	+836222	1	Standard
62.1BH/5	DN160	2252 g	+832125	1	with heating

Drainage table HL62B, HL62.1B, HL62BH, HL62.1BH
 Tested according to EN 1253-2:2015 according to pt. 5.5.2.1 Fig. 10a) + 10b)
 Drainage capacity tested according to EN 1253-2:2015 according to pt. 5.5.2.1 on downpipe 3 m

Nominal width	EN 1253	5 mm	15 mm	25 mm	35 mm	45 mm	55 mm	65 mm	75 mm
DN75 vertical	min. 1,7 (35 mm)	0,70	1,85	4,60	7,40	10,25	-	-	-
DN110 vertical	min. 4,5 (35 mm)	0,80	1,80	3,70	6,45	9,15	9,35	9,40	9,60
DN125 vertical	min. 7,0 (45 mm)	0,65	1,85	3,65	5,10	6,05	7,75	8,10	8,50
DN160 vertical	min. 8,1 (45 mm)	0,80	2,10	4,20	5,95	6,95	7,50	7,85	8,00

Drainage capacity measured according to EN 1253-2:2015 according to clause 5.5.1.2 free draining

Nominal width	EN 1253	5 mm	15 mm	20 mm	35 mm	45 mm	55 mm	65 mm	75 mm
DN75 vertical	min. 0,8 (35 mm)	0,70	2,00	3,10	3,95	4,10	4,15	4,40	4,45
DN110 vertical	min. 1,4 (35 mm)	0,45	1,80	2,60	3,90	4,55	5,00	5,55	5,90
DN125 vertical	min. 2,8 (45 mm)	0,50	1,65	2,65	3,70	4,20	4,65	5,05	5,40
DN160 vertical	min. 4,0 (45 mm)	0,50	1,75	2,75	3,80	4,20	4,75	5,00	5,40

HL62P Roof drain with PVC-flange

HL62.1P Roof drain like HL62P, but electrically heated

Data

Material	PP, PVC, drain body thermal insulated
Sealing flange	PVC, weldable with hot air
Inlet	Leaf catcher Ø 170 mm
Standard	EN 1253
Recommended for	PVC-sheeting
Additional information	Notch dimension: 170 x 380 mm Tap hole dimension: Ø 170 mm
Including	Lid cover

HL62.1P: heated type with self-adjusting heat source for the connection to a 230 V power grid (10 - 30 Watt)

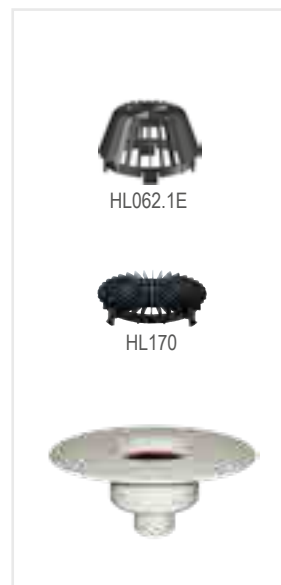
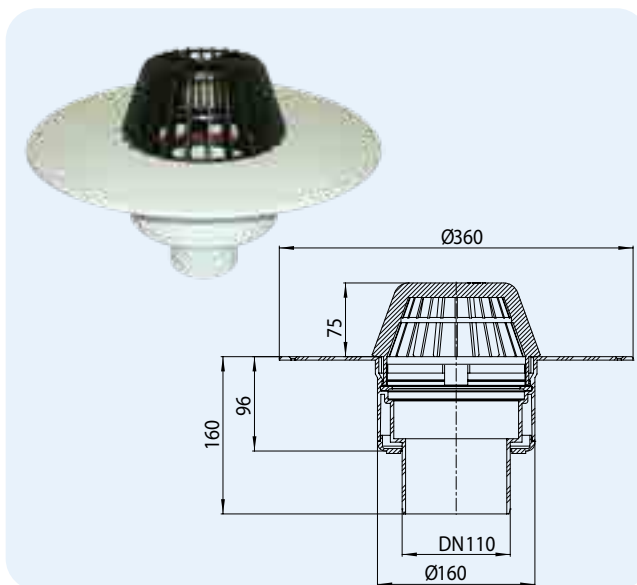

HL-No.	Dimension	Weight	EAN	Piece/package	Type
62P/7	DN75	1307 g	+022144	1	Standard
62.1P/7	DN75	1447 g	+022205	1	with heating
62P/1	DN110	1286 g	+022090	1	Standard
62.1P/1	DN110	1426 g	+021925	1	with heating
62P/2	DN125	1281 g	+022113	1	Standard
62.1P/2	DN125	1421 g	+022168	1	with heating
62P/5	DN160	1315 g	+022120	1	Standard
62.1P/5	DN160	1544 g	+022182	1	with heating

HL62F Roof drain with PP-flange

HL62.1F Roof drain like HL62F, but electrically heated

Data

Material	PP, drain body thermal insulated
Sealing flange	PP, weldable with hot air
Inlet	Leaf catcher Ø 170 mm
Standard	EN 1253
Recommended for	FPO-sheeting, based on PP
Additional information	Notch dimension: 170 x 380 mm Tap hole dimension: Ø 170 mm
Including	Lid cover

HL62.1F: heated type with self-adjusting heat source for the connection to a 230 V power grid (10 - 30 Watt)

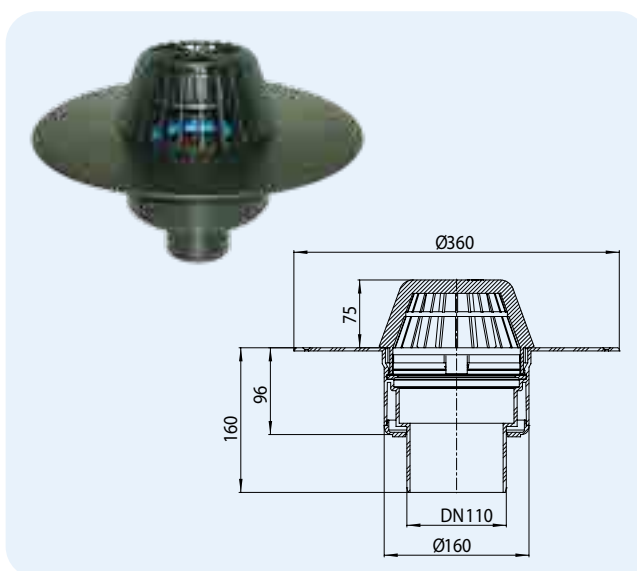

HL-No.	Dimension	Weight	EAN	Piece/package	Type
62F/7	DN75	1307 g	+031740	1	Standard
62.1F/7	DN75	1447 g	+031825	1	with heating
62F/1	DN110	1286 g	+031726	1	Standard
62.1F/1	DN110	1426 g	+031788	1	with heating
62F/2	DN125	1281 g	+031764	1	Standard
62.1F/2	DN125	1421 g	+031801	1	with heating

Drainage table HL62P, HL62.1P, HL62F, HL62.1F

Tested according to EN 1253-2:2015 according to pt. 5.5.2.1 Fig. 10a) + 10b)

Drainage capacity tested according to EN 1253-2:2015 according to pt. 5.5.2.1 on downpipe 3 m

Nominal width	EN 1253	5 mm	15 mm	25 mm	35 mm	45 mm	55 mm	65 mm	75 mm
DN75 vertical	min. 1,7 (35 mm)	0,55	2,30	4,50	7,40	10,60	12,85	16,30	16,30
DN110 vertical	min. 4,5 (35 mm)	0,65	2,50	5,00	7,85	11,45	15,20	19,20	23,60
DN125 vertical	min. 7,0 (45 mm)	0,65	2,50	4,90	7,50	10,75	14,40	18,70	23,10
DN160 vertical	min. 8,1 (45 mm)	0,55	2,55	4,95	7,70	11,10	14,50	18,20	23,60

HL62BP Roof drain with PVC-flange, walkable
HL62.1BP Roof drain like HL62BP, but electrically heated

Data

Material	PP, PVC, drain body thermal insulated
Extension	PP, 150 x 150 mm, adjustable in length
Sealing flange	PVC, weldable with hot air
Inlet	Stainless steel grate, 137 x 137 mm
Standard	EN 1253
Load classification	K3, max. 300 kg
Recommended for	PVC-sheeting, walkable flat roofs
Additional information	Notch dimension: 170 x 380 mm Tap hole dimension: Ø 170 mm

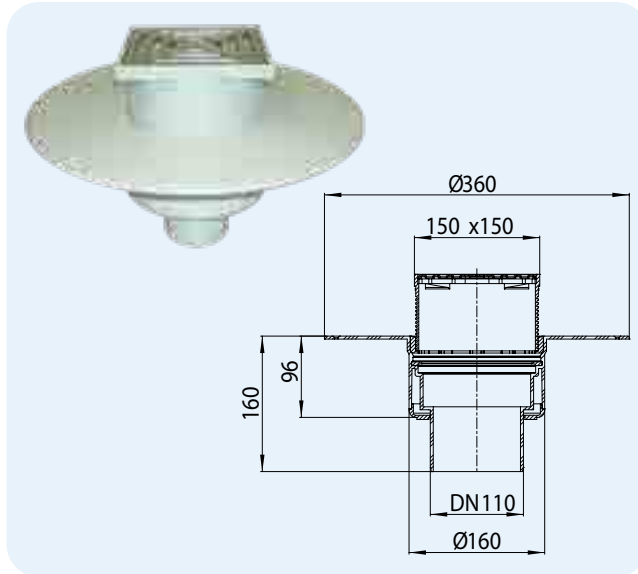

HL66.9



HL62.1BP: heated type with self-adjusting heat source for the connection to a 230 V power grid (10 - 30 Watt)

Including Lid cover

HL-No.	Dimension	Weight	EAN	Piece/package	Type
62BP/7	DN75	1603 g	+022311	1	Standard
62.1BP/7	DN75	1743 g	+022397	1	with heating
62BP/1	DN110	1582 g	+022250	1	Standard
62.1BP/1	DN110	1722 g	+022335	1	with heating
62BP/2	DN125	1577 g	+022274	1	Standard
62.1BP/2	DN125	1717 g	+022359	1	with heating
62BP/5	DN160	1611 g	+022298	1	Standard
62.1BP/5	DN160	1751 g	+022373	1	with heating

HL62BF Roof drain with PP-flange, walkable
HL62.1BF Roof drain like HL62BF, but electrically heated

Data

Material	PP
Extension	PP, 150 x 150 mm, adjustable in length
Sealing flange	PP, weldable with hot air
Inlet	Stainless steel grate, 137 x 137 mm
Standard	EN 1253
Load classification	K3, max. 300 kg
Recommended for	FPO-sheeting, based on PP, walkable flat roofs
Additional information	Notch dimension: 170 x 380 mm Tap hole dimension: Ø 170 mm

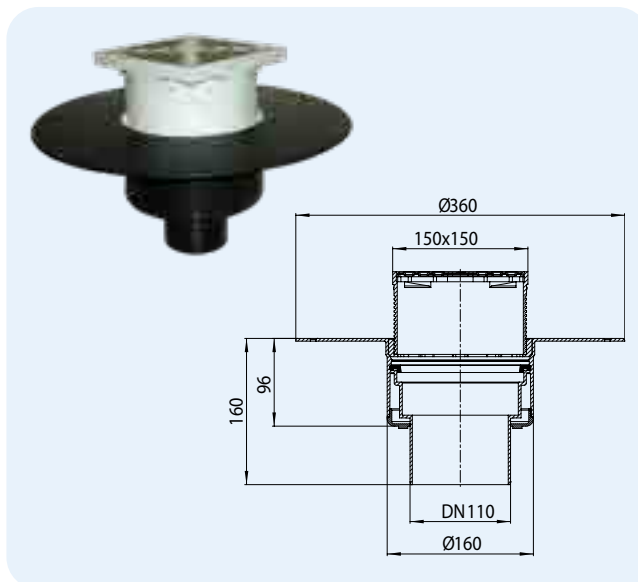

HL66.9



HL62.1BF: heated type with self-adjusting heat source for the connection to a 230 V power grid (10 - 30 Watt)

Including Lid cover

Drainage table HL62BP, HL62.1BP, HL62BF, HL62.1BF

Tested according to EN 1253-2:2015 according to pt. 5.5.2.1 Fig. 10a) + 10b)

Drainage capacity tested according to EN 1253-2:2015 according to pt. 5.5.2.1 on downpipe 3 m

Nominal width	EN 1253	5 mm	15 mm	25 mm	35 mm	45 mm	55 mm	65 mm	75 mm
DN75 vertical	min. 1,7 (35 mm)	0,70	1,85	4,60	7,40	10,25	-	-	-
DN110 vertical	min. 4,5 (35 mm)	0,80	1,80	3,70	6,45	9,15	9,35	9,40	9,60
DN125 vertical	min. 7,0 (45 mm)	0,65	1,85	3,65	5,10	6,05	7,75	8,10	8,50
DN160 vertical	min. 8,1 (45 mm)	0,80	2,10	4,20	5,95	6,95	7,50	7,85	8,00

Drainage capacity measured according to EN 1253-2:2015 according to clause 5.5.1.2 free draining

Nominal width	EN 1253	5 mm	15 mm	20 mm	35 mm	45 mm	55 mm	65 mm	75 mm
DN75 vertical	min. 0,8 (35 mm)	0,70	2,00	3,10	3,95	4,10	4,15	4,40	4,45
DN110 vertical	min. 1,4 (35 mm)	0,45	1,80	2,60	3,90	4,55	5,00	5,55	5,90
DN125 vertical	min. 2,8 (45 mm)	0,50	1,65	2,65	3,70	4,20	4,65	5,05	5,40
DN160 vertical	min. 4,0 (45 mm)	0,50	1,75	2,75	3,80	4,20	4,75	5,00	5,40

HL-No.	Dimension	Weight	EAN	Piece/package	Type
62BF/7	DN75	1603 g	+031344	1	Standard
62.1BF/7	DN75	1743 g	+031849	1	with heating
62BF/1	DN110	1582 g	+031351	1	Standard
62.1BF/1	DN110	1722 g	+031863	1	with heating
62BF/2	DN125	1577 g	+031368	1	Standard
62.1BF/2	DN125	1717 g	+031887	1	with heating

HL64 Roof drain with thermal insulation
HL64.1 Roof drain like HL64, but electrically heated

Data

Material	PP, drain body thermal insulated
Sealing flange	PP with stainless steel clamp ring
Inlet	Leaf catcher Ø 170 mm
Standard	EN 1253
Recommended for	Polymer sheeting
Additional information	Notch dimension: 260 x 380 mm HL64.1: heated type with self-adjusting heat source for the connection to a 230 V power grid (10 - 30 Watt)
Including	Lid cover, 6 pcs. HL062N.4E hex nut alternative to wing nuts

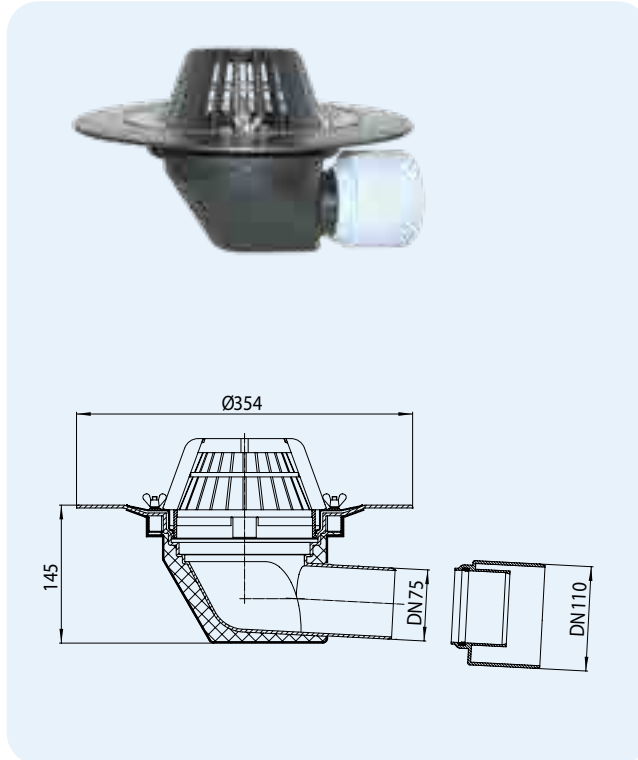

HL-No.	Dimension	Weight	EAN	Piece/package	Type
64	DN75/110	1639 g	+800643	1	Standard
64.1	DN75/110	1781 g	+806416	1	Standard with heating

HL64H Roof drain with bitumen membrane
HL64.1H Roof drain like HL64H, but electrically heated

Data

Material	PP, drain body thermal insulated
Sealing flange	PP, Stainless steel, prefabricated welded bitumen membrane
Inlet	Leaf catcher Ø 170 mm
Standard	EN 1253
Recommended for	Bitumen sheeting
Additional information	Notch dimension: 260 x 380 mm HL64.1H: heated type with self-adjusting heat source for the connection to a 230 V power grid (10 - 30 Watt)
Including	Lid cover

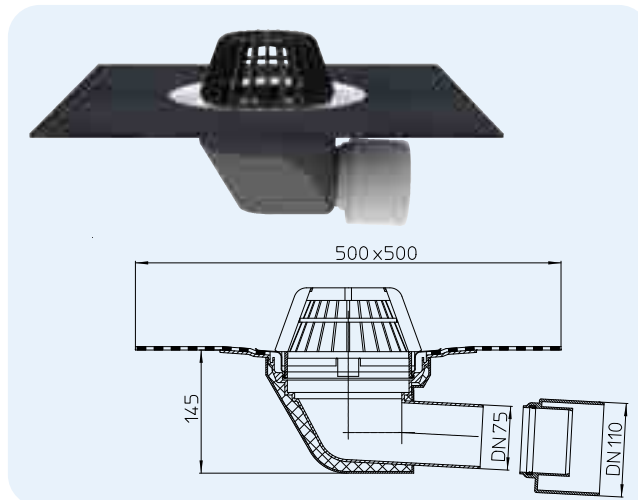

HL-No.	Dimension	Weight	EAN	Piece/package	Type
64H	DN75/110	1953 g	+801640	1	Standard
64.1H	DN75/110	2095 g	+816415	1	Standard with heating

Drainage table HL64, HL64.1, HL64H, HL64.1H
Tested according to EN 1253-2:2015 according to pt. 5.5.2.1 Fig. 10a) + 10b)
Drainage capacity tested according to EN 1253-2:2015 according to pt. 5.5.2.1 on downpipe 3 m

Nominal width	EN 1253	5 mm	15 mm	25 mm	35 mm	45 mm	55 mm	65 mm	75 mm
DN 75 horizontal	min. 1,7 (35 mm)	0,90	3,80	6,00	10,00	13,50	16,50	16,70	16,80
DN 110 horizontal	min. 4,5 (35 mm)	0,90	3,80	5,10	6,00	6,50	6,50	6,50	6,50

HL64B Roof drain walkable
HL64.1B Roof drain like HL64B, but electrically heated
Data

Material	PP, drain body thermal insulated
Extension	PP, 150 x 150 mm, adjustable in length
Sealing flange	PP with stainless steel clamp ring
Inlet	Stainless steel grate, 137 x 137 mm
Standard	EN 1253
Load classification	K3, max. 300 kg
Recommended for	Polymer sheeting, walkable flat roofs
Additional information	Notch dimension: 260 x 380 mm HL64.1B: heated type with self-adjusting heat source for the connection to a 230 V power grid (10 - 30 Watt)
Including	Lid cover, 6 pcs. HL062N.4E hex nut alternative to wing nuts

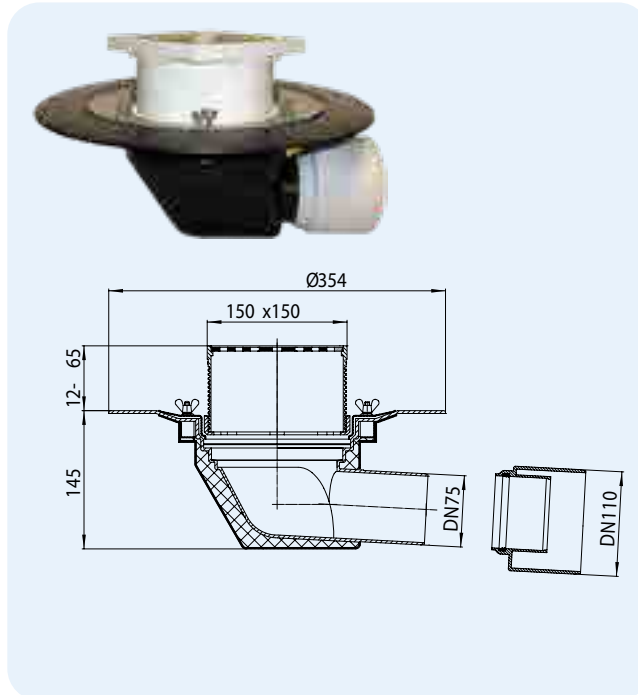
HL66.9

HL-No.	Dimension	Weight	EAN	Piece/package	Type
64B	DN75/110	1900 g	+806423	1	Standard
64.1B	DN75/110	2042 g	+814121	1	with heating

HL64BH Roof drain walkable, with bitumen membrane
HL64.1BH Roof drain like HL64BH, but electrically heated
Data

Material	PP, drain body thermal insulated
Extension	PP, 150 x 150 mm, adjustable in length
Sealing flange	PP, Stainless steel, prefabricated welded bitumen membrane
Inlet	Stainless steel grate, 137 x 137 mm
Standard	EN 1253
Load classification	K3, max. 300 kg
Recommended for	Bitumen sheeting; walkable flat roofs
Additional information	Notch dimension: 260 x 380 mm HL64.1BH: heated type with self-adjusting heat source for the connection to a 230 V power grid (10 - 30 Watt)
Including	Lid cover

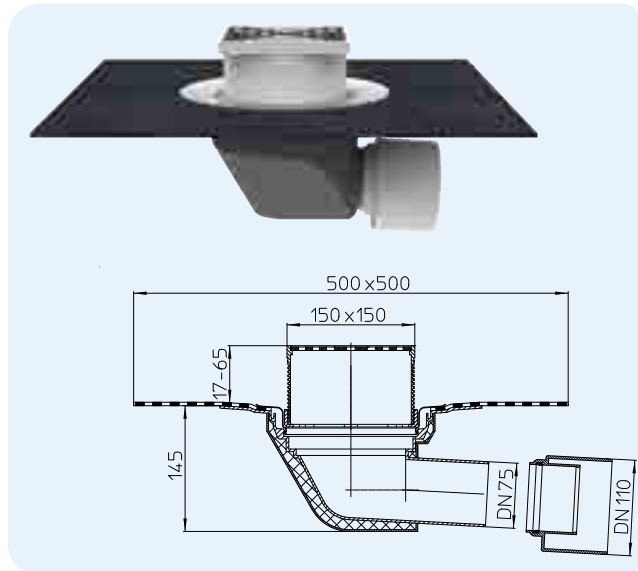
HL66.9

HL-No.	Dimension	Weight	EAN	Piece/package	Type
64BH	DN75/110	2293 g	+816422	1	Standard
64.1BH	DN75/110	2435 g	+864126	1	with heating

Drainage table HL64B, HL64.1B, HL64BH, HL64.1BH

Tested according to EN 1253-2:2015 according to pt. 5.5.2.1 Fig. 10a) + 10b) and pt. 5.5.1.2 Fig. 9

Drainage capacity tested according to EN 1253-2:2015 according to pt. 5.5.2.1 on downpipe 3 m

Nominal width	EN 1253	5 mm	15 mm	25 mm	35 mm	45 mm	55 mm	65 mm	75 mm
DN75 horizontal	min. 1,7 (35 mm)	0,55	1,80	4,00	6,50	9,55	-	-	-
DN110 horizontal	min. 4,5 (35 mm)	0,60	1,90	3,45	3,85	4,15	4,50	4,70	4,80

Drainage capacity measured according to EN 1253-2:2015 according to clause 5.5.1.2 free draining

Nominal width	EN 1253	5 mm	15 mm	20 mm	35 mm	45 mm	55 mm	65 mm	75 mm
DN75 horizontal	min. 0,8 (35 mm)	0,65	1,85	2,95	3,65	3,85	3,90	4,00	4,05
DN110 horizontal	min. 1,4 (35 mm)	0,55	1,80	3,05	3,65	3,85	3,95	4,10	4,15

HL64P Roof drain with PVC-flange
HL64.1P Roof drain like HL64P, but electrically heated

Data

Material	PP, PVC, drain body thermal insulated
Sealing flange	PVC, weldable with hot air
Inlet	Leaf catcher Ø 170 mm
Standard	EN 1253
Recommended for	PVC-sheeting
Additional information	Notch dimension: 260 x 380 mm HL64.1P: heated type with self-adjusting heat source for the connection to a 230 V power grid (10 - 30 Watt)
Including	Lid cover

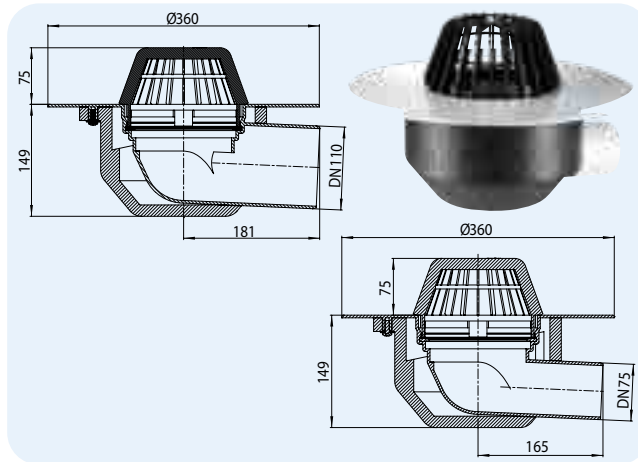

HL-No.	Dimension	Weight	EAN	Piece/package	Type
64P/7	DN75	1739 g	+031405	1	Standard
64.1P/7	DN75	1881 g	+031443	1	with heating
64P/1	DN110	1739 g	+031429	1	Standard
64.1P/1	DN110	1881 g	+031467	1	with heating

HL64F Roof drain with PP-flange
HL64.1F Roof drain like HL64F, but electrically heated

Data

Material	PP, drain body thermal insulated
Sealing flange	PP, weldable with hot air
Inlet	Leaf catcher Ø 170 mm
Standard	EN 1253
Recommended for	FPO-sheeting, based on PP
Additional information	Notch dimension: 260 x 380 mm HL64.1F: heated type with self-adjusting heat source for the connection to a 230 V power grid (10 - 30 Watt)
Including	Lid cover

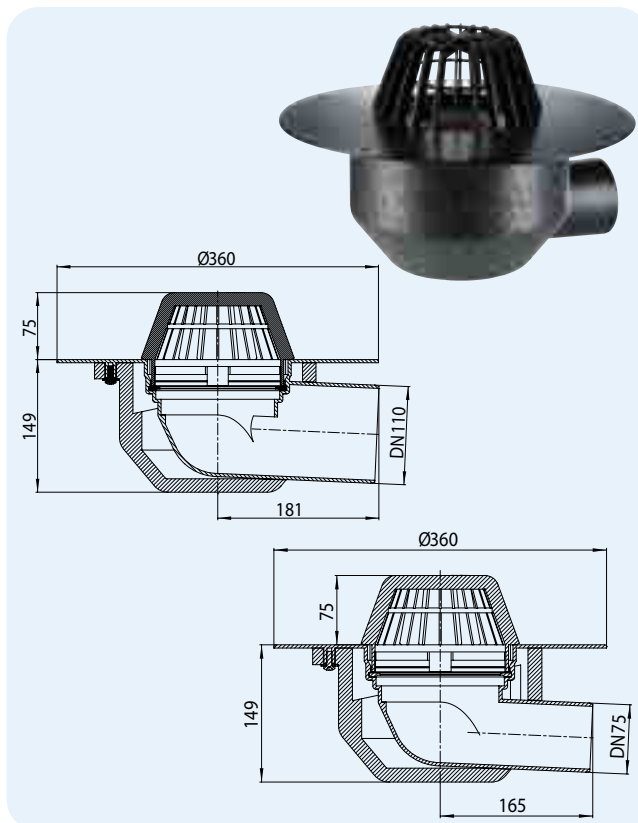

HL-No.	Dimension	Weight	EAN	Piece/package	Type
64F7	DN75	1739 g	+031689	1	Standard
64.1F/7	DN75	1881 g	+031665	1	with heating
64F/1	DN110	1739 g	+031702	1	Standard
64.1F/1	DN110	1881 g	+031641	1	with heating

Drainage table HL64P, HL64.1P, HL64F, HL64.1F

Tested according to EN 1253-2:2015 according to pt. 5.5.2.1 Fig. 10a) + 10b)

Drainage capacity tested according to EN 1253-2:2015 according to pt. 5.5.2.1 on downpipe 3 m

Nominal width	EN 1253	5 mm	15 mm	25 mm	35 mm	45 mm	55 mm	65 mm	75 mm
DN 75 horizontal	min. 1,7 (35 mm)	0,65	2,50	4,40	6,90	10,30	13,60	17,15	17,60
DN 110 horizontal	min. 4,5 (35 mm)	0,60	2,70	5,10	7,80	11,40	15,25	19,40	24,20

HL64BP Roof drain with PVC-flange, walkable
HL64.1BP Roof drain like HL64BP, but electrically heated

Data

Material	PP, PVC, drain body thermal insulated
Extension	PP, 150 x 150 mm, adjustable in length
Sealing flange	PVC, weldable with hot air
Inlet	Stainless steel grate, 137 x 137 mm
Standard	EN 1253
Load classification	K3, max. 300 kg
Recommended for	PVC-sheeting, walkable flat roofs
Additional information	Notch dimension: 260 x 380 mm HL64.1BP: heated type with self-adjusting heat source for the connection to a 230 V power grid (10 - 30 Watt)

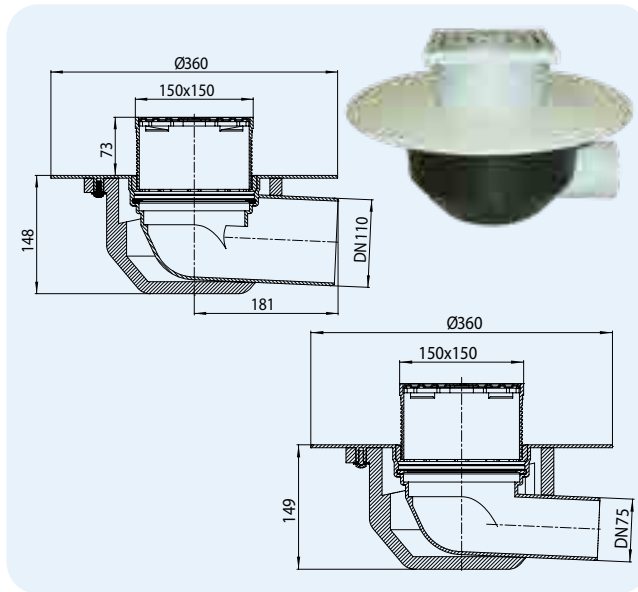

Including	Lid cover
-----------	-----------

HL-No.	Dimension	Weight	EAN	Piece/package	Type
64BP/7	DN75	2000 g	+031481	1	Standard
64.1BP/7	DN75	2142 g	+031566	1	with heating
64BP/1	DN110	2000 g	+031504	1	Standard
64.1BP/1	DN110	2142 g	+031542	1	with heating

HL64BF Roof drain with PP-flange, walkable
HL64.1BF Roof drain like HL64BF, but electrically heated

Data

Material	PP, drain body thermal insulated
Extension	PP, 150 x 150 mm, adjustable in length
Sealing flange	PP, weldable with hot air
Inlet	Stainless steel grate, 137 x 137 mm
Standard	EN 1253
Load classification	K3, max. 300 kg
Recommended for	FPO-sheeting, based on PP, walkable flat roofs
Additional information	Notch dimension: 260 x 380 mm HL64.1BF: heated type with self-adjusting heat source for the connection to a 230 V power grid (10 - 30 Watt)

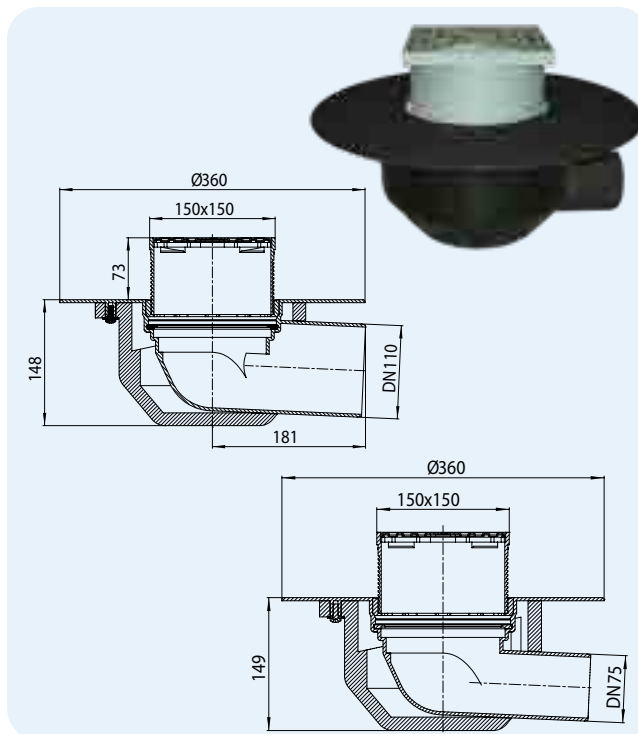

Including	Lid cover
-----------	-----------

HL-No.	Dimension	Weight	EAN	Piece/package	Type
64BF/7	DN75	2000 g	+031603	1	Standard
64.1BF/7	DN75	2142 g	+031566	1	with heating
64BF/1	DN110	2000 g	+031627	1	Standard
64.1BF/1	DN110	2142 g	+031580	1	with heating

Drainage table HL64BP, HL64.1BP, HL64BF, HL64.1BF
 Tested according to EN 1253-2:2015 according to pt. 5.5.2.1 Fig. 10a) + 10b) and pt. 5.5.1.2 Fig. 9
 Drainage capacity tested according to EN 1253-2:2015 according to pt. 5.5.2.1 on downpipe 3 m

Nominal width	EN 1253	5 mm	15 mm	25 mm	35 mm	45 mm	55 mm	65 mm	75 mm
DN75 horizontal	min. 1,7 (35 mm)	0,55	1,80	4,00	6,50	9,55	-	-	-
DN110 horizontal	min. 4,5 (35 mm)	0,60	1,90	3,45	3,85	4,15	4,50	4,70	4,80

Drainage capacity measured according to EN 1253-2:2015 according to clause 5.5.1.2 free draining

Nominal width	EN 1253	5 mm	15 mm	20 mm	35 mm	45 mm	55 mm	65 mm	75 mm
DN75 horizontal	min. 0,8 (35 mm)	0,65	1,85	2,95	3,65	3,85	3,90	4,00	4,05
DN110 horizontal	min. 1,4 (35 mm)	0,55	1,80	3,05	3,65	3,85	3,95	4,10	4,15

HL64HPower Power roof drain with bitumen flange
HL64PPower Power roof drain with PVC-flange
HL64FPower Power roof drain with PP-flange

Data

Material	HL64HPower: PP, bitumen HL64PPower: PP, PVC HL64FPower: PP, PP
Flange	HL64HPower: Pre-mounted bitumen membrane HL64PPower: Fixed PVC-flange for hot air HL64FPower: Fixed PP-flange for hot air
Inlet	Crewed leaf catcher diameter 240mm
Standard	EN 1253
Recommended for	Installation in thermo-insulations min. 120mm, high capacity alternative for attica drains
Additional information including	Notch dimension 180mm x 260mm Lid cover

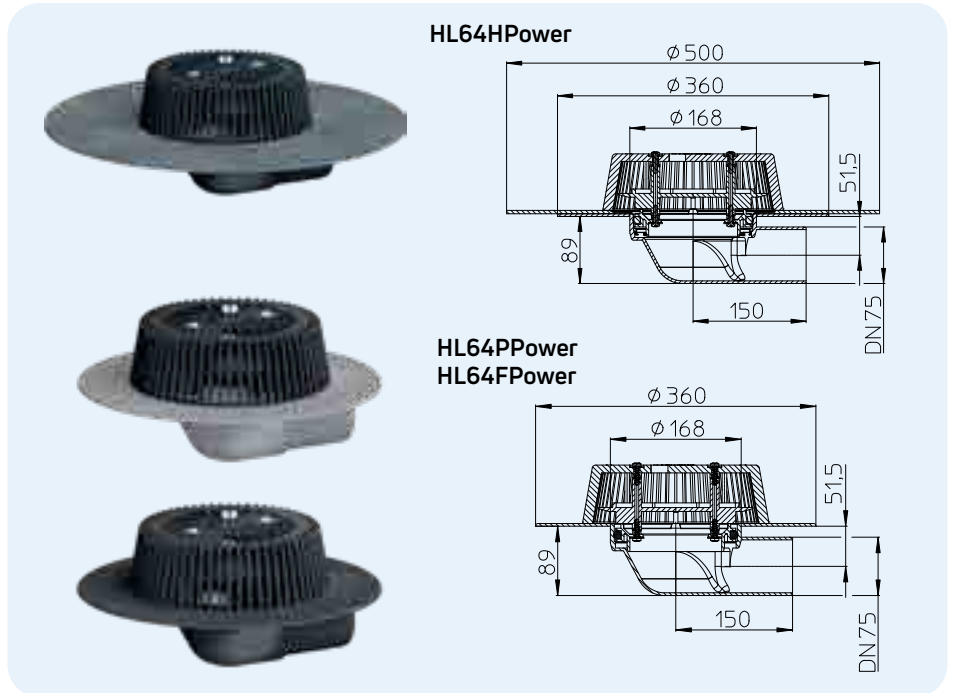

Drainage table HL64HPower, HL64PPower, HL64FPower

Tested according to EN 1253-2:2015 according to pt. 5.5.2.1 Fig. 10a) + 10b)
 Drainage capacity tested according to EN 1253-2:2015 according to pt. 5.5.2.1 on downpipe 3 m

Nominal width	EN 1253	5 mm	15 mm	25 mm	35 mm	45 mm	55 mm	65 mm	75 mm
DN 75 horizontal	min. 1,7 (35 mm)	0,70	3,20	7,30	12,00	15,60	16,00	16,00	

HL-No.	Dimension	Weight	EAN	Piece/package
64HPower	DN75	3817 g	+040797	1
64PPower	DN75	2920 g	+040810	1
64FPower	DN75	2646 g	+040780	1

HL69 Roof renovation drain

Data

Material	PP
Sealing flange	PP with stainless steel clamp ring
Inlet	Leaf catcher Ø 170 mm
Recommended for	Polymer sheeting; for the simple and quick renovation of the old drainage system
Additional information	Easily to be plugged into the body of the old drain with vertical outlet - ready installed. Fits exactly into the old pipes with the prefabricated lip-gaskets.
Including	Lid cover, 6 pcs. HL062N.4E hex nut alternative to wing nuts

Gasketdiameter min. / max.		
Roof drain	Ø min.	Ø max.
HL69	Gasket	Gasket
DN75	64 mm	73,5 mm
DN110	100 mm	108 mm
DN125	105 mm	123 mm
DN160	145 mm	159 mm

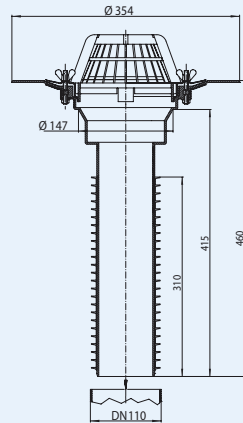

HL-No.	Dimension	Weight	EAN	Piece/package
69/7	for DN75	1523 g	+000580	1
69/1	for DN110	1781 g	+004515	1
69/2	for DN125	1877 g	+004522	1
69/5	for DN160	2265 g	+008261	1

HL69H Roof renovation drain with bitumen membrane

Data

Material	PP
Sealing flange	PP, prefabricated welded bitumen membrane
Inlet	Leaf catcher Ø 170 mm
Recommended for	Bitumen sheeting; for the simple and quick renovation of the old drainage system
Additional information	Easily to be plugged into the body of the old drain with vertical outlet - ready installed. Fits exactly into the old pipes with the prefabricated lip-gaskets.
Including	Lid cover

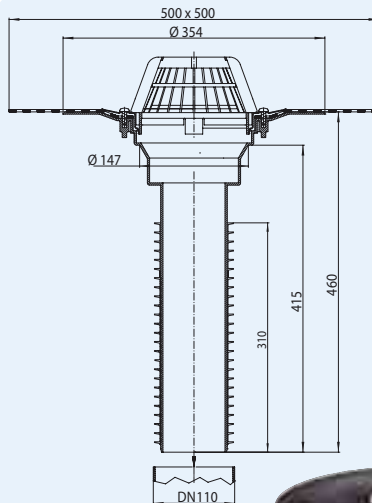

Gasketdiameter min. / max.		
Roof drain	Ø min.	Ø max.
HL69	Gasket	Gasket
DN75	64 mm	73,5 mm
DN110	100 mm	108 mm
DN125	105 mm	123 mm
DN160	145 mm	159 mm



Drainage table HL69, HL69H

Tested according to EN 1253-2:2015 according to pt. 5.5.2.1 Fig. 10a) + 10b)

Drainage capacity tested according to EN 1253-2:2015 according to pt. 5.5.2.1 on downpipe 3 m

Nominal width	EN 1253	5 mm	15 mm	25 mm	35 mm	45 mm	55 mm	65 mm	75 mm
DN75 vertical	min. 1,7 (35 mm)	0,80	3,60	6,80	9,70	12,90	13,30	13,50	13,60
DN110 vertical	min. 4,5 (35 mm)	0,90	3,90	6,90	9,60	12,50	15,50	17,50	22,30
DN125 vertical	min. 7,0 (45 mm)	0,90	4,30	7,50	10,90	14,20	18,50	23,00	24,30
DN160 vertical	min. 8,1 (45 mm)	1,00	4,30	7,40	10,70	15,00	19,00	22,70	29,80

HL-No.	Dimension	Weight	EAN	Piece/package
69H/7	für DN75	2074 g	+004539	1
69H/1	für DN110	2332 g	+004546	1
69H/2	für DN125	2428 g	+004553	1
69H/5	für DN160	2816 g	+008285	1

HL69P Roof renovation drain with PVC-flange

Data

Material	PP, PVC
Sealing flange	PVC , weldable with hot air
Inlet	Leaf catcher Ø 170 mm
Recommended for	PVC-sheeting; for the simple and quick renovation of the old drainage system.
Additional information	Easily to be plugged into the body of the old drain with vertical outlet - ready installed. Fits exactly into the old pipes with the prefabricated lip-gaskets.
Including	Lid cover

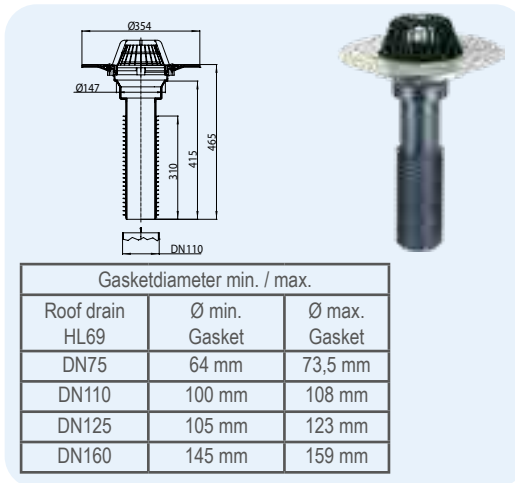

HL-No.	Dimension	Weight	EAN	Piece/package
69P/7	for DN75	2103 g	+022663	1
69P/1	for DN110	2461 g	+022601	1
69P/2	for DN125	2557 g	+022625	1
69P/5	for DN160	2845 g	+022649	1

HL80.3 Roof drain with continuously variable outlet

Data

Material	PP, PE
Connection dimension	DN50/75 crosscutable
Outlet	convertable from horizontal to vertical, Material PE, pluggable and weldable
Inlet	Leaf catcher Ø 110 mm
Standard	EN 1253
Recommended for	Roof areas up to 33 m ² and rain yield factor of 300 l / (s x ha)
Additional information	Tap hole dimension Ø 185 mm
Including	Lid cover

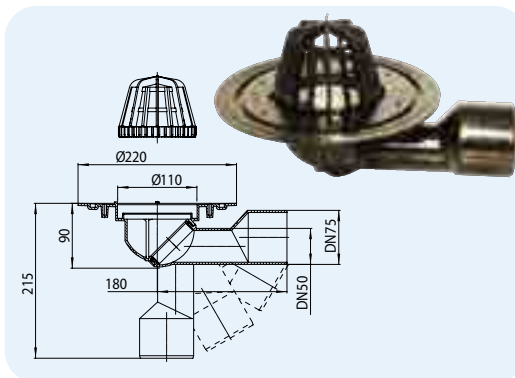

HL-No.	Dimension	Weight	EAN	Piece/package
80.3	DN50/75	550 g	+908035	1

HL80.3H Roof drain with continuously variable outlet and bitumen membrane

Data

Material	PP
Connection dimens.	DN50/75 adjustable in length
Outlet	convertable from horizontal to vertical, Material PE, pluggable and weldable
Sealing flange	PP, prefabricated welded bitumen membrane
Inlet	Leaf catcher Ø 110 mm
Standard	EN 1253
Recommended for	Bitumen sheeting, Roof areas up to 33 m ² and rain yield factor of 300 l / (s x ha)
Additional information	Tap hole dimension Ø 185 mm
Including	Lid cover

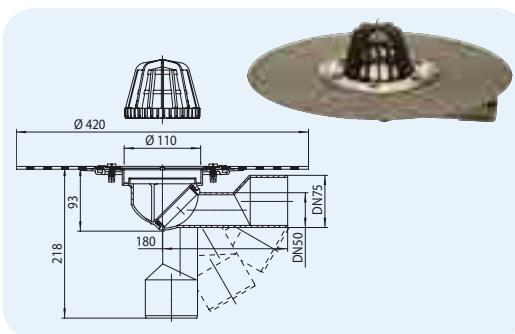

HL-No.	Dimension	Weight	EAN	Piece/package
80.3H	DN50/75	550 g	+918034	1

Drainage table HL69P

Tested according to EN 1253-2:2015 according to pt. 5.5.2.1 Fig. 10a) + 10b)
Drainage capacity tested according to EN 1253-2:2015 according to pt. 5.5.2.1 on downpipe 3 m

Nominal width	EN 1253	5 mm	15 mm	25 mm	35 mm	45 mm	55 mm	65 mm	75 mm
DN75 vertical	min. 1,7 (35 mm)	0,80	2,70	4,90	7,90	11,00	13,30	13,50	13,60
DN110 vertical	min. 4,5 (35 mm)	0,80	2,80	5,10	8,10	11,70	15,50	19,00	23,90
DN125 vertical	min. 7,0 (45 mm)	0,80	2,80	5,20	8,30	11,80	15,50	19,50	24,00
DN160 vertical	min. 8,1 (45 mm)	0,80	2,50	5,00	8,00	11,30	14,80	18,90	23,70

Drainage table HL80.3, HL80.3H

Tested according to EN 1253-2:2015 according to pt. 5.5.2.1 Fig. 10a) + 10b) and pt. 5.5.1.2 Fig. 9
Drainage capacity tested according to EN 1253-2:2015 according to pt. 5.5.2.1 on downpipe 3 m

Nominal width	EN 1253	5 mm	15 mm	25 mm	35 mm	45 mm	55 mm	65 mm	75 mm
DN 50	min. 0,9 (35 mm)	0,65	1,25	1,35	4,80	6,15	6,30	6,35	6,40
DN75	min. 1,7 (35 mm)	0,55	1,45	2,50	2,80	-	-	-	-

Drainage capacity measured according to EN 1253-2:2015 according to clause 5.5.1.2 free draining

Nominal width	EN 1253	5 mm	15 mm	20 mm	35 mm	45 mm	55 mm	65 mm	75 mm
DN 50	min. 0,8 (20 mm)	0,35	1,45	1,50	1,55	1,60	1,70	1,75	1,80
DN75	min. 0,8 (20 mm)	0,50	1,35	1,60	1,80	1,95	2,00	2,10	2,20

HL65 Extension

Data

Material	PP
Connection dimension	DN125
Outlet	vertical
Sealing flange	PP with stainless steel clamp ring
Recommended for	Polymer sheeting; fits to HL62(.1)(H), HL64(.1)(H)
Additional information	incl. backflow gasket
Including	6 pcs. HL062N.4E hex nut alternative to wing nuts

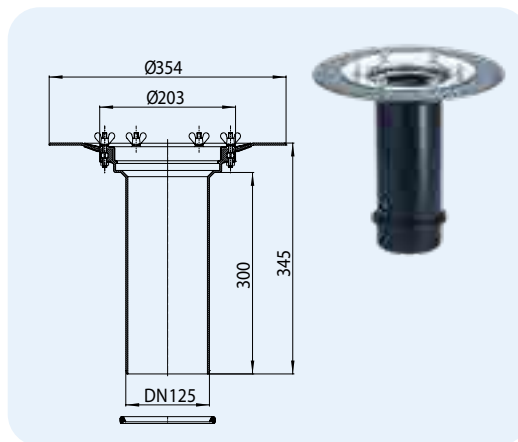

HL-No. 65	Weight 1438 g	EAN +800650	Piece/package 1
--------------	------------------	----------------	--------------------

HL65H Extension with bitumen membrane

Data

Material	PP
Connection dimension	DN125
Outlet	vertical
Sealing flange	PP, prefabricated welded bitumen membrane
Recommended for	Bitumen sheeting
Additional information	incl. backflow gasket

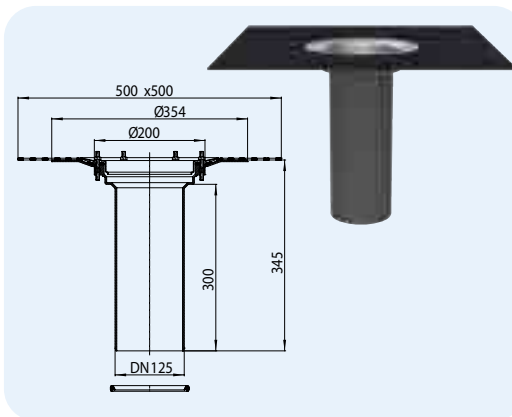

HL-No. 65H	Weight 2137 g	EAN +801657	Piece/package 1
---------------	------------------	----------------	--------------------

HL65P Extension with PVC-flange

Data

Material	PVC
Connection dimension	DN125
Outlet	vertical
Sealing flange	PVC, weldable with hot air
Recommended for	PVC-sheeting
Additional information	incl. backflow gasket

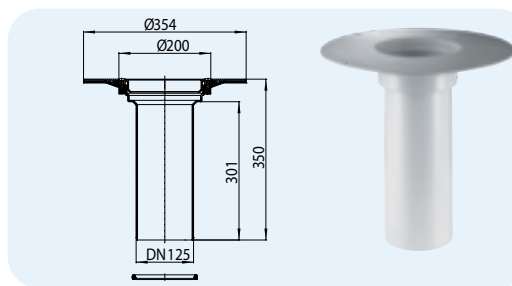

HL-No. 65P	Weight 1338 g	EAN +022588	Piece/package 1
---------------	------------------	----------------	--------------------

HL65F Extension with PP-flange HL65PE Extension with PE-flange

Data

Material	HL65F: PP HL65PE: PE
Connection dimension	DN125
Outlet	vertical
Sealing flange	PP resp. PE, weldable by hot air
Recommended for	HL65F: FPO-sheeting, based on PP HL65PE: FPO-sheeting, based on PE
Additional information	incl. backflow gasket

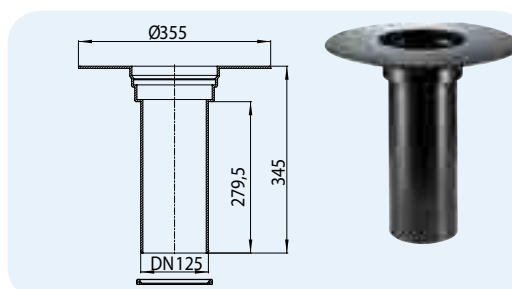

HL-No. 65F 65PE	Weight 1338 g 1600 g	EAN +031900 +017126	Piece/package 1 1
-----------------------	----------------------------	---------------------------	-------------------------

HL Roof drains – Accessories – Data

HL635N Drainage and inspection chamber for green, gravel and terrace roofs

HL635N.0 Drainage and inspection chamber for green, gravel and terrace roofs, without grate

Data

Installation height	70 -205 mm
Material	EPP/PP
Dimensions	frame outer dimensions: 390 x 390 mm inlet grate: 368 x 368 x 25 mm, 4 x screwed, part can be cut to length: Ø 350 mm
Load class	plastic inlet grate K3 (300 kg)
Standard	DIN 1986-3
Additional information	For easy inspection and maintenance of roof drains on green, gravel and terrace roofs

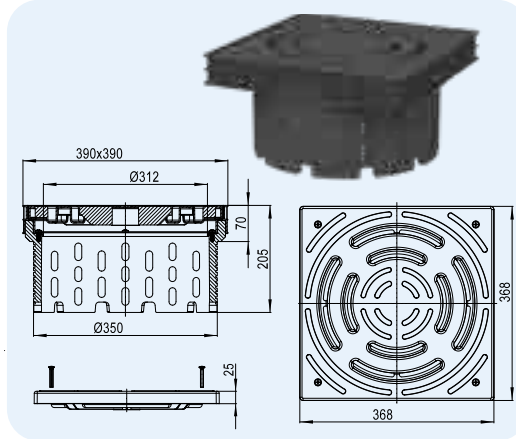

HL-No. 635N	Weight 2151 g	Grate with	EAN +032228	Piece/package 1
635N.0	1178 g	without	+032389	1

HL636N Extension element for drainage and inspection chamber HL635N

Data

Installation height	25 - 150 mm
Material	EPP
Dimensions	See tech. Drawing
Standard	DIN 1986-3
Additional information	For extension of the drainage and inspection chamber HL635N. The chamber can be extended to any length by connecting two or more extension elements.

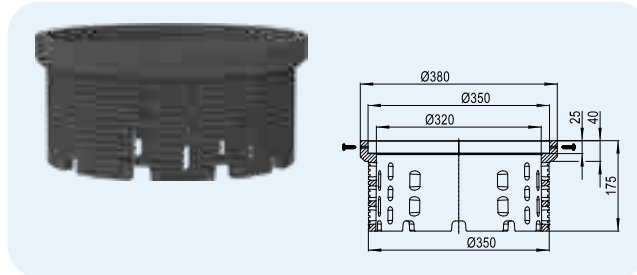

HL-No. 636N	Weight 600 g	EAN +032396	Piece/package 1
----------------	-----------------	----------------	--------------------

HL0635N.2 Galvanized steel grating for drainage and inspection chamber HL635N.0

Data

Material	Galvanized sheet steel
Dimensions	368 x 368 x 25 mm
Load class	L15 or A15 - max 1,5 t
Additional information	For surfaces with high load demands

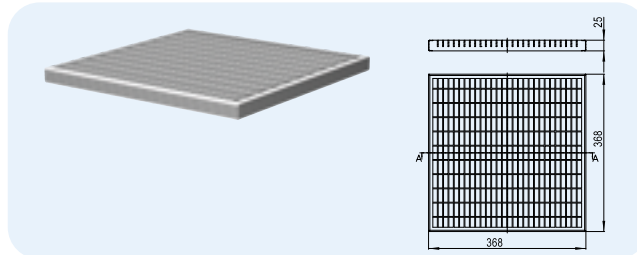

HL-No. 635N.2	Weight 3000 g	EAN +006199	Piece/package 1
------------------	------------------	----------------	--------------------

HL0635N.3 Closed plastic lid for drainage and inspection chamber HL635N.0

Data

Material	PP (polypropylene)
Dimensions	368 x 368 x 25 mm, 4 x screwable
Load class	K3 (300 kg)
Additional information	Specially designed for retention roofs with rain retention



HL-No. 635N.3	Weight 1013 g	EAN +007202	Piece/package 1
------------------	------------------	----------------	--------------------

HL160 Gravel guard for inverted roofs

Data

Material PP

Additional information for installation between drain flange and extension, to drain enough water in the second drainage level, e.g. inverted roofs. Fits to drain series HL62, HL63, HL64, HL69 and extension HL350(.0)

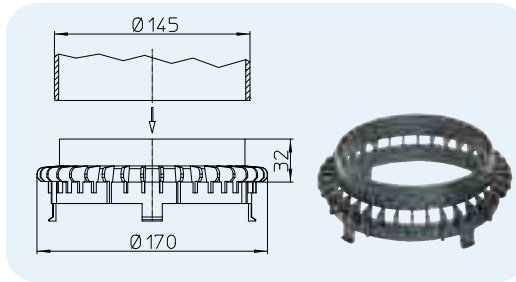

HL-No.	Dimension	Weight	EAN	Piece/Package
160	Ø 170 mm	53 g	+001606	1

HL161 Drainage element for series HL65

Data

Material PP

Additional information for installation between drain flange and extension HL65-series, to drain water on the second drainage level or on the vapour barrier, e.g. at aered roofs. Fits to drain series HL62, HL63, HL64, HL69 and extension HL65.

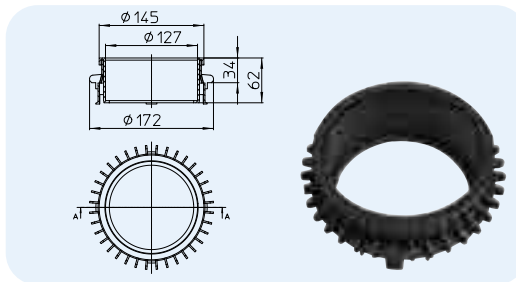

HL-No.	Dimension	Weight	EAN	Piece/Package
161	Ø 172 mm	134 g	+034772	1

HL175 Stainless steel leaf catcher

Data

Material Stainless steel 1.4301

Additional information Fits to all HL roof drains and extensions

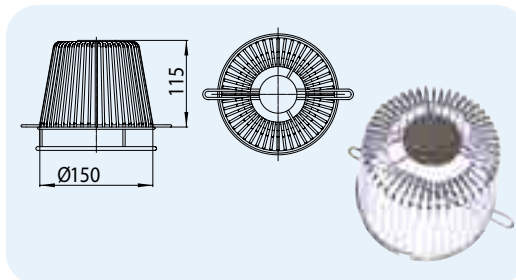

HL-Nr.	Dimension	Weight	EAN	Piece/Package
175	Ø 150 mm	520 g	+018031	1

HL603 Flap seal for external downpipes

Data

Capacity DN110 and DN160: 6l/s

Material PP

Connection HL603/1: DN110
HL603/5: DN160

Outlet HL603/1: DN110
HL603/5: DN160

Recommended for Avoids stench, coming up the downpipe, e.g. for roof drains, which are connected to the sewer

Additional information Only for vertical installation, care for access for cleaning!

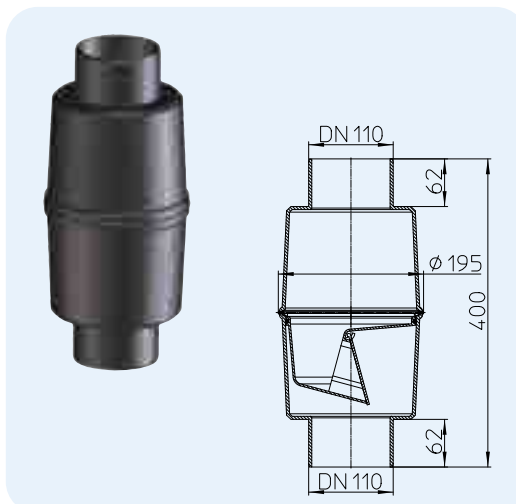

HL-Nr.	Dimension	Weight	EAN	Piece/Package
603/1	DN110	940 g	+005956	1
603/5	DN160	940 g	+011933	1

35-75

500 x 500
Ø 262

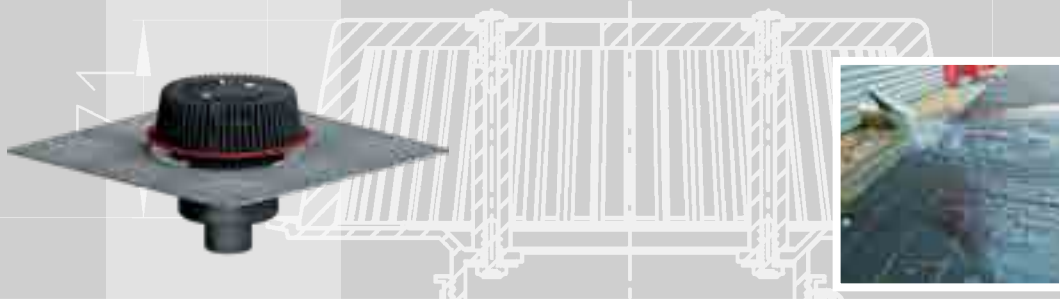

HL Safety drainage

Ø 354

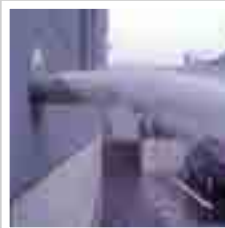

Basic information on planning and implementation

• Why do I need safety drains?

Basically rain water on flat roofs is being lead away by roof gullies. Either as conventional gravity drainage or as vacuum roof drainage. The dimensioning and planning is based on an average 5-year rainfall intensity ($l/(s \cdot ha)$). Should the rainfall exceed the previous mentioned base (because of higher rain intensity during a 100 year rain event), rain water will not be drained anymore. In that case an independent safety drain should be installed, in order to reliably lead off the coming up rainfall.

The safety drain covers exceptional events like this and protects the roof construction (including any connected structural damage). Usually those thoughts are being neglected by the relevant/responsible people. Should a safety drain be undersized or not even be installed during an extraordinary rain event it can lead to an increase of the water level on the roof surface. For example pulling up of the sealing. The seeping in of water follows and leads to hidden damages and enormous repair costs. Not even to talk about the worst case scenario: break down of the roof construction!

• Where do I find the regulations for planning and implementation of a safety drain?

In Austria there is a regulation called ÖNORM B 2501, also EN..... ÖNORM B 2501, Extracts:

5.10 Drainage of roofs and site areas

5.10.1 Rated rainfall intensity

Usually the roof drainage is based on a 5-minute rain event with a return frequency of 5 years. The calculated rain fall intensity, with respect to the relevant location, can be taken from the data of the Federal Ministry of Agriculture and Forestry, Environment and Water Management under <http://ehyd.gv.at> (parameters and measurements). They have to be recalculated to $l/(s \cdot ha)$.

The minimum rainfall intensity for roof surfaces and site areas is being set at $300 l/(s \cdot ha)$.

The measurement of the roof drainage is made according to ÖNORM EN 12056-3:2000, part 4.1.
Same approach for property drainage.

5.10.5.1 Safety overflow, safety drains

5.10.5.1 General information

Roofs and terraces with inward drainage, in addition to each single individual area (for a rain intensity according to 5.10.1) should be provided with an emergency overflow and drainage. The goal is to cover a minimum sum of all individual areas according to 5.10.2. Should a roof or terrace surface be established with more than two outlets each, it is possible to dimension one or more of the partial surfaces as a safety drain. Within buildings, safety drains are to be drained separate to the roof drainage (according to 5.10.1). While positioning the safety drains, the existing connection heights of the rising components and, if needed, the necessary accumulation height of the drainage system, have to be taken into consideration.

The safety drain must never be connected to any wastewater pipes.

Exceptions are: existing buildings, where the roof drainage had and has to be lead into a mixed water pipe. A mathematical prove of the system performance must be made. The drainage system as well as the safety overflow and drain system are supposed to work together and provide a drainage, concerning an expected 5 minute rain event with a return frequency of a 100 years $r(5,100)$

• How do I calculate the minimum flow of a safety drain?

Based on an example, we would like to show you how to calculate your safety drain system. Please note the following:

Basic Details



Building Location: Himberg bei Wien

Roof Dimensions: 55 m x 20 m

Roof Surface: 1100 m²

Type of Roof: Flat Roof with attic, slope: 2%

Allowed Roof Load / Snow Load: 0,884 kN/m²

Calculation factor from kN/m² to mm water column = 101,974 428 892 2

Maximum water level on the roof: 90,14 mm

The roof drainage is to be used as vacuum drainage. It is designed to cover a 5 minute rain event.

Water output values of the roof drains are being checked for gravity drainage according to EN1253-2:2015 (table 3) to DN110 with a 35 mm and DN125 + DN150 with 45 mm water level.

For a drainage with pressure flow the water level is to be set to a height of 55mm.

Rated rainfall intensity is based on the data of <http://ehyd.gv.at> for a 5 minute rain event with the following return frequency $r_{(5,5)} = 446,66 \text{ l/(s} \cdot \text{ha)}$

The return frequency for a 5 minute rain event during an average of 100 years has been set to $r_{(5,100)} = 836,66 \text{ l/(s} \cdot \text{ha)}$

The minimum flow of the emergency drainage is to be calculated as the following:

$$Q_{\text{not}} = (r_{(5,100)} - r_{(5,5)} \cdot C) \cdot \frac{A}{10000}$$

Q_{not} Minimum run-off capacity of the emergency drainage in l/s

$r_{(5,100)}$ 5 minutes-rain event in l/(s·ha) with an interval of recurrence of 100 years = **836,66 l/(s · ha)**

$r_{(5,5)}$ 5 minutes-rain event in l/(s·ha) with an interval of recurrence of 5 years = **446,66 l/(s · ha)**

C Run-off coefficient (without dimension) depending on the roof surface condition = **1**

A Effective roof surface in m² = **1100 m²**

$$Q_{\text{not}} = (836,66 - 446,66 \cdot 1) \cdot 0,11 = \mathbf{42,9 \text{ l/s}}$$

• What safety drains should be used?

Basically there are a few different technical solutions to ensure any safety drainage. The decision primarily will be taken by the planner. Following you will find 4 different possibilities to implement a safety drain, according to the example on page 3.

Example 1: Rectangular safety overflow via the attic

Calculation of the overflow with according to ÖNORM 2501 and DIN 1986-100

Overflow Volume (l/s)	42,9
Allowed Roof Load (kN/m ²)	0,884
Maximum Water Level (mm)	90,14
Water Level of roof outlets (mm)	55
Overflow height (mm)	35,14



$$Q_w = \frac{L_w \cdot h_{\ddot{u}}^{1,5}}{24\,000} \quad \text{bzw.} \quad L_w = \frac{Q_w \cdot 24\,000}{h_{\ddot{u}}^{1,5}}$$

- Q_w Drain capacity per meter length in l/s,
- L_w Length of the overflow in mm
- $h_{\ddot{u}}$ Maximum planned water level in case of overflow (pressure height) in mm

$$L_w = \frac{42,9 \text{ l/s} \cdot 24\,000}{h_{\ddot{u}}^{1,5}} = 4942,72 \text{ mm} = 4,95 \text{ m}$$

For this example the necessary overflow width was calculated on a base of 4,95 m. Should the slit width be set to 500 mm (as usual), the roof surface will have to be provided with 10 attic outlets, 5 on each of the two longer sides.

Necessary outlets: **10**

Example 2: Round safety overflow as water spout via the attic

Overflow Volume (l/s): 42,9 l/s
 The drain capacity of a round DN 100 opening with a 35 mm water level and an inclination of 5° is **1 l/s**.
 Please see ÖNORM B2501 as pointed out in

Necessary outlets: **44**



Example 3: Safety drain close to the attic (HL PowerSafe) connected to a 3m down pipe

The drain capacity of the HL PowerSafe system, connected to a 3m down pipe and a water level of 35mm is set to 12 l/s.

Requirement to the safety drainage: 42,9 l/s

Performance of 4 PowerSafe drains: 48 l/s

Necessary outlets: 4

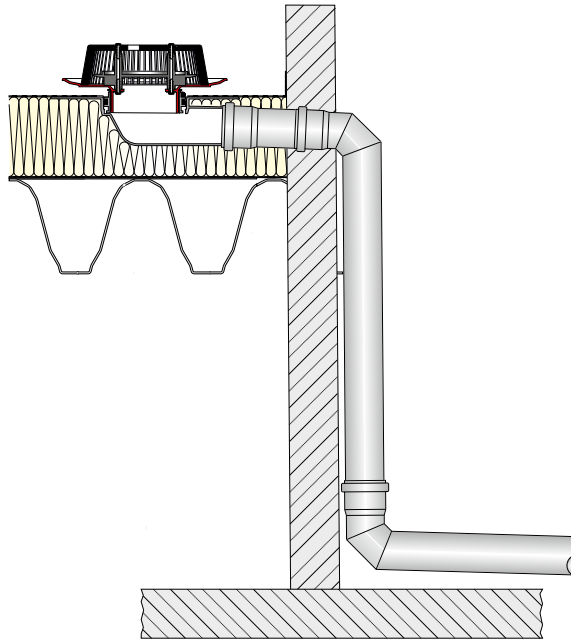

Example 4: Safety drain close to the attic (HL PowerSafe) including extension element

The drain capacity of the HL PowerSafe DN110, connected according to the picture presuming a water level of 35 mm is set to 8,1 l/s.

Requirement to the safety drainage: 42,9 l/s

Performance of 6 PowerSafe drains: 48,6 l/s

Necessary outlets: 6

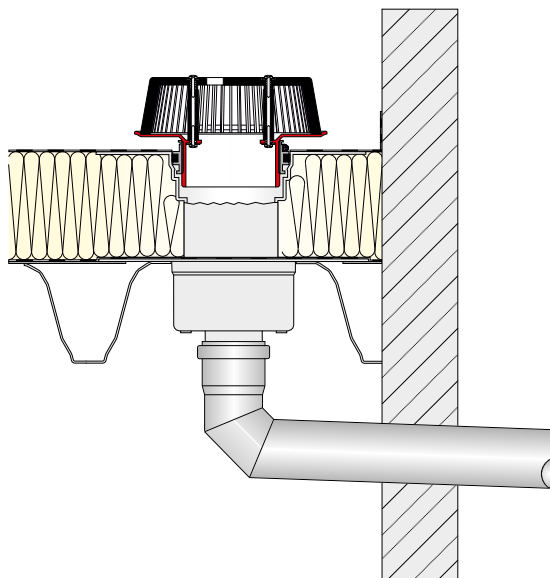

HL Roof Drains – Products – Overview

Drains



Product	HL62Safe	HL62HSafe	HL62PSafe	HL62FSafe	HL64Safe	HL64HSafe
Description	Safety roof drain Vertical with clamping ring	Safety roof drain Vertical with bitumen membrane	Safety roof drain Vertical with PVC sealing flange	Safety roof drain Vertical with PP sealing flange	Safety roof drain Horizontal with clamping flange	Safety roof drain Horizontal with bitumen membrane
Function	Clamping of polymeric roof seal strips	Special design for connection to bitumen seals	Special design for connection to PVC seal strips	Special design for con- nection to PP-based FPO seal strips	Clamping of polymeric roof seal strips	Special design for connection to bitumen seals

Drains



Product	HL64PSafe	HL64FSafe	HL64H PowerSafe	HL64P Power Safe	HL64F PowerSafe
Description	Safety roof drain Horizontal with PVC sealing flange	Safety roof drain Horizontal with PP sealing flange	Safety roof drain PowerSafe with bitumen membrane	Safety roof drain with PVC sealing flange	Safety roof drain PowerSafe with PP sealing flange
Function	Special design for connection to PVC seal strips	Special design for connection to PP-based FPO seal strips	Special design for connection to bitumen seals	Special design for connection to PVC seal strips	Special design for connection to PP-based FPO seal strips

**Any safety roof drain is available with heating, except for the PowerSafe series.
Please find further information within the particular product information.**

HL Roof Drains – Products – Data

HL62Safe Safety roof drain with 28 - 68 mm height-adjustable inlet edge
HL62.1Safe Safety roof drain like HL62Safe with additional electrical heating

Data

Drainage capacity	please see table
Material	PP, outlet unit thermally insulated
Connections	HL62Safe/7, HL62.1Safe/7: DN75 HL62Safe/1, HL62.1Safe/1: DN110 HL62Safe/2, HL62.1Safe/2: DN125 HL62Safe/5, HL62.1Safe/5: DN160
Outlet	vertical
Sealing flange	PP with stainless steel clamping ring
Inlet	Leaf catcher, height adjustable from 28 - 68 mm
Standard	ÖNORM B2501, EN 1253
Recommended for	polymer sheeting
Additional information	Notch dimension: 255 x 380 mm Tap hole dimension: Ø 255 mm HL62.1Safe: heated type with self-adjusted heat source for direct connection to a 230 V power grid (10 – 30 Watt)
Including	Lid cover, 6 pcs. HL062N.4E Hex nut alternative to wing nuts

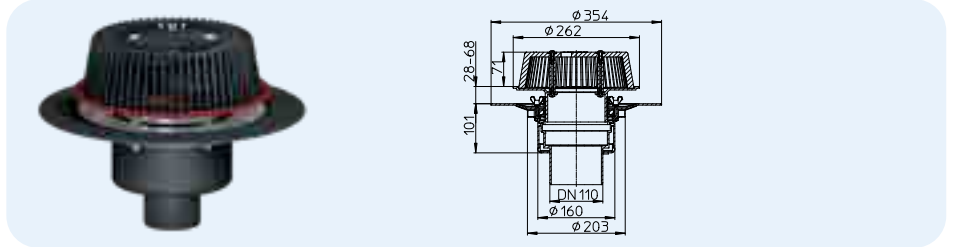

Drainage capacity according to EN 1253, with connector to a 3 m down pipe
Drainage capacity in l/s for a water level of 5 - 65 mm

nominal width	EN 1253	5 mm	15 mm	25 mm	35 mm	45 mm	55 mm	65 mm
DN75	min. 1.7 (35 mm)	0.8	3.6	5.9	8.7	12.1	14.8	15
DN110	min. 4.5 (35 mm)	0.9	3.8	6.4	9.1	12.2	15.8	20.1
DN125	min. 7.0 (45 mm)	0.9	3.8	6.2	9.1	12.1	15.7	20
DN160	min. 8.1 (45 mm)	0.9	3.8	6.5	9.3	12.8	16.5	21.5

Drainage capacity according to EN 1253 with connector freely running out
Drainage capacity in l/s for a water level of 5 - 65 mm

nominal width	EN 1253	5 mm	15 mm	25 mm	35 mm	45 mm	55 mm	65 mm
DN75	min. 1.7 (35 mm)	0.8	3.2	5.4	5.4	5.5	5.6	5.7
DN110	min. 4.5 (35 mm)	0.9	3.2	5.5	8.1	9.6	10.1	10.5
DN125	min. 7.0 (45 mm)	0.9	3.7	6	8.5	11.6	13.9	14.4
DN160	min. 8.1 (45 mm)	0.9	3.2	5.8	8.1	9.2	10.2	11

HL-Nr.	Dimension	Weight	EAN	Pcs./Package	Type
62Safe/7	DN75	3014g		1	Standard
62.1Safe/7	DN75	3154g		1	with heating
62Safe/1	DN110	3034g		1	Standard
62.1Safe/1	DN110	3174g		1	with heating
62Safe/2	DN125	3074g		1	Standard
62.1Safe/2	DN125	3214g		1	with heating
62Safe/5	DN160	3094g		1	Standard
62.1Safe/5	DN160	3234g		1	with heating

HL62HSafe Safety roof drain with bitumen membrane and 28 - 68 mm height adjustable inlet edge
HL62.1HSafe Safety roof drain like HL62HSafe with additional electrical heating

Data

Drainage capacity	please see table
Material	PP, outlet unit thermally insulated
Connections	HL62HSafe/7, HL62.1HSafe/7: DN75 HL62HSafe/1, HL62.1HSafe/1: DN110 HL62HSafe/2, HL62.1HSafe/2: DN125 HL62HSafe/5, HL62.1HSafe/5: DN160
Outlet	vertical
Sealing flange	PP, stainless steel with factory made bitumen membrane
Inlet	Leaf catcher, height adjustable from 28 - 68 mm
Standard	ÖNORM B2501, EN 1253
Recommended for	Bitumen sheeting
Additional information	Notch dimension: 255 x 380 mm Tap hole dimension : Ø 255 mm HL62.1HSafe: heated type with self-adjusted heat source for direct connection to a 230 V power grid (10 – 30 Watt)
Including	Lid cover

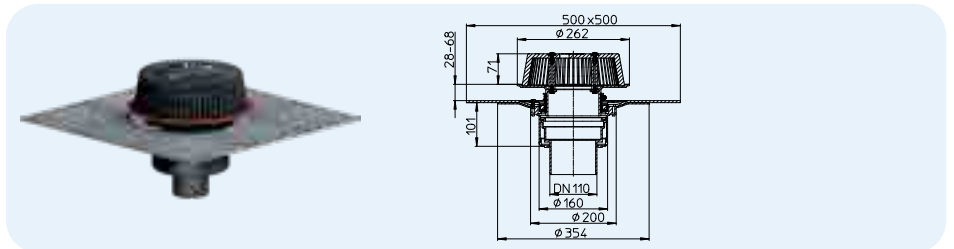

Drainage capacity according to EN 1253, with connector to a 3 m down pipe
Drainage capacity in l/s for a water level of 5 - 65 mm

nominal width	EN 1253	5 mm	15 mm	25 mm	35 mm	45 mm	55 mm	65 mm
DN75	min. 1.7 (35 mm)	0.8	3.6	5.9	8.7	12.1	14.8	15
DN110	min. 4.5 (35 mm)	0.9	3.8	6.4	9.1	12.2	15.8	20.1
DN125	min. 7.0 (45 mm)	0.9	3.8	6.2	9.1	12.1	15.7	20
DN160	min. 8.1 (45 mm)	0.9	3.8	6.5	9.3	12.8	16.5	21.5

Drainage capacity according to EN 1253 with connector freely running out
Drainage capacity in l/s for a water level of 5 - 65 mm

nominal width	EN 1253	5 mm	15 mm	25 mm	35 mm	45 mm	55 mm	65 mm
DN75	min. 1.7 (35 mm)	0.8	3.2	5.4	5.4	5.5	5.6	5.7
DN110	min. 4.5 (35 mm)	0.9	3.2	5.5	8.1	9.6	10.1	10.5
DN125	min. 7.0 (45 mm)	0.9	3.7	6	8.5	11.6	13.9	14.4
DN160	min. 8.1 (45 mm)	0.9	3.2	5.8	8.1	9.2	10.2	11

HL-Nr.	Dimension	Weight	EAN	Pcs./Package	Type
62HSafe/7	DN75	3253g		1	Standard
62.1HSafe/7	DN75	3371g		1	with heating
62HSafe/1	DN110	3494g		1	Standard
62.1HSafe/1	DN110	3611g		1	with heating
62HSafe/2	DN125	3504g		1	Standard
62.1HSafe/2	DN125	3621g		1	with heating
62HSafe/5	DN160	3514g		1	Standard
62.1HSafe/5	DN160	3631g		1	with heating

HL Roof Drains – Products – Data

HL62PSafe Safety roof drain with PVC sealing flange and 28 - 68 mm height adjustable inlet edge

HL62.1PSafe Safety roof drain like HL62PSafe with additional electrical heating

Data

Drainage capacity	please see table
Material	PP, outlet unit thermally insulated
Connections	HL62PSafe/7, HL62.1PSafe/7: DN75 HL62PSafe/1, HL62.1PSafe/1: DN110 HL62PSafe/2, HL62.1PSafe/2: DN125 HL62PSafe/5, HL62.1PSafe/5: DN160
Outlet	vertical
Sealing flange	PVC, weldable with hot air
Inlet	Leaf catcher, height adjustable from 28 - 68 mm
Standard	ÖNORM B2501, EN 1253
Recommended for	PVC sheeting
Additional information	Notch dimension: 255 x 380 mm Tap hole dimension: Ø 255 mm HL62.1PSafe: heated type with self-adjusted heat source for direct connection to a 230 V power grid (10 – 30 Watt)
Including	Lid cover

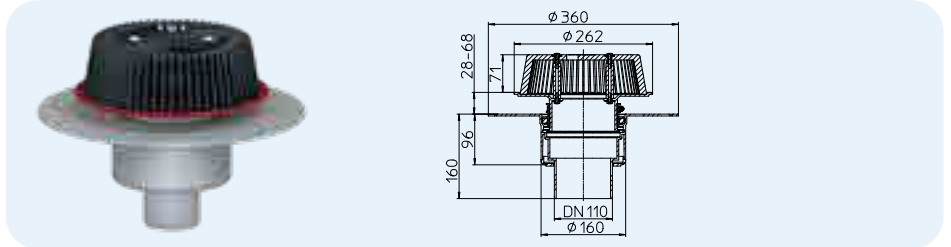

Drainage capacity according to EN 1253, with connector to a 3 m down pipe
Drainage capacity in l/s for a water level of 5 - 65 mm

nominal width	EN 1253	5 mm	15 mm	25 mm	35 mm	45 mm	55 mm	65 mm
DN75	min. 1,7 (35 mm)	0,8	3,6	5,9	8,7	12,1	14,8	15
DN110	min. 4,5 (35 mm)	0,9	3,8	6,4	9,1	12,2	15,8	20,1
DN125	min. 7,0 (45 mm)	0,9	3,8	6,2	9,1	12,1	15,7	20
DN160	min. 8,1 (45 mm)	0,9	3,8	6,5	9,3	12,8	16,5	21,5

Drainage capacity according to EN 1253 with connector freely running out
Drainage capacity in l/s for a water level of 5 - 65 mm

nominal width	EN 1253	5 mm	15 mm	25 mm	35 mm	45 mm	55 mm	65 mm
DN75	min. 1,7 (35 mm)	0,8	3,2	5,4	5,4	5,5	5,6	5,7
DN110	min. 4,5 (35 mm)	0,9	3,2	5,5	8,1	9,6	10,1	10,5
DN125	min. 7,0 (45 mm)	0,9	3,7	6	8,5	11,6	13,9	14,4
DN160	min. 8,1 (45 mm)	0,9	3,2	5,8	8,1	9,2	10,2	11

HL-Nr.	Dimension	Weight	EAN	Pcs./Package	Type
62PSafe/7	DN75	2834g		1	Standard
62.1PSafe/7	DN75	2951g		1	with heating
62PSafe/1	DN110	2874g		1	Standard
62.1PSafe/1	DN110	2991g		1	with heating
62PSafe/2	DN125	2814g		1	Standard
62.1PSafe/2	DN125	2931g		1	with heating
62PSafe/5	DN160	2894g		1	Standard
62.1PSafe/5	DN160	3011g		1	with heating

HL62FSafe Safety roof drain with PP sealing flange and 28 - 68 mm height adjustable inlet edge

HL62.1FSafe Safety roof drain like HL62FSafe with additional electrical heating

Data

Drainage capacity	please see table
Material	PP, outlet unit thermally insulated
Connections	HL62FSafe/7, HL62.1FSafe/7: DN75 HL62FSafe/1, HL62.1FSafe/1: DN110 HL62FSafe/2, HL62.1FSafe/2: DN125
Outlet	vertical
Sealing flange	PP, weldable with hot air
Inlet	Leaf catcher, height adjustable from 28 - 68 mm
Standard	ÖNORM B2501, EN 1253
Recommended for	FPO-sheeting on a PP-Basis
Additional information	Notch dimension: 255 x 380 mm Tap hole dimension: Ø 255 mm HL62.1FSafe: heated type with self-adjusted heat source for direct connection to a 230 V power grid (10 – 30 Watt)
Including	Lid cover

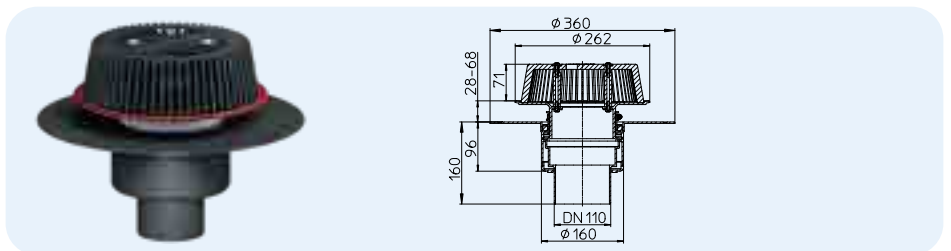

Drainage capacity according to EN 1253, with connector to a 3 m down pipe
Drainage capacity in l/s for a water level of 5 - 65 mm

nominal width	EN 1253	5 mm	15 mm	25 mm	35 mm	45 mm	55 mm	65 mm
DN75	min. 1,7 (35 mm)	0,8	3,6	5,9	8,7	12,1	14,8	15
DN110	min. 4,5 (35 mm)	0,9	3,8	6,4	9,1	12,2	15,8	20,1
DN125	min. 7,0 (45 mm)	0,9	3,8	6,2	9,1	12,1	15,7	20

Drainage capacity according to EN 1253 with connector freely running out
Drainage capacity in l/s for a water level of 5 - 65 mm

nominal width	EN 1253	5 mm	15 mm	25 mm	35 mm	45 mm	55 mm	65 mm
DN75	min. 1,7 (35 mm)	0,8	3,2	5,4	5,4	5,5	5,6	5,7
DN110	min. 4,5 (35 mm)	0,9	3,2	5,5	8,1	9,6	10,1	10,5
DN125	min. 7,0 (45 mm)	0,9	3,7	6	8,5	11,6	13,9	14,4

HL-Nr.	Dimension	Weight	EAN	Pcs./Package	Type
62FSafe/7	DN75	2974g		1	Standard
62.1FSafe/7	DN75	3091g		1	with heating
62FSafe/1	DN110	3274g		1	Standard
62.1FSafe/1	DN110	3391g		1	with heating
62FSafe/2	DN125	3514g		1	Standard
62.1FSafe/2	DN125	3634g		1	with heating

HL Roof Drains – Products – Data

HL64Safe Safety roof drain with 28 - 68 mm height adjustable nlet edge

HL64.1Safe Safety roof drain like HL64Safe with additional electrical heating

Data

Drainage capacity	please see table
Material	PP, outlet unit thermally insulated
Connections	DN75/110
Outlet	horizontal
Sealing flange	PP with stainless steel clamping ring
Inlet	Leaf catcher, height adjustable from 28 - 68 mm
Standard	ÖNORM B2501, EN 1253
Recommended for	polymer roof sheeting
Additional information	Notch dimension: 260 x 380 mm HL64.1Safe: heated type with self-adjusted heat source for direct connection to a 230 V power grid (10 – 30 Watt)
Including	Lid cover, 6 pcs. HL062N.4E Hex nut alternative to wing nuts

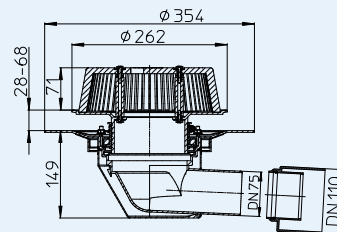

Drainage capacity according to EN 1253, with connector to a 3 m down pipe
Drainage capacity in l/s for a water level of 5 - 65 mm

nominal width	EN 1253	5 mm	15 mm	25 mm	35 mm	45 mm	55 mm	65 mm
DN75	min. 1,7 (35 mm)	0,7	3,9	6,1	8,8	11,1	15	17,5
DN110	min. 4,5 (35 mm)	0,9	3,7	6,4	8,9	12,1	15,9	20,1

Drainage capacity according to EN 1253 with connector freely running out
Drainage capacity in l/s for a water level of 5 - 65 mm

nominal width	EN 1253	5 mm	15 mm	25 mm	35 mm	45 mm	55 mm	65 mm
DN75	min. 1,7 (35 mm)	1,2	3,6	5,4	5,6	5,7	5,9	6
DN110	min. 4,5 (35 mm)	0,8	3,3	4,1	4,2	4,3	4,4	4,5

HL-Nr.	Dimension	Weight	EAN	Pcs./Package	Type
64Safe	DN75/110	2934g		1	Standard
64.1Safe	DN75/110	3054g		1	Standard with heating

HL64HSafe Safety roof drain with bitumen membrane and 28 - 68 mm height adjustable inlet edge

HL64.1HSafe Safety roof drain like HL64HSafe with additional electrical heating

Data

Drainage capacity	please see table
Material	PP, outlet unit thermally insulated
Connections	DN75/110
Outlet	horizontal
Sealing flange	PP, stainless steel with factory made bitumen membrane
Inlet	Leaf catcher, height adjustable from 28 - 68 mm
Standard	ÖNORM B2501, EN 1253
Recommended for	bitumen sheeting
Additional information	Notch dimension: 260 x 380 mm HL64.1HSafe: heated type with self-adjusted heat source for direct connection to a 230 V power grid (10 – 30 Watt)
Including	Lid cover

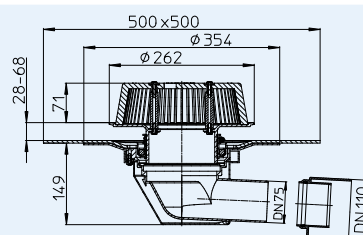

Drainage capacity according to EN 1253, with connector to a 3 m down pipe
Drainage capacity in l/s for a water level of 5 - 65 mm

nominal width	EN 1253	5 mm	15 mm	25 mm	35 mm	45 mm	55 mm	65 mm
DN75	min. 1,7 (35 mm)	0,7	3,9	6,1	8,8	11,1	15	17,5
DN110	min. 4,5 (35 mm)	0,9	3,7	6,4	8,9	12,1	15,9	20,1

Drainage capacity according to EN 1253 with connector freely running out
Drainage capacity in l/s for a water level of 5 - 65 mm

nominal width	EN 1253	5 mm	15 mm	25 mm	35 mm	45 mm	55 mm	65 mm
DN75	min. 1,7 (35 mm)	1,2	3,6	5,4	5,6	5,7	5,9	6
DN110	min. 4,5 (35 mm)	0,8	3,3	4,1	4,2	4,3	4,4	4,5

HL-Nr.	Dimension	Weight	EAN	Pcs./Package	Type
64HSafe	DN75/110	3254g		1	Standard
64.1HSafe	DN75/110	3371g		1	Standard with heating

HL Roof Drains – Products – Data

HL64PSafe Safety roof drain with PVC sealing flange and 28 - 68 mm height adjustable inlet edge

HL64.1PSafe Safety roof drain like HL64PSafe with additional electrical heating

Data

Drainage capacity	please see table
Material	PP, PVC, outlet unit thermally insulated
Connections	HL64PSafe/7, HL64.1PSafe/7: DN75 HL64PSafe/1, HL64.1PSafe/1: DN110
Outlet	horizontal
Sealing flange	PVC, weldable with hot air
Inlet	Leaf catcher, height adjustable from 28 - 68 mm
Standard	ÖNORM B2501, EN 1253
Recommended for	PVC sheeting
Additional information	260 x 380 mm HL64.1PSafe: heated type with self-adjusted heat source for direct connection to a 230 V power grid (10 – 30 Watt)
Including	Lid cover

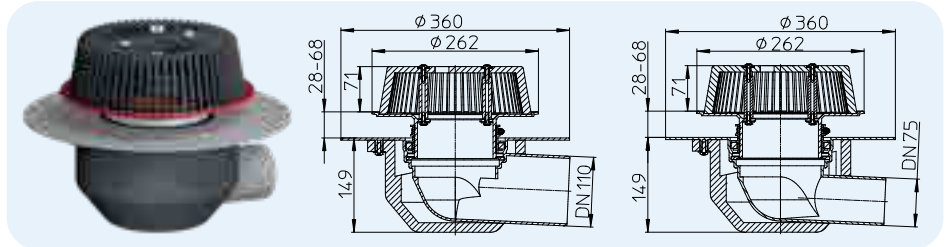

Drainage capacity according to EN 1253, with connector to a 3 m down pipe
Drainage capacity in l/s for a water level of 5 - 65 mm

nominal width	EN 1253	5 mm	15 mm	25 mm	35 mm	45 mm	55 mm	65 mm
DN75	min. 1,7 (35 mm)	0,7	3,9	6,1	8,8	11,1	15	17,5
DN110	min. 4,5 (35 mm)	0,9	3,7	6,4	8,9	12,1	15,9	20,1

Drainage capacity according to EN 1253 with connector freely running out
Drainage capacity in l/s for a water level of 5 - 65 mm

nominal width	EN 1253	5 mm	15 mm	25 mm	35 mm	45 mm	55 mm	65 mm
DN75	min. 1,7 (35 mm)	1,2	3,6	5,4	5,6	5,7	5,9	6
DN110	min. 4,5 (35 mm)	0,8	3,3	4,1	4,2	4,3	4,4	4,5

HL-Nr.	Dimension	Weight	EAN	Pcs./Package	Type
64PSafe/7	DN75	2174g		1	Standard
64.1PSafe/7	DN75	2295g		1	with heating
64PSafe/1	DN110	2231g		1	Standard
64.1PSafe/1	DN110	2348g		1	with heating

HL64FSafe Safety roof drain with PP Flange and 28 - 68 mm height adjustable inlet edge

HL64.1FSafe Safety roof drain like HL64FSafe with additional electrical heating

Data

Drainage capacity	please see table
Material	PP, outlet unit thermally insulated
Connections	HL64FSafe/7, HL64.1FSafe/7: DN75 HL64FSafe/1, HL64.1FSafe/1: DN110
Outlet	horizontal
Sealing flange	FPO-sheeting
Inlet	Leaf catcher, height adjustable from 28 - 68 mm
Standard	ÖNORM B2501, EN 1253
Recommended for	FPO-sheeting based on PP
Additional information	260 x 380 mm HL64.1FSafe: heated type with self-adjusted heat source for direct connection to a 230 V power grid (10 – 30 Watt)
Including	Lid cover

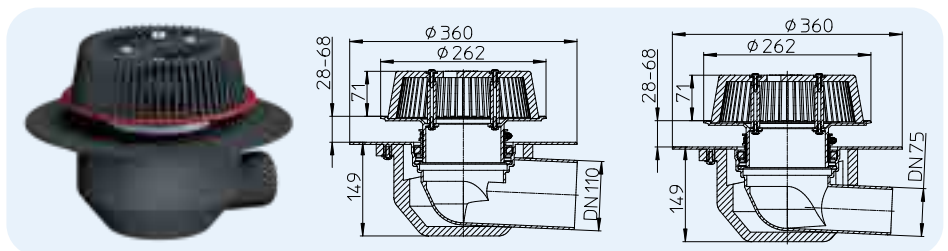

Drainage capacity according to EN 1253, with connector to a 3 m down pipe
Drainage capacity in l/s for a water level of 5 - 65 mm

nominal width	EN 1253	5 mm	15 mm	25 mm	35 mm	45 mm	55 mm	65 mm
DN75	min. 1,7 (35 mm)	0,7	3,9	6,1	8,8	11,1	15	17,5
DN110	min. 4,5 (35 mm)	0,9	3,7	6,4	8,9	12,1	15,9	20,1

Drainage capacity according to EN 1253 with connector freely running out
Drainage capacity in l/s for a water level of 5 - 65 mm

nominal width	EN 1253	5 mm	15 mm	25 mm	35 mm	45 mm	55 mm	65 mm
DN75	min. 1,7 (35 mm)	1,2	3,6	5,4	5,6	5,7	5,9	6
DN110	min. 4,5 (35 mm)	0,8	3,3	4,1	4,2	4,3	4,4	4,5

HL-Nr.	Dimension	Weight	EAN	Pcs./Package	Type
64FSafe/7	DN75	2163g		1	Standard
64.1FSafe/7	DN75	2279g		1	with heating
64FSafe/1	DN110	2273g		1	Standard
64.1FSafe/1	DN110	2388g		1	with heating

HL Roof Drains – Products – Data

- HL64H PowerSafe** Power-Safety roof drain with bitumen membrane and 28 - 58 mm height adjustable inlet edge
- HL64P PowerSafe** Power-Safety roof drain with PVC sealing flange and 28 - 58 mm height adjustable inlet edge
- HL64F PowerSafe** Power-Safety roof drain with PP- sealing flange and 28 - 58 mm height adjustable inlet edge

Data	
Drainage capacity	please see table
Material	HL64H PowerSafe: PP, Bitumen sheeting HL64P PowerSafe: PVC HL64F PowerSafe: PP
Connections	DN75
Outlet	horizontal
Sealing flange	HL64H PowerSafe: factory made bitumen membrane HL64P PowerSafe: PVC, weldable with hot air HL64F PowerSafe: PP, weldable with hot air
Inlet	Leaf catcher, height adjustable from 28 - 58 mm
Standard	ÖNORM B2501, EN 1253
Recommended for	HL64H PowerSafe: bitumen sheeting HL64P PowerSafe: PVC-sheeting HL64F PowerSafe: FPO-sheeting based on PP
Additional information	Aussparungsmaß: 220 x 380 mm
Including	Lid cover

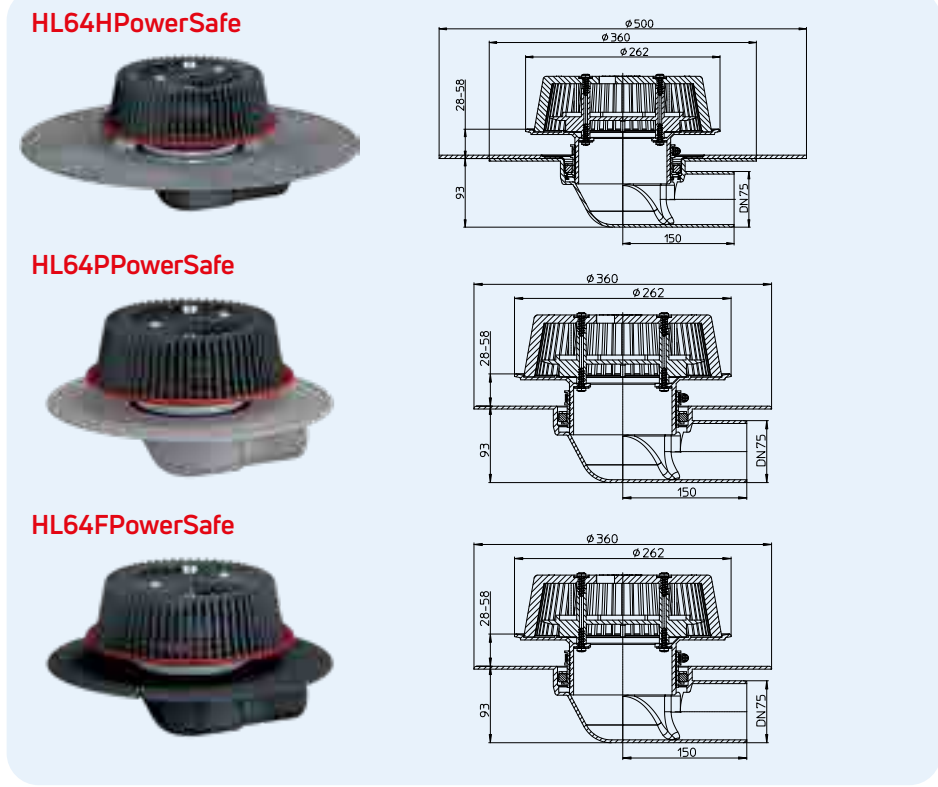

Drainage capacity according to EN 1253, with connector to a 3 m down pipe
Drainage capacity in l/s for a water level of 5 - 65 mm

nominal width	EN 1253	5 mm	15 mm	25 mm	35 mm	45 mm	55 mm	65 mm
DN75	min. 1,7 (35 mm)	0,7	3,2	7,3	12	15,6	16	16

Drainage capacity according to EN 1253, with connector to a 4,2 m down pipe
Drainage capacity in l/s for a water level of 5 - 65 mm

nominal width	EN 1253	5 mm	15 mm	25 mm	35 mm	45 mm	55 mm	65 mm
DN75	min. 1,7 (35 mm)	0,7	3,8	7,5	12,1	17,7	17,9	17,9

Drainage capacity according to EN 1253 with connector freely running out
Drainage capacity in l/s for a water level of 5 - 65 mm

nominal width	EN 1253	5 mm	15 mm	25 mm	35 mm	45 mm	55 mm	65 mm
DN75	min. 1,7 (35 mm)	1	3,8	3,9	4,1	4,2	4,3	4,5

HL-Nr.	Dimension	Weight	EAN	Pcs./Package
64H PowerSafe	DN75	4161g		1
64P PowerSafe	DN75	3284g		1
64F PowerSafe	DN75	3010g		1

HL062.1Safe Safety drain attachment

Data	
Drainage capacity	please see table
Material	PP
Inlet	Leaf catcher, height adjustable from 28 - 58 mm
Standard	ÖNORM B2501, EN 1253
Recommended for	roof drains for safety drainage

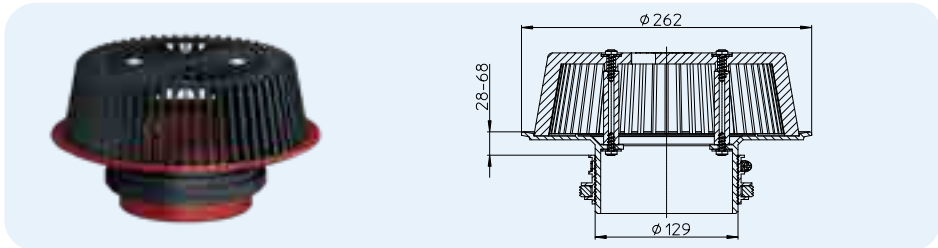

HL-Nr.	Dimension	Weight	EAN	Pcs./Package
062.1Safe		1250g		1

Ø 200

123 x 123



SIPHONS ABLÄUFE

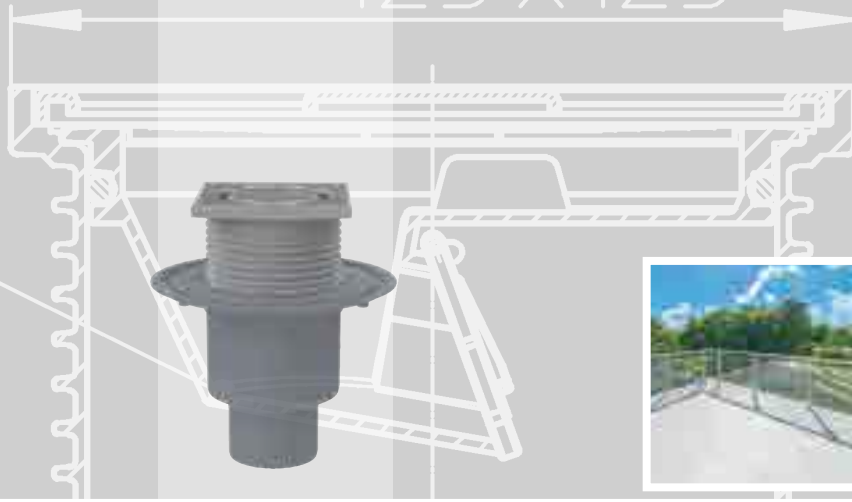

12-70

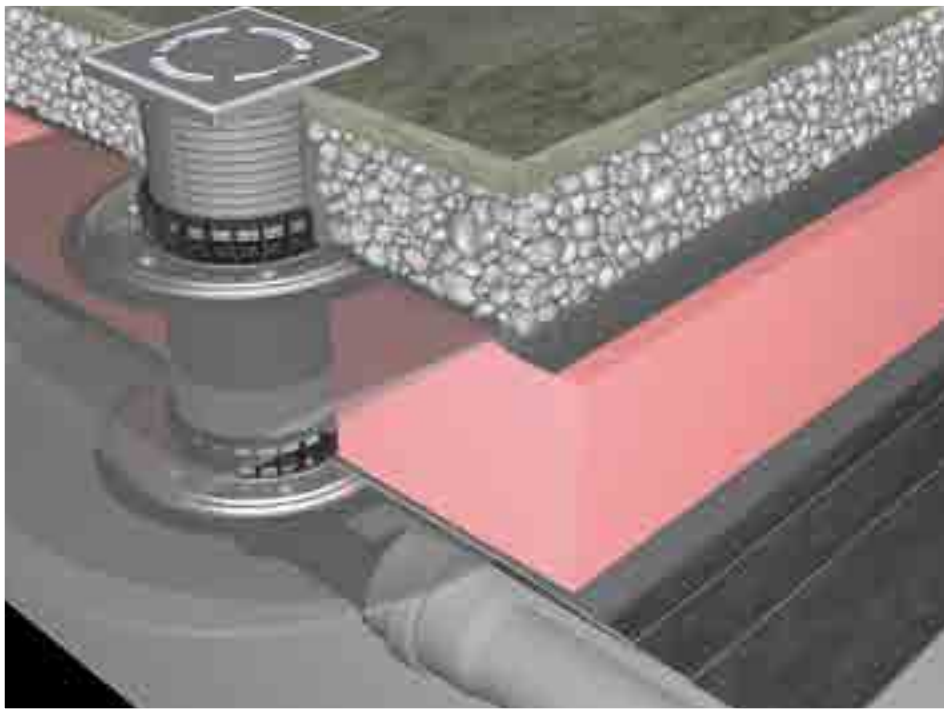

144



HL Drains

12. Balcony and terrace

12

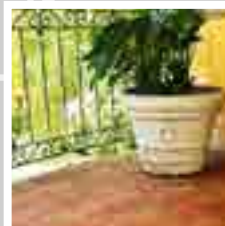

HL Balcony and terrace drains

Basic information about design and installation

In general the draining of rain water on terrace and balcony surfaces should happen with gullies. Already during planning some important topics should be taken into consideration:

▲ To choose the right drain including all accessories a detailed plan of the floor construction (ceiling material, thermal insulation, waterproofing...) has to be defined. Especially with inverted roof constructions different drain positions both above the thermal insulation and on the waterproofing has to be provided.

▲ The area (or subarea) and the rainfall rate has to be known, when choosing the fitting gully. Therefore important is the calculated rainwater rate (l/s) and the capacity of the gully (l/s).

▲ To avoid leakage in the structure, it is important, to take care of the kind of waterproofing, especially the connection between drain and the local waterproofing. Please check the compatibility between the local waterproofing on the terrace and our HL prefabricated sealing kits.

▲ Please notice, that acc. international standards at terraces and loggias, which are surrounded by attic walls, one should care for a suitable emergency drainage. The sense of it is, to avoid overload on the terrace construction by backwater, caused by a blocked drain or by heavy rain events. Therefore we recommend to clean gullies frequently.

▲ According to ÖNORM roof drains should only be connected to rain water sewage. Should this not be possible, we recommend, to use gullies with integrated frost-proof flap.

▲ Maintenance

In accordance with DIN 1986-3, roof drains, balcony and terrace drains, as well as emergency drains should be inspected and, if necessary, serviced at least every 6 months. Especially in the autumn months or after extreme weather events, the maintenance should be carried out at shorter intervals. Care should be taken to remove leaves and dirt from the inlet grates or leaf catchers to ensure that rainwater can flow in and out unhindered. Missing and defective parts shall be replaced as part of this work. The HL635N drainage and inspection chamber facilitates this necessary work, especially on green roofs, and at the same time ensures safe drainage with its generous drainage openings

Relevant standards/directives

ÖNORM B2501	Drainage of buildings
DIN 1986-100	Drainage systems for buildings and estates
ÖNORM EN 12056	Gravity drainage systems inside of buildings
EN 1253	Drains for buildings
ÖNORM B2209	Waterproofing works
ÖNORM B2220	Roof waterproofings with bitumen and plastic sheetings
ÖNORM B7209	Waterproofings for buildings
ÖNORM B7220	Roofs with waterproofings

Selection of the convenient drain

Selective criteria	Requirements	Product
Drainage surface	<p>When you calculate the quantity of occurring rain water acc. ÖNORM B2501 and DIN 1986-100, you have to use at least the standard rain yield factor of 300 l/ (s x ha).</p> <p>Quantity of rain water = 0,03 l/s x Drainage surface (m²)</p> <p>Quantity of gullies = $\frac{\text{Absolute quantity of rain water}}{\text{Capacity of the gully}}$</p>	For the exact definition of the right drain and the quantity of gullies, please mind the capacity of the particular article.
Ceiling construction	To find out, what is the best composition of the drain, like extension (with or without flange), gravel guard, sealing kit or heating, a detailed plan of the different layers of the ceiling is necessary.	Extension (with or without flange) Sealing kit Gravel guard eventually heating
Waterproofing	<p>To have a save and leak-proof connection between drain and local waterproofing, the waterproofing material on the ceiling should be known.</p> <p>Local waterproofing (2 mm thick, flexible)</p> <p>Bitumen coating</p> <p>Bitumen waterproofing, liquid bitumen compound</p> <p>PVC waterproofing</p> <p>FPO waterproofing, based on PP</p> <p>Liquid sealing compounds</p>	HL83.0, HL8300.0 HL83 (with EPDM-foil) HL83.H, HL8300H (with bitumen flange) Drain HL80H, HL3100TH, HL5100TH Extensions HL85NH, HL8500H HL83.P, HL8300.P HL83.PP, HL8300.PP (with PP flange) HL83.M, HL8300.M (with textile coated membrane)
Direction of the outlet	horizontal vertical	HL80-series, HL90, HL90.2, HL5100T-series HL80-series, HL310N.2, HL3100T-series
Sewer	Rain water sewer Mixed sewer	All types of drains applicable Gullies with frost-proof flap: HL310N.2, HL3100T-series, HL5100T-series

Additional information

Acc. DIN 1986-100 it has to be checked at all roof constructions, if emergency overflows are necessary, considering the expected incidents of rain at the construction site, the construction itself, the hydro-insulation, the statics of the roof and the special character of the drainage system.

HL Balcony and terrace drains – Sectional drawings

Terrace, slabs in gravel laid, without thermal insulation

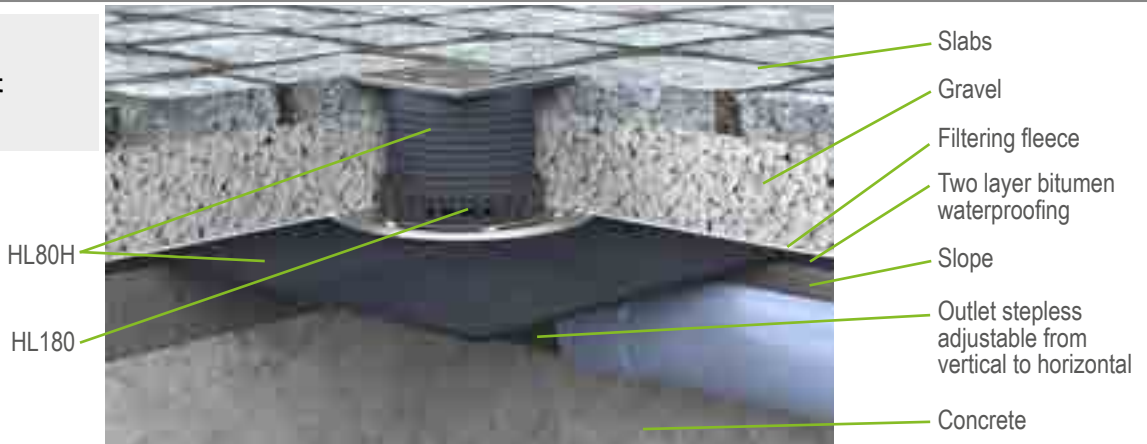

Terrace, slabs laid in gravel, thermal insulation, Inverted construction

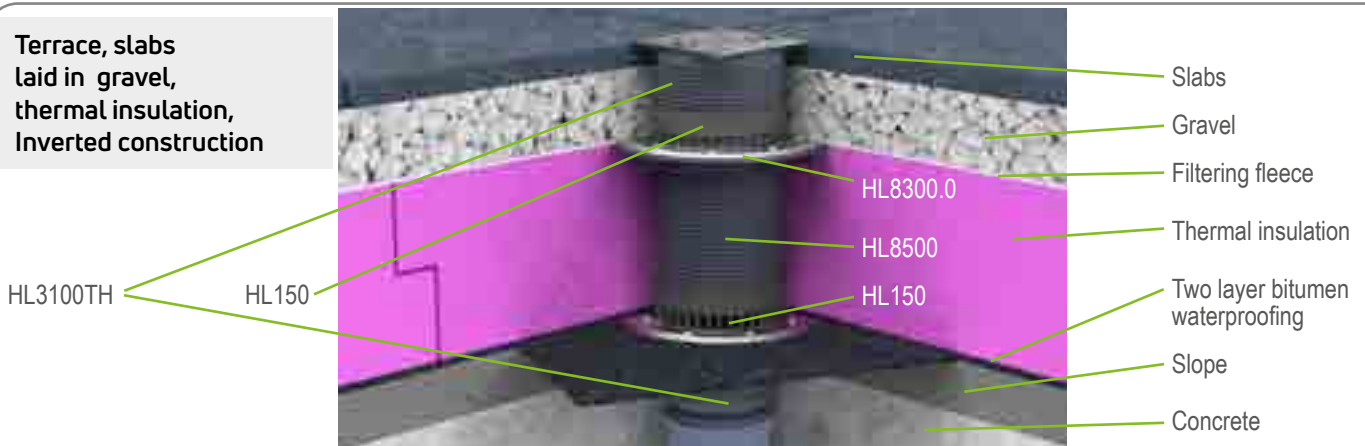

Terrace, floor laid on spacer with vapor barrier and thermal insulation

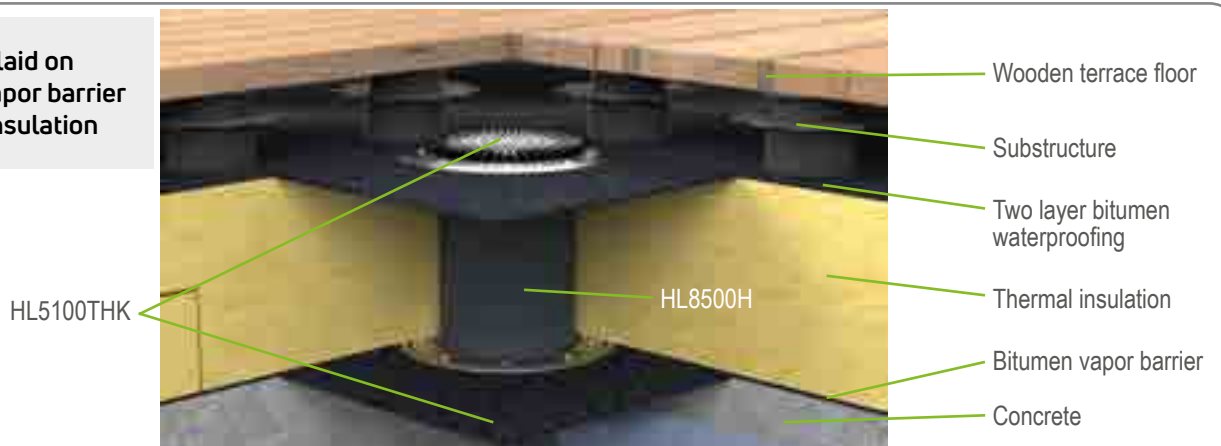

Terrace tiled with integration into the composite waterproofing

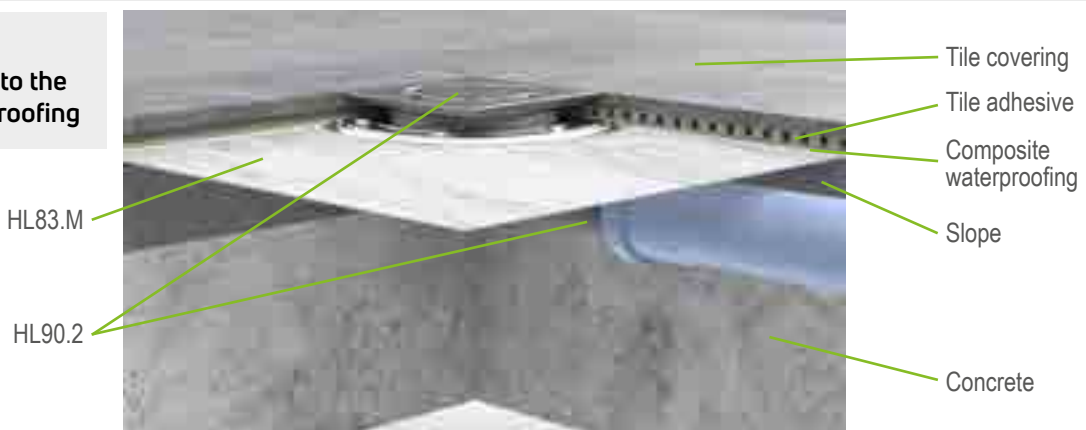

HL Balcony and terrace drains – Installation

Terrace, slab fit into gravel bed, thermal insulation, inverted construction



1. Set gully including lot cover into the tap hole



2. Weld the prefabricated bitumene flange with the local bitumene waterproofing



3. Set the fleece, put on the gravel guard (HL180), apply the thermal insulation



4. Shorten extension with flange (HL85N) and adjust to the height of the thermal insulation, set on the gravel guard (HL180), set the lot cover



5. Clamp fleece between the stainless steel clamp ring (HL83.0) and the extension (HL85N), set the gravel guard (HL180), adjust the extension to the final slab height



6. Coat the gravel guard and the extension with fleece, fill in gravel embankment and lay the slabs, insert grate

HL Balcony and terrace drains – Products – Overview

Drains

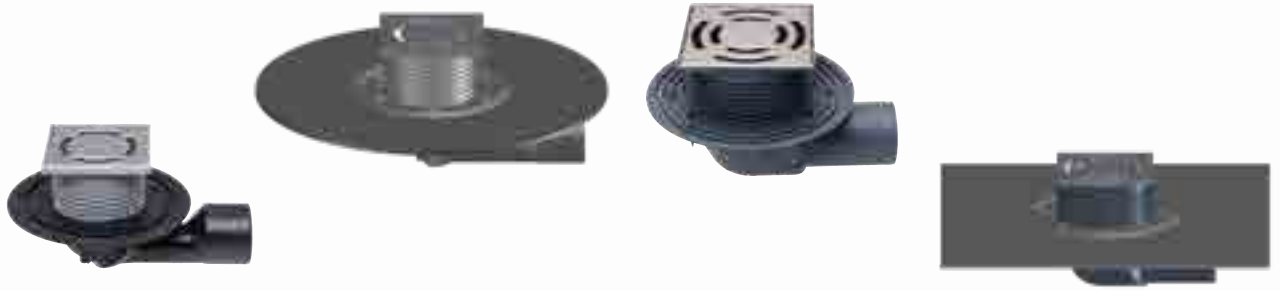

Product	HL80	HL80H	HL5100T	HL5100TH
Description	Standard drain	Standard drain with bitumen flange	Drain horizontal with high capacity	Drain horizontal with high capacity and bitumen flange
Function	Usage horizontal and vertical	Usage horizontal and vertical, especially for bitumen waterproofing	For surfaces up to 51 m ²	For surfaces up to 51 m ² , for bitumen waterproofings

Extensions



Product	HL340N	HL3400	HL3400	HL85N	HL85N	HL8500
Description	Standard extension	Extension	Extension	Extension with flange	Extension with flange	Extension with flange
Function	To elongate the extension	To elongate the extension, fits to drain series HL3100 and 5100	To elongate the extension, fits to drain series HL3100 and 5100	Adjustment of the drain to the waterproofing level	Adjustment of the drain to the waterproofing level	Adjustment of the drain to the waterproofing level. Fits to series HL3100 and HL5100

Sealing kits



Product	HL83	HL8300	HL83.0	HL8300.0	HL83.M	HL8300.M
Description	Sealing kit with EPDM-foil	Sealing kit with EPDM-foil	Sealing kit without foil	Sealing kit without foil	Sealing kit with textile coated membrane	Sealing kit with textile coated membrane
Function	For bitumen coatings	For bitumen coatings, fits to drain series HL3100 and 5100	Clamping of local waterproofings	For clamping of local waterproofings, fits to drain series HL3100 and HL5100	For liquid sealing compounds	For liquid sealing compounds, fits to drains HL3100-series and HL5100-series

Accessories



Product	HL180	HL150	HL080.8E	HL157	HL82
Description	Gravel guard	Drainage element	Leaf catcher	Leaf catcher	Heating kit
Function	For the drainage of rain water on the waterproofing level, e.g. inverted construction	For the drainage of rain water on the waterproofing level, e.g. inverted roofs. For drains HL3100T-series and HL5100T-series.	For not walkable surfaces like gravel embankment, green surfaces	For not walkable surfaces like gravel embankment, green surfaces, fits to the drain series HL3100T and HL5100T	To heat the gully and to avoid ice

HL Balcony and terrace drains – Products – Overview



HL90.2

Drain horizontal

Extremely flat, for flat floor constructions

HL310N.2

Drain vertical

At tap holes, high capacity

HL3100T

Drain vertical, high capacity

For surfaces up to 55 m²

HL3100TH

Drain vertical, high capacity and bitumen flange

For surfaces up to 55 m², especially for bitumen waterproofings



Product data see chapter Sealing kits/Extensions

HL8500H

Extension with bitumen flange

Adjustment of the drain to the bitumen waterproofing

HL8500HL85NH

Extension with bitumen flange

Adjustment of the drain to the bitumen waterproofing level. Fits to series HL3100 and HL5100

HL85NC

Extension with polymere concrete flange

Adjustment of the drain to the liquid sealing compound

HL8500H

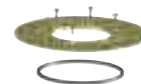
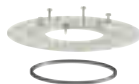

Product data see chapter Sealing kits/Extensions

HL83.H

Sealing kit with bitumen flange

For bitumen waterpr. and liquid bitumen compounds

HL8300.H

Sealing kit with bitumen flange

For bitumen waterproofings and liquid bitumen compounds. Fits to drains HL3100-series and HL5100-series

HL83.P

Sealing kit with PVC-flange

For PVC-waterproofings

HL8300.P

Sealing kit with PVC-flange

For PVC-waterproofings. For drains HL3100-series and HL5100-series

HL83.PP

Sealing kit with PP-flange

For FPO-waterpr., based on PP

HL8300.PP

Sealing kit with PP-flange

For FPO waterproofings, based on PP. For drains HL3100-series and HL5100-series



HL181

Gravel trap

For slaps, fit into gravel embankment

HL151

Gravel guard

Below slaps or wooden panels. For drains HL3100T-series and HL5100T-series

HL152

Thermal insulation - horizontal

For upgrading HL5100T to an insulated version

HL153

Thermal insulation - vertical

For upgrading HL3100T to an insulated version

HL155

Thermal insulation kit incl. heating, horizontal

Upgrade kit, thermal insulated and with 18W/230V heating for HL5100T(H)

HL156

Thermal insulation kit incl. heating, vertical

Upgrade kit, thermal insulated and with 18W/230V heating for HL3100T(H)

HL Balcony and terrace drains - Products - Data

HL80 Balcony and terrace drain with convertable outlet

Data	
Material	PP, PE
Outlet	DN50/75 cuttable, convertable from horizontal to vertical, Material PE, pluggable and weldable
Extension	123 x 123 mm, cuttable
Inlet	Stainless steel grate 115 x 115 mm
Stench trap	Frost-proof flap
Standard	EN 1253
Load classification	K3 – max. 300 kg
Additional information	For surfaces up to 25 m ² Recess dimensions: 185 x 340 mm, Tap hole diameter: 185mm
Including	Supporting frame, lot cover

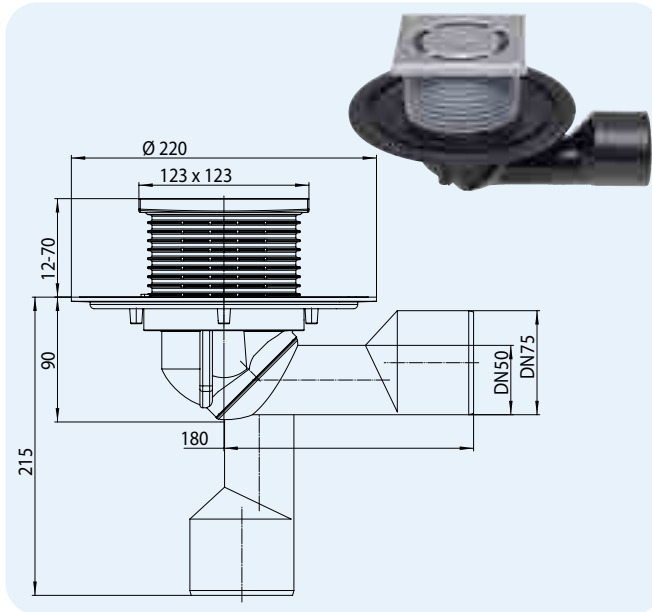

HL-No.	Dimension	Weight	EAN	Piece/package
80	DN50/75	650 g	+700806	1

HL80H Balcony and terrace drain with bitumen flange

Data	
Material	PP, PE, pre-welded bitumen membrane
Outlet	DN50/75 cuttable, convertable from horizontal to vertical, Material PE, pluggable and weldable
Extension	123 x 123 mm, cuttable
Stench trap	Frost-proof flap
Inlet	Stainless steel grate 115 x 115 mm
Standard	EN 1253
Load classification	K3 – max. 300 kg
Recommended for	Bitumen waterproofings
Additional information	For surfaces up to 25 m ² Recess dimensions: 185 x 340 mm, Tap hole diameter: 185mm
Including	Supporting frame, Lid cover

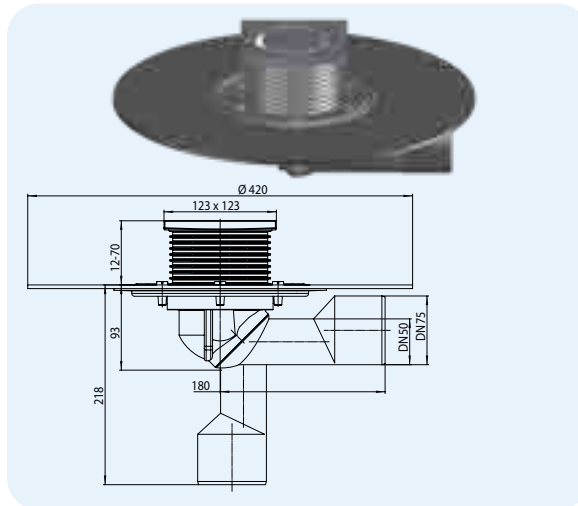

HL-No.	Dimension	Weight	EAN	Piece/package
80H	DN50/75	1300 g	+701803	1

Drainage table HL80, HL80H

Tested according to EN 1253-2:2015 according to pt. 5.5.2.1 Fig. 10a) + 10b) and pt. 5.5.1.2 Fig. 9
Drainage capacity tested according to EN 1253-2:2015 according to pt. 5.5.2.1 on downpipe 3 m

Nominal width	EN 1253	5 mm	15 mm	25 mm	35 mm	45 mm	55 mm	65 mm	75 mm
DN 50	min. 0,9 (35 mm)	0,30	0,90	0,95	1,05	1,10	1,20	1,25	1,30
DN 75	min. 1,7 (35 mm)	0,35	1,00	1,10	1,30	1,35	1,40	1,45	1,50

Drainage capacity measured according to EN 1253-2:2015 according to clause 5.5.1.2 free draining

Nominal width	EN 1253	5 mm	15 mm	20 mm	35 mm	45 mm	55 mm	65 mm	75 mm
DN 50	min. 0,8 (20 mm)	0,30	0,90	1,00	1,20	1,25	1,30	1,35	1,40
DN 75	min. 0,8 (20 mm)	0,30	0,90	0,95	1,10	1,20	1,30	1,35	1,40

HL81G Balcony and terrace drain with convertable outlet, cast iron frame and grate

Data

Material	PP, PE, cast iron/PP
Outlet	DN50/75 cuttable, convertable from horizontal to vertical, Material PE, pluggable and weldable
Frame	Cast iron 150 x 150 mm
Extension	Plastic, cuttable
Inlet	Cast iron grate 137 x 137 mm
Stench trap	Frost-proof flap
Standard	EN 1253
Load classification	A – max. 1,5 t
Recommended for	Loads up to 1,5 t
Additional information	For surfaces up to 25 m ² Recess dimensions: 185 x 340 mm, Tap hole diameter: 185mm
Including	Lid cover

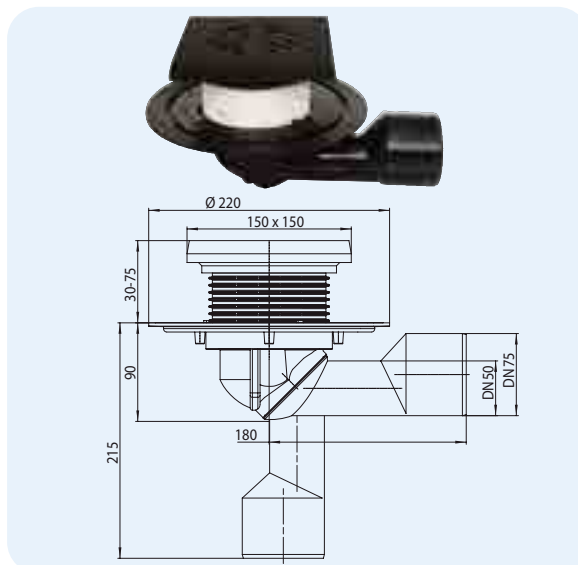
HL39G

HL037G.1E



HL037G.2E



HL01067D



HL080.4E

HL80K

HL0300.0EN

HL-No.	Dimension	Weight	EAN	Piece/package
81G	50/75	2620 g	+000876	1
81GH	50/75	3114 g	+600337	1

Drainage table HL81G, HL81GH

Tested according to EN 1253-2:2015 according to pt. 5.5.2.1 Fig. 10(a) + 10(b) and pt. 5.5.1.2 Fig. 9

Drainage capacity tested according to EN 1253-2:2015 according to pt. 5.5.2.1 on downpipe 3 m

Nominal width	EN 1253	5 mm	15 mm	25 mm	35 mm	45 mm	55 mm	65 mm	75 mm
DN 50	min. 0,9 (35 mm)	0,30	0,95	1,00	1,10	1,25	1,30	1,35	1,40
DN 75	min. 1,7 (35 mm)	0,30	0,95	1,30	1,35	1,40	1,45	1,55	1,60

Drainage capacity measured according to EN 1253-2:2015 according to clause 5.5.1.2 free draining

Nominal width	EN 1253	5 mm	15 mm	20 mm	35 mm	45 mm	55 mm	65 mm	75 mm
DN 50	min. 0,8 (20 mm)	0,35	1,05	1,25	1,35	1,40	1,45	1,50	1,55
DN 75	min. 0,8 (20 mm)	0,35	1,05	1,15	1,25	1,30	1,35	1,40	1,45

HL90 Balcony and terrace drain, extra-flat, installation height 57 mm

Data

Material	PP
Outlet	DN40/50 cuttable, horizontal, pluggable
Extension	123 x 123 mm, cuttable
Inlet	Stainless steel grate 115 x 115 mm
Standard	EN 1253
Load classification	K3 – max. 300 kg
Additional information	Installation height 57 mm; For surfaces up to 18 m ² , Recess dimensions: 185 x 340 mm, frost-proof
Including	Supporting frame, Lot cover, Sand trap

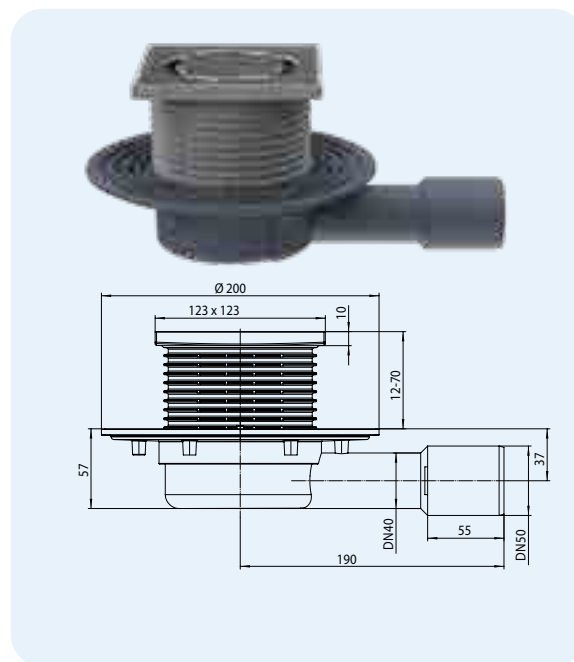

HL090.0E

HL37N

HL037Pr.1E



HL037N.0E



HL037N.2E



HL01067D

HL90K

HL0300.0EN

Drainage table HL90

Tested according to EN 1253-2:2015 according to pt. 5.5.2.1 Fig. 10(a) + 10(b) and pt. 5.5.1.2 Fig. 9

Drainage capacity tested according to EN 1253-2:2015 according to pt. 5.5.2.1 on downpipe 3 m

Nominal width	EN 1253	5 mm	15 mm	25 mm	35 mm	45 mm	55 mm	65 mm	75 mm
DN 40	-	-	-	-	-	-	-	-	-
DN 50	min. 0,9 (35 mm)	0,30	0,80	0,85	0,90	0,95	1,00	1,05	1,10

Abflaufleistung gemessen nach EN 1253-2:2015 nach Pkt. 5.5.1.2 frei auslaufend

Nominal width	EN 1253	5 mm	15 mm	20 mm	35 mm	45 mm	55 mm	65 mm	75 mm
DN 40	min. 0,6 (20 mm)	0,30	0,65	0,75	0,80	0,85	0,90	0,95	1,00
DN 50	min. 0,8 (20 mm)	0,30	0,70	0,75	0,90	0,95	1,00	1,10	1,15

HL-No.	Dimension	Weight	EAN	Piece/package
90	DN40/50	425 g	+006359	1

HL90.2 Balcony and terrace drain like HL90, but with frost-proof stench trap

Data

Material	PP
Outlet	DN40/50 cuttable, horizontal, pluggable
Extension	123 x 123 mm, cuttable
Inlet	Stainless steel grate 115 x 115 mm
Stench trap	Frost-proof flap
Standard	EN 1253
Load classification	K3 – max. 300 kg
Additional information	Installation height 57 mm; For surfaces up to 18 m ² , Recess dimensions: 185 x 340 mm, frost-proof
Including	Supporting frame, Lot cover

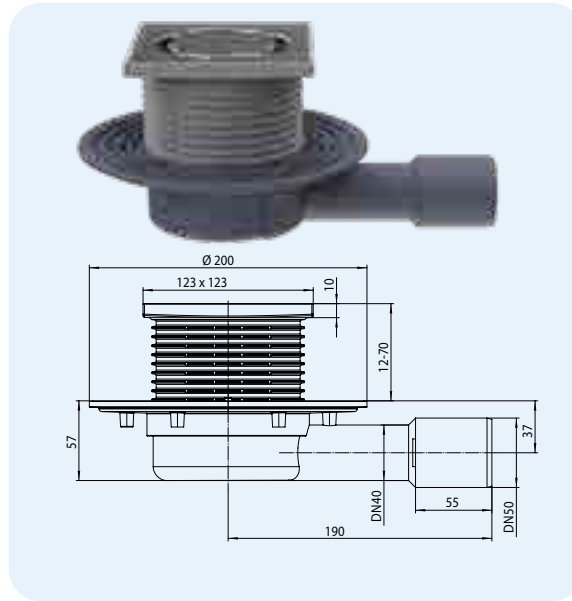

Drainage table HL90.2

Tested according to EN 1253-2:2015 according to pt. 5.5.2.1 Fig. 10(a) + 10(b) and pt. 5.5.1.2 Fig. 9
Drainage capacity tested according to EN 1253-2:2015 according to pt. 5.5.2.1 on downpipe 3 m

Nominal width	EN 1253	5 mm	15 mm	25 mm	35 mm	45 mm	55 mm	65 mm	75 mm
DN 40	-	-	-	-	-	-	-	-	-
DN 50	min. 0,9 (35 mm)	0,35	0,75	0,8	0,85	0,9	0,95	1,00	1,05

Drainage capacity measured according to EN 1253-2:2015 according to clause 5.5.1.2 free draining

Nominal width	EN 1253	5 mm	15 mm	20 mm	35 mm	45 mm	55 mm	65 mm	75 mm
DN 40	min. 0,6 (20 mm)	0,35	0,70	0,75	0,80	0,85	0,90	0,95	1,00
DN 50	min. 0,8 (20 mm)	0,40	0,75	0,80	0,90	0,95	1,00	1,05	1,10

HL-No. 90.2	Dimension DN40/50	Weight 425 g	EAN +016853	Piece/package 1
----------------	----------------------	-----------------	----------------	--------------------

HL90KH Drain body with bitumen flange, installation height 61 mm

Data

Material	PP, pre-welded bitumen flange
Outlet	DN40/50 cuttable, horizontal, pluggable
Cover	Flat leaf catcher HL181
Standard	EN 1253
Additional information	Installation height 61 mm; for surfaces up to 17 m ² (calculated with 400 lit of rainfall (s x ha), frost resistant, recess dimensions: 185 x 340 mm

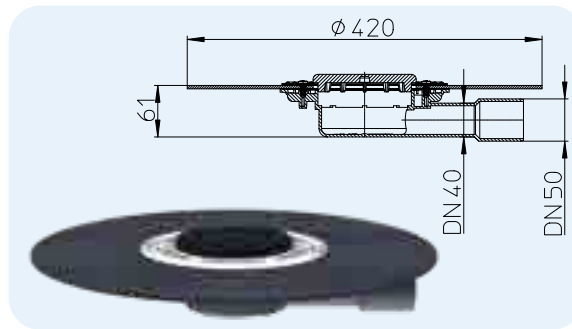

HL-No. 90KH	Dimension DN40/50	Weight 1100 g	EAN +036998	Piece/package 1
----------------	----------------------	------------------	----------------	--------------------

Drainage table HL90KH

Tested according to EN 1253-2:2015 according to pt. 5.5.2.1 Fig. 10(a) + 10(b) and pt. 5.5.1.2 Fig. 9
Drainage capacity tested according to EN 1253-2:2015 according to pt. 5.5.2.1 on downpipe 3 m

Nominal width	EN 1253	5 mm	15 mm	25 mm	35 mm	45 mm	55 mm	65 mm	75 mm
DN 40	-	-	-	-	-	-	-	-	-
DN 50	min. 0,9 (35 mm)	0,35	0,85	0,9	0,95	1	1,1	1,15	1,2

Drainage capacity measured according to EN 1253-2:2015 according to clause 5.5.1.2 free draining

Nominal width	EN 1253	5 mm	15 mm	20 mm	35 mm	45 mm	55 mm	65 mm	75 mm
DN 40	min. 0,6 (20 mm)	0,50	0,65	0,70	0,80	0,85	0,90	0,95	1,00
DN 50	min. 0,8 (20 mm)	0,30	0,65	0,70	0,80	0,85	0,90	0,95	1,00

HL310N.2 Balcony and terrace drain with frost-proof flap, DN50/75/110

Data

Material	PP
Outlet	DN40/50 cuttable, vertical, pluggable
Extension	123 x 123 mm, cuttable
Inlet	Stainless steel grate 115 x 115 mm
Stench trap	Frost-proof flap
Standard	EN 1253
Load classification	K3 – max. 300 kg
Additional information	For surfaces up to 21 m ² , Recess dimensions: min. 185 x 185 mm, Tap hole diameter: 180 mm, frost-proof
Including	Supporting frame, Lot cover

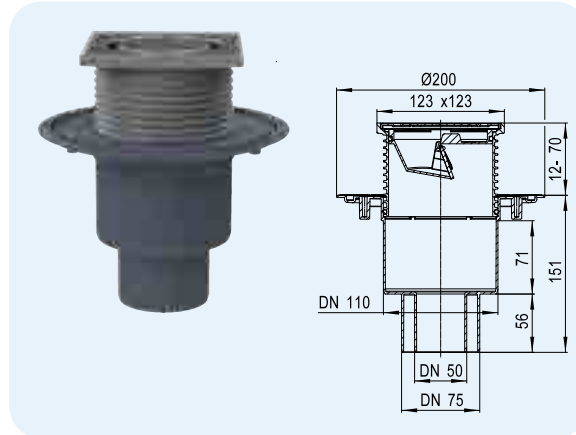

HL-No. 310N.2	Dimension DN50/75/110	Weight 565 g	EAN +021963	Piece/package 1
------------------	--------------------------	-----------------	----------------	--------------------

Drainage table HL310N.2

Tested according to EN 1253-2:2015 according to pt. 5.5.2.1 Fig. 10(a) + 10(b) and pt. 5.5.1.2 Fig. 9

Drainage capacity tested according to EN 1253-2:2015 according to pt. 5.5.2.1 on downpipe 3 m

Drainage capacity measured according to EN 1253-2:2015 according to clause 5.5.1.2 free draining

Nominal width	EN 1253	5 mm	15mm	25mm	35mm	45mm	55mm	65mm	75mm	Nominal width	EN 1253	5 mm	15mm	20mm	35mm	45mm	55mm	65mm	75mm
DN 50	min. 0,9 (35 mm)	0,30	0,85	1,15	1,20	1,20	1,25	-	-	DN 50	min. 0,8 (20 mm)	0,25	0,80	0,85	0,90	0,95	1,00	1,05	-
DN 75	min. 1,7 (35 mm)	0,30	0,80	0,90	0,95	1,00	1,05	1,1	-	DN 75	min. 0,8 (20 mm)	0,25	0,80	0,85	0,90	0,95	1,00	1,05	-
DN 110	min. 4,5 (35 mm)	0,35	0,8	0,85	0,90	0,95	1,00	1,05	-	DN 110	min. 1,4 (20 mm)	0,25	0,80	0,85	0,90	0,95	1,00	1,05	-

HL310KH Drain body with bitumen flange

Data

Material	PP, pre-welded bitumen flange
Outlet	DN40/50 cuttable, vertical, pluggable
Cover	Flat leaf catcher HL181
Standard	EN 1253
Additional information	for surfaces up to 32 m ² (calculated with 400 lit of rainfall (s x ha), frost resistant, recess dimensions: 185 x 185 mm Core drilling 185mm

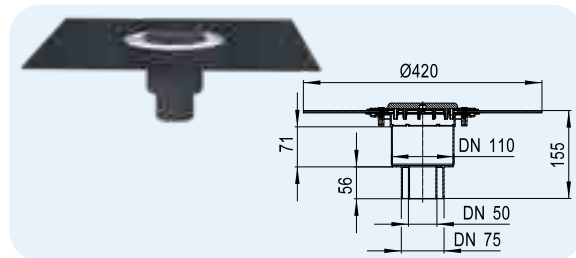

HL-No. 310KH	Dimension DN50/75/110	Weight 1050 g	EAN +037018	Piece/package 1
-----------------	--------------------------	------------------	----------------	--------------------

Drainage table HL310KH

Tested according to EN 1253-2:2015 according to pt. 5.5.2.1 Fig. 10(a) + 10(b) and pt. 5.5.1.2 Fig. 9

Drainage capacity tested according to EN 1253-2:2015 according to pt. 5.5.2.1 on downpipe 3 m

Drainage capacity measured according to EN 1253-2:2015 according to clause 5.5.1.2 free draining

Nominal width	EN 1253	5 mm	15mm	25mm	35mm	45mm	55mm	65mm	75mm	Nominal width	EN 1253	5 mm	15mm	20mm	35mm	45mm	55mm	65mm	75mm
DN 50	min. 0,9 (35 mm)	0,35	1,50	3,15	5,40	-	-	-	-	DN 50	min. 0,8 (20 mm)	0,50	1,60	1,70	1,80	1,85	1,90	1,95	-
DN 75	min. 1,7 (35 mm)	0,30	1,30	1,50	1,55	1,60	1,65	1,70	1,80	DN 75	min. 0,8 (20 mm)	0,40	1,25	1,30	1,40	1,45	1,50	1,55	1,60
DN 110	min. 4,5 (35 mm)	0,30	1,25	1,35	1,40	1,50	1,55	1,60	1,65	DN 110	min. 1,4 (20 mm)	0,35	1,20	1,30	1,40	1,45	1,50	1,55	1,60

HL5100T Balcony and terrace drain, horizontal, with frost-proof flap; high capacity

Data

Material	PP
Outlet	DN75, horizontal, pluggable
Frame	145 x 145mm, stainless steel, cuttable in height
Grate	Stainless steel 138 x 138
Stench trap	Frost-proof flap
Standard	EN 1253
Load classification	K 3 - max. 300 kg
Additional information	For surfaces up to 51 m ² ; Recess dimensions: min. 220 x 340 mm
Including	Supporting frame, lid cover

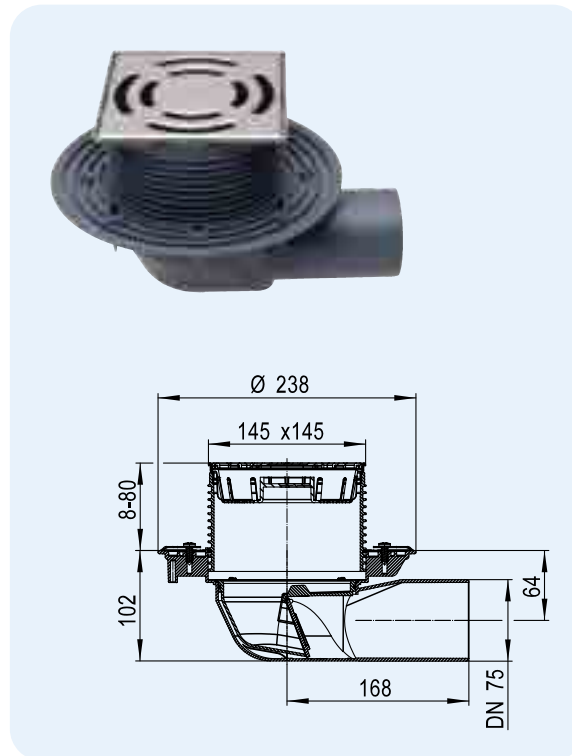

HL-No. 5100T	Dimension DN75	Weight 904 g	EAN +034703	Piece/package 1
-----------------	-------------------	-----------------	----------------	--------------------

HL5100TH Balcony and terrace drain like HL5100T, but with bitumen flange

Data

Material	PP, pre-welded bitumen flange
Outlet	DN75, horizontal, pluggable
Frame	145 x 145mm, stainless steel, cuttable in height
Grate	Stainless steel 138 x 138
Stench trap	Frost-proof flap
Standard	EN 1253
Load classification	K 3 - max. 300 kg
Additional information	For bitumen surfaces up to 51 m ² ; Recess dimensions: min. 220 x 340 mm
Including	Supporting frame, lid cover

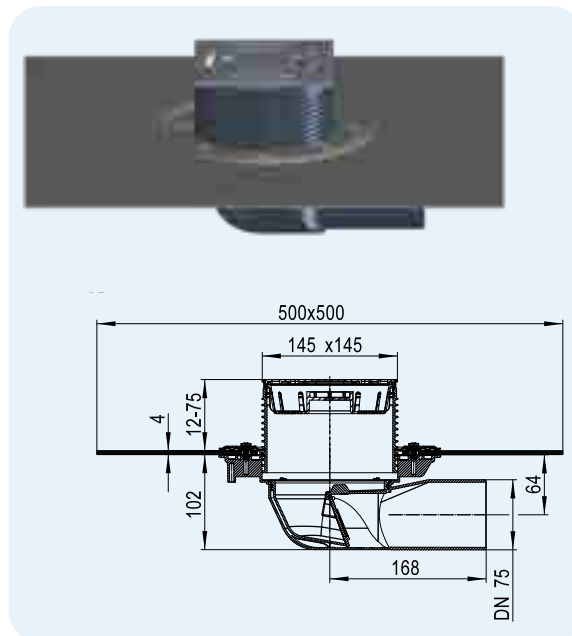

HL-No. 5100TH	Dimension DN75	Weight 2266 g	EAN +034710	Piece/package 1
------------------	-------------------	------------------	----------------	--------------------

Drainage table HL5100T, HL5100TH

Tested according to EN 1253-2:2015 according to pt. 5.5.2.1 Fig. 10a) + 10b) and pt. 5.5.1.2 Fig. 9
Drainage capacity tested according to EN 1253-2:2015 according to pt. 5.5.2.1 on downpipe 3 m

Nominal width	EN 1253	5 mm	15 mm	25 mm	35 mm	45 mm	55 mm	65 mm	75 mm
DN 75	min. 1,7 (35 mm)	0,45	1,50	2,85	2,90	2,95	3,40	4,40	4,45

Drainage capacity measured according to EN 1253-2:2015 according to clause 5.5.1.2 free draining

Nominal width	EN 1253	5 mm	15 mm	20 mm	35 mm	45 mm	55 mm	65 mm	75 mm
DN 75	min. 0,8 (20 mm)	0,50	1,80	2,05	2,25	2,30	2,50	2,60	2,65

HL5100TG Drain horizontal with cast iron frame and grate, with frost-proof flap
Data

Material	PP/Cast iron
Outlet	DN75, horizontal, pluggable
Extension	Cast iron frame 190 x 190mm, cuttable in height 45-80mm
Inlet	Cast iron grate 175 x 175 mm
Stench trap	Frost-proof flap
Standard	EN 1253
Load classification	B - 12,5 t
Additional information	especially suitable for parking garages, storerooms, garbage rooms and floor areas made of mastic asphalt, for outdoor areas up to 62 m ² with a rainfall rate of 400 l / (s x ha), Recess dimensions: min. 220 x 340 mm
Including	Lid cover

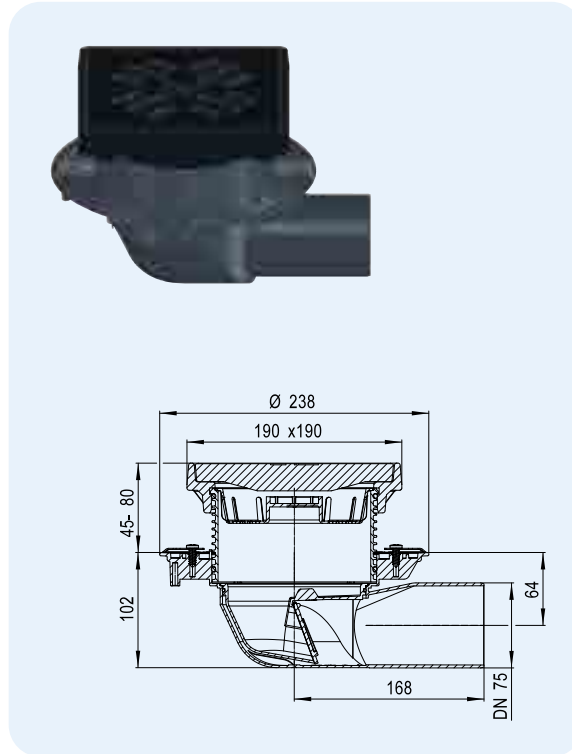

HL-No. 5100TG	Dimension DN75	Weight 12355 g	EAN +048809	Piece/package 1
------------------	-------------------	-------------------	----------------	--------------------

HL5100THG Drain like HL5100TG, but with bitumen flange
Data

Material	PP/Cast iron, pre-welded bitumen flange
Outlet	DN75, horizontal, pluggable
Extension	Cast iron frame 190 x 190mm, cuttable in height 45-80mm
Inlet	Cast iron grate 175 x 175 mm
Stench trap	Frost-proof flap
Standard	EN 1253
Load classification	B - 12,5 t
Additional information	especially suitable for parking garages, storerooms, garbage rooms and floor areas made of mastic asphalt, for outdoor areas up to 62 m ² with a rainfall rate of 400 l / (s x ha), recess dimensions: min. 220 x 340 mm
Including	Lid cover

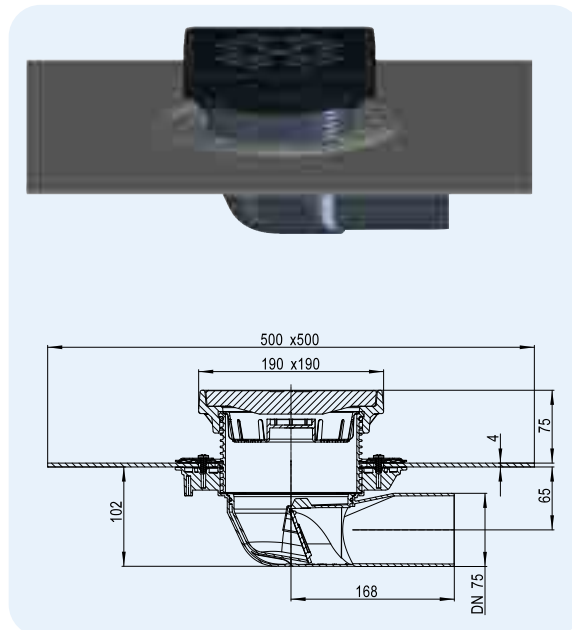

HL-No. 5100THG	Dimension DN75	Weight 13715 g	EAN +048816	Piece/package 1
-------------------	-------------------	-------------------	----------------	--------------------

Drainage table HL5100TG, HL5100THG

Tested according to EN 1253-2:2015 according to pt. 5.5.2.1 Fig. 10a) + 10b) and pt. 5.5.1.2 Fig. 9
 Drainage capacity tested according to EN 1253-2:2015 according to pt. 5.5.2.1 on downpipe 3 m

Nominal width	EN 1253	5 mm	15 mm	25 mm	35 mm	45 mm	55 mm	65 mm	75 mm
DN 75	min. 1,7 (35 mm)	0,55	1,90	3,00	3,30	3,70	3,80	3,90	4,00

Drainage capacity measured according to EN 1253-2:2015 according to clause 5.5.1.2 free draining

Nominal width	EN 1253	5 mm	15 mm	20 mm	35 mm	45 mm	55 mm	65 mm	75 mm
DN 75	min. 0,8 (20 mm)	0,75	1,85	2,50	2,85	2,95	3,10	3,20	3,25

HL3100T Balcony and terrace drain, vertical, with frost-proof flap; high capacity

Data

Material	PP
Connection dimension	DN75/110, vertical, pluggable
Frame	145 x 145mm, stainless steel, cuttable in height
Grate	Stainless steel 138 x 138
Stench trap	Frost-proof flap
Standard	EN 1253
Load classification	K 3 - max. 300 kg
Additional information	for outdoor areas up to 45 m ² (DN110) or up to 55 m ² (DN75) at a rainfall rate of 400 l/(s x ha), Recess dimensions: min. 220 x 220 mm, Core hole dimension: Ø 220 mm
Including	Supporting frame, lid cover

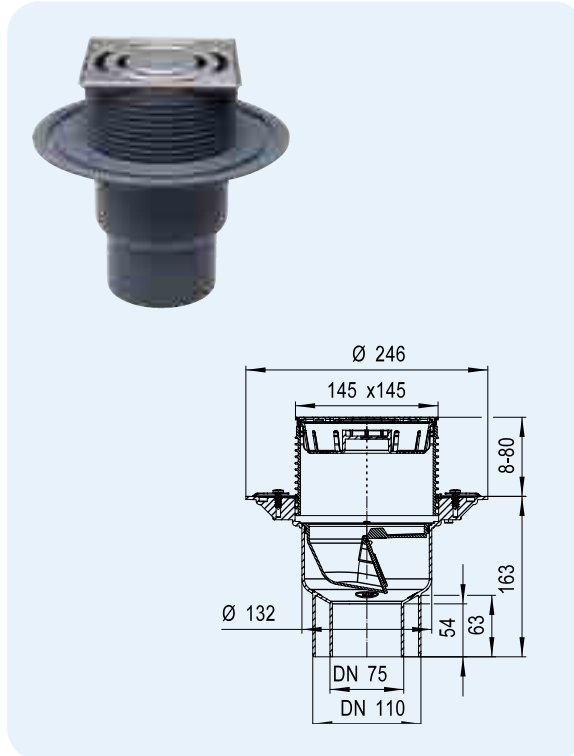

HL-No. 3100T	Dimension DN75/110	Weight 954 g	EAN +034659	Piece/package 1
-----------------	-----------------------	-----------------	----------------	--------------------

HL3100TH Balcony and terrace drain like HL3100T, but with bitumen flange

Data

Material	PP, pre-welded bitumen flange
Connection dimension	DN75/110, vertical, pluggable
Frame	145 x 145mm, stainless steel, cuttable in height
Grate	Stainless steel 138 x 138
Stench trap	Frost-proof flap
Standard	EN 1253
Load classification	K 3 - max. 300 kg
Additional information	for outdoor areas up to 45 m ² (DN110) or up to 55 m ² (DN75) at a rainfall rate of 400 l/(s x ha), for bituminous waterproofing, Recess dimensions: min. 220 x 220 mm, Core hole dimension: Ø 220 mm
Including	Supporting frame, lid cover

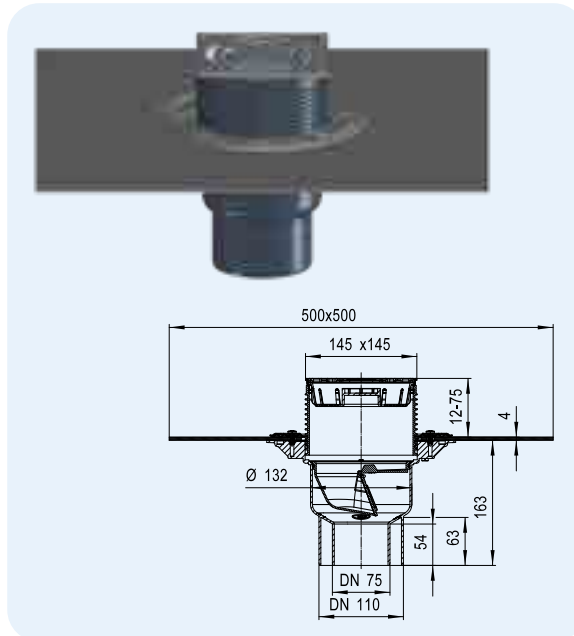

HL-No. 3100TH	Dimension DN75/110	Weight 2290 g	EAN +034666	Piece/package 1
------------------	-----------------------	------------------	----------------	--------------------

Drainage table HL3100T, HL3100TH

Tested according to EN 1253-2:2015 according to pt. 5.5.2.1 Fig. 10(a) + 10(b) and pt. 5.5.1.2 Fig. 9
Drainage capacity tested according to EN 1253-2:2015 according to pt. 5.5.2.1 on downpipe 3 m

Nominal width	EN 1253	5 mm	15mm	25 mm	35 mm	45 mm	55 mm	65 mm	75 mm
DN 75	min. 1,7 (35 mm)	0,45	1,80	2,70	2,75	2,8	2,85	2,90	2,95
DN110	min. 4,5 (35 mm)	0,40	1,40	1,75	1,80	1,90	1,95	2,00	2,05

Drainage capacity measured according to EN 1253-2:2015 according to clause 5.5.1.2 free draining

Nominal width	EN 1253	5 mm	15mm	20 mm	35 mm	45 mm	55 mm	65 mm	75 mm
DN 75	min. 0,8 (20 mm)	0,70	1,65	2,20	2,30	2,35	2,40	2,45	2,50
DN110	min. 1,4 (20 mm)	0,70	1,65	1,80	1,95	2,00	2,05	2,10	2,20

HL3100TG Drain vertical with cast iron frame and grate, with frost-proof flap

Data

Material	PP/Cast iron
Outlet	DN75/110, vertical, pluggable
Extension	Cast iron frame 190 x 190mm, cuttable in height 45-80mm
Inlet	Cast iron grate 175 x 175 mm
Stench trap	Frost-proof flap
Standard	EN 1253
Load classification	B - 12,5 t
Additional information	especially suitable for parking garages, storage or garbage rooms and floor areas made of mastic asphalt, for outdoor areas up to 48 m ² (DN110) or up to 61 m ² (DN75) with a rainfall rate of rainfall rate of 400 l/(s x ha), Recess dimensions: min. 220 x 220 mm, Core hole dimension: Ø 220 mm
Including	Lid cover

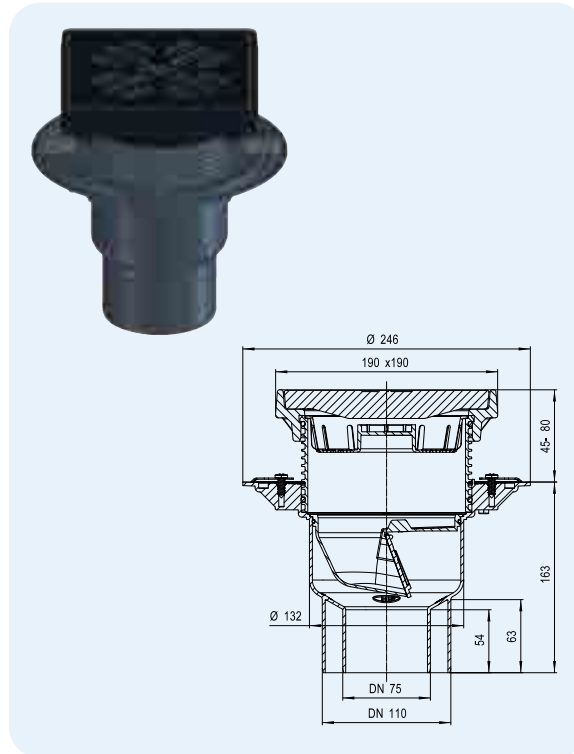

HL-No. 3100TG	Dimension DN75/110	Weight 12405 g	EAN +048755	Piece/package 1
------------------	-----------------------	-------------------	----------------	--------------------

HL3100THG Drain like HL3100TG, but with bitumen flange

Data

Material	PP/Cast iron, pre-welded bitumen flange
Outlet	DN75/110, vertical, pluggable
Extension	Cast iron frame 190 x 190mm, cuttable in height 45-80mm
Inlet	Cast iron grate 175 x 175 mm
Stench trap	Frost-proof flap
Standard	EN 1253
Load classification	B - 12,5 t
Additional information	especially suitable for parking garages, storage or garbage rooms and floor areas made of mastic asphalt, for outdoor areas up to 48 m ² (DN110) or up to 61 m ² (DN75) with a rainfall rate of 400 l/(s x ha), Recess dimensions: min. 220 x 220 mm, Core hole dimension: Ø 220 mm
Including	Lid cover

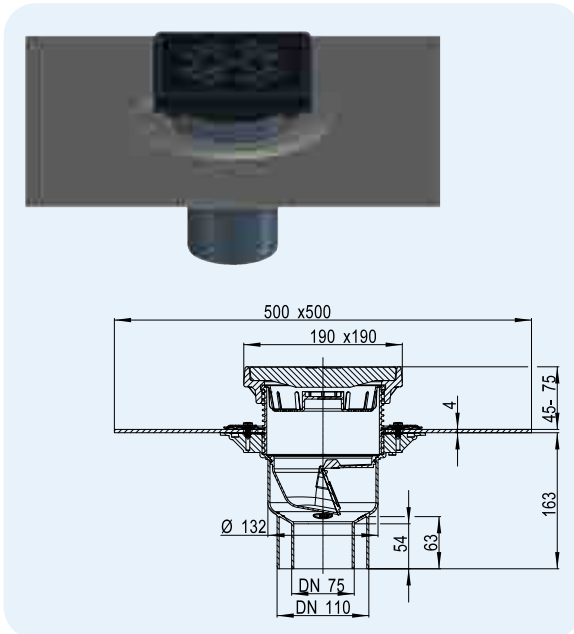

HL-No. 3100THG	Dimension DN75/110	Weight 13740 g	EAN +048762	Piece/package 1
-------------------	-----------------------	-------------------	----------------	--------------------

Drainage table HL3100TG, HL3100THG

Tested according to EN 1253-2:2015 according to pt. 5.5.2.1 Fig. 10(a) + 10(b) and pt. 5.5.1.2 Fig. 9
Drainage capacity tested according to EN 1253-2:2015 according to pt. 5.5.2.1 on downpipe 3 m

Nominal width	EN 1253	5 mm	15 mm	25 mm	35 mm	45 mm	55 mm	65 mm	75 mm
DN 75	min. 1,7 (35 mm)	0,45	1,35	2,90	3,00	3,10	3,15	3,20	3,30
DN110	min. 4,5 (35 mm)	0,55	1,90	2,10	2,20	2,30	2,35	2,40	2,50

Drainage capacity measured according to EN 1253-2:2015 according to clause 5.5.1.2 free draining

Nominal width	EN 1253	5 mm	15 mm	20 mm	35 mm	45 mm	55 mm	65 mm	75 mm
DN 75	min. 0,8 (20 mm)	0,55	1,65	2,45	2,80	2,85	2,90	2,95	3,00
DN110	min. 1,4 (20 mm)	0,40	1,30	1,95	2,15	2,20	2,25	2,30	2,40

HL Balcony and terrace drains – Accessories – Data

HL080.8E Leaf catcher

Data

Material	PP
Additional information	For non-walkable roofs. Fits to drains HL80-series, HL90 and HL310N.2

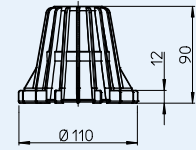

HL-No. 080.8E	Dimension Ø 110 mm	Weight 42 g	EAN +008087	Piece/package 1
------------------	-----------------------	----------------	----------------	--------------------

HL157 Leaf catcher suitable for HL3100T and HL5100T series drains

Data

Material	PP
Additional information	For non-walkable roofs. Fits to drains HL5100T and HL3100T

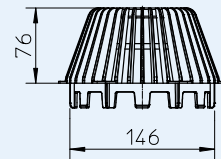

HL-No. 157	Dimension Ø 146 mm	Weight 110 g	EAN +603824	Piece/package 1
---------------	-----------------------	-----------------	----------------	--------------------

HL150 Drainage element for drains HL3100T-series and HL5100T-series

Data

Material	PP
Additional information	For drainage of rain water on the waterproofing level, e.g. inverted construction

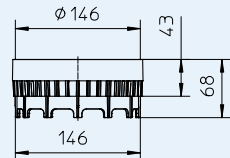

HL-No. 150	Dimension Ø 146 mm	Weight 72 g	EAN +034550	Piece/package 1
---------------	-----------------------	----------------	----------------	--------------------

HL151 Gravel guard for drains HL3100T-series and HL5100T-series

Data

Material	PP
Additional information	Flat gravel guard below slaps or wooden panels on terraces

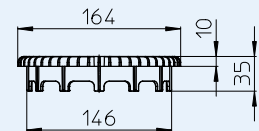

HL-No. 151	Dimension Ø 146 mm	Weight 88 g	EAN +034567	Piece/package 1
---------------	-----------------------	----------------	----------------	--------------------

HL152 Thermal insulation suitable for HL5100T drain series

Data

Material	EPS
Additional information	To be set on the drain body of HL5100T and to be fixed with 2 screws



HL-No. 152	Dimension	Weight 220 g	EAN +034574	Piece/package 1
---------------	-----------	-----------------	----------------	--------------------

HL153 Thermal insulation suitable for HL3100T drain series

Data

Material	EPS
Additional information	To be set on the drain body of HL3100T and to be fixed with 2 screws



HL-No. 153	Dimension	Weight 162 g	EAN +034581	Piece/package 1
---------------	-----------	-----------------	----------------	--------------------

HL155 Thermal insulation with integrated heating suitable for HL5100T drain series

Data

Material EPS

Additional information The thermo-insulation is fixed on the drain body 5100T by screws. The heating cable is self-regulating with 40W/M, 230V (appr. 12 - 14W cable). Overheating is impossible due to the characteristic of the cable.

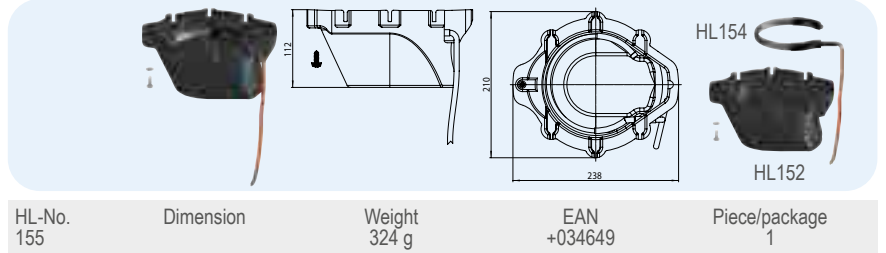

HL-No.	Dimension	Weight	EAN	Piece/package
155		324 g	+034649	1

HL156 Thermal insulation with integrated heating suitable for HL3100T drain series

Data

Material EPS

Additional information The thermo-insulation is fixed on the drain body 3100T by screws. The heating cable is self-regulating with 40W/M, 230V (appr. 12 - 14W cable). Overheating is impossible due to the characteristic of the cable.

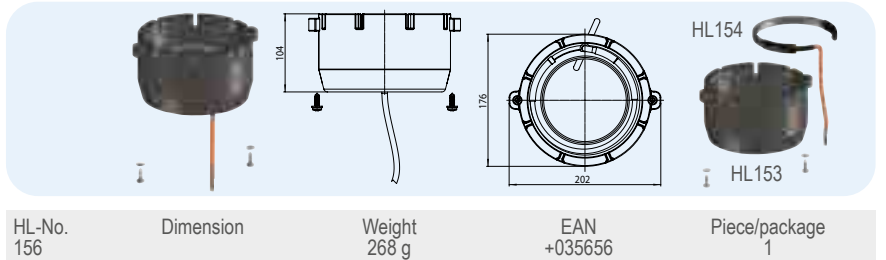

HL-No.	Dimension	Weight	EAN	Piece/package
156		268 g	+035656	1

HL180 Drainage element for drains HL80-series, HL90 and HL310N.2

Data

Material PP

Additional information For drainage of rain water on the waterproofing level, e.g. inverted construction

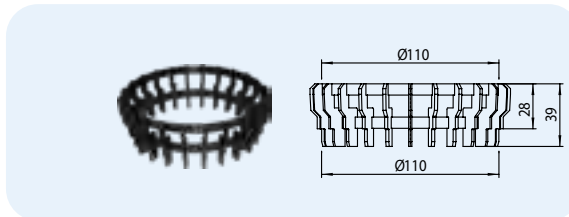

HL-No.	Dimension	Weight	EAN	Piece/package
180	Ø 110 mm	19 g	+003938	1

HL181 Gravel guard for drains HL80-series, HL90 and HL310N.2

Data

Material PP

Additional information flat gravel trap for the installation below slaps or duckboards on terraces

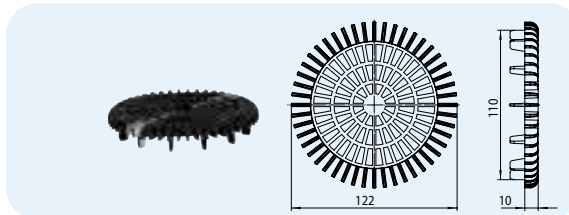

HL-No.	Dimension	Weight	EAN	Piece/package
181	DN110	44 g	+028993	1

HL82 Heating kit

Data

Additional information Self-adjusting heating set 18W / 230V. The set is equipped with a tripolar heat conductive ribbon, 1m long, insulation tape and lace. Overheating is impossible, because of the self-adjusting character of the heating. For HL80-series and HL310N.2



HL-No.	Dimension	Weight	EAN	Piece/package
82		430 g	+010820	1

HL619 Fixing brackets „FixIt“

Data

Material Stainless steel

Additional information For a tight connection between drain and extension. Fits for all balcony- and terrace drains of HL

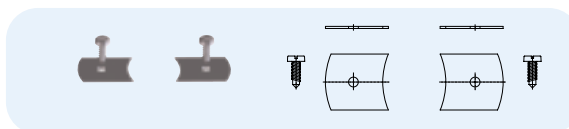

HL-No.	Dimension	Weight	EAN	Piece/package
619		54 g	+013197	1

HL Attica drains

Basic information about design and installation

Ist die Ableitung des Regenwassers durch das Flachdach mit herkömmlichen Dachabläufen nicht möglich oder sinnvoll, so bieten sich Attikaabläufe vor allem für kleine Dachflächen, wie Balkone, Terrassen und Loggien an.

Durch die Ableitung des Regenwassers außerhalb der Gebäudehülle ergeben sich vor allem im Wohnbau gewisse Vorteile:

- Keine Schwächung der Wärmedämmung, keine Kältebrücke
- Keine Geräuschbelästigung innerhalb des Gebäudes (Regenfallrohr befindet sich außerhalb des Gebäudes).
- Platzsparend: Keine Rohrführung innerhalb des Gebäudes oder unterhalb der Decke
- Keine Deckendurchdringung, daher keine statische Schwächung der Decke
- Kostengünstige Variante, weniger Material, weniger Arbeitszeit

Ablaufleistung

Im Vergleich zu herkömmlichen Dachabläufen haben Attikaabläufe eine wesentlich geringere Ablaufleistung, da hier nicht die volle Wassereinlauffläche genutzt werden kann.

Bei Warmdachkonstruktionen kann eine um mehr als die 3-fache Ablaufleistung als üblich mit Attikaabläufen, durch Situierung des Ablaufgehäuses auf Ebene der Dampfsperre, einfach erreicht werden. Dabei wird der Attikaablauf in die Dampfsperre eingebunden und mit den dafür vorgesehenen Zubehörteilen wie Einlaufelement HL164 und Aufstockelement HL85N(H) auf Abdichtebene verlängert und angeschlossen werden. Die daraus resultierende Wasserstauhöhe (Druckhöhe) ermöglicht hohe Ablaufleistungen auch mit Attikaabläufen. Ein weiterer Vorteil bei dieser Art von Planung und Montage ist die temporäre Entwässerungsmöglichkeit der Dampfsperre während der Bauphase, um die den Eintrag von Nässe und Feuchte ins Gebäude zu verhindern.

Die hydraulische Ablauftabelle mit verschiedenen Einbausituationen finden Sie unter www.hl.at

Die HL Attikaablauf-Serie HL68 besteht aus 3 verschiedenen Grundelementen (Tablets) und einer Vielzahl an Zubehörteilen, mit denen jede Art des Dachaufbaus bis hin zum Umkehrdach verwirklicht werden kann. Im Folgenden finden Sie eine Auswahl der häufigsten Konstruktionsbeispiele.

Relevant standards/directives

- ÖNORM B2501.....Drainage of buildings
- DIN 1986-100.....Drainage systems of buildings and estates
- EN 12056.....Gravity drainage systems inside of buildings
- ÖNORM B2209.....Waterproofing works
- ÖNORM B2220.....Roof waterproofings with bitumen and plastic sheetings
- ÖNORM B7209.....Waterproofings for buildings
- ÖNORM B7220.....Roofs with waterproofings

Terrace with slabs in gravel embankment, without thermal insulation

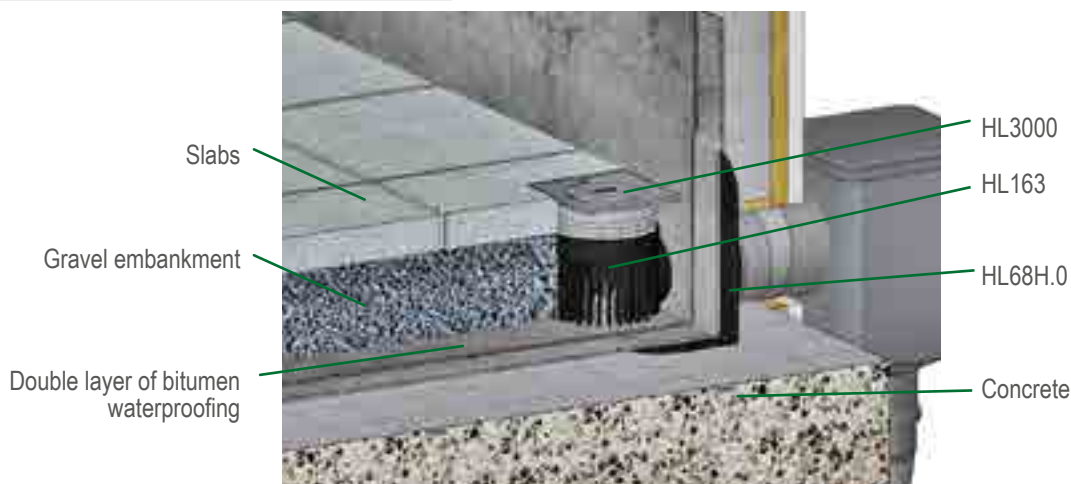

Warm roof with slabs in gravel embankment

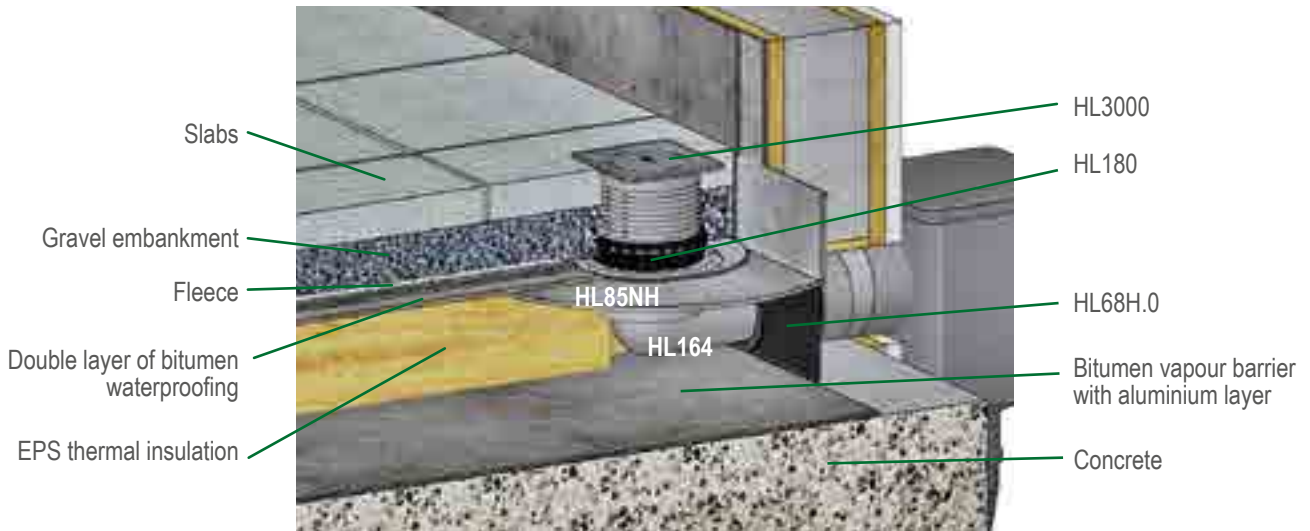

Warm roof with liquid waterproofing

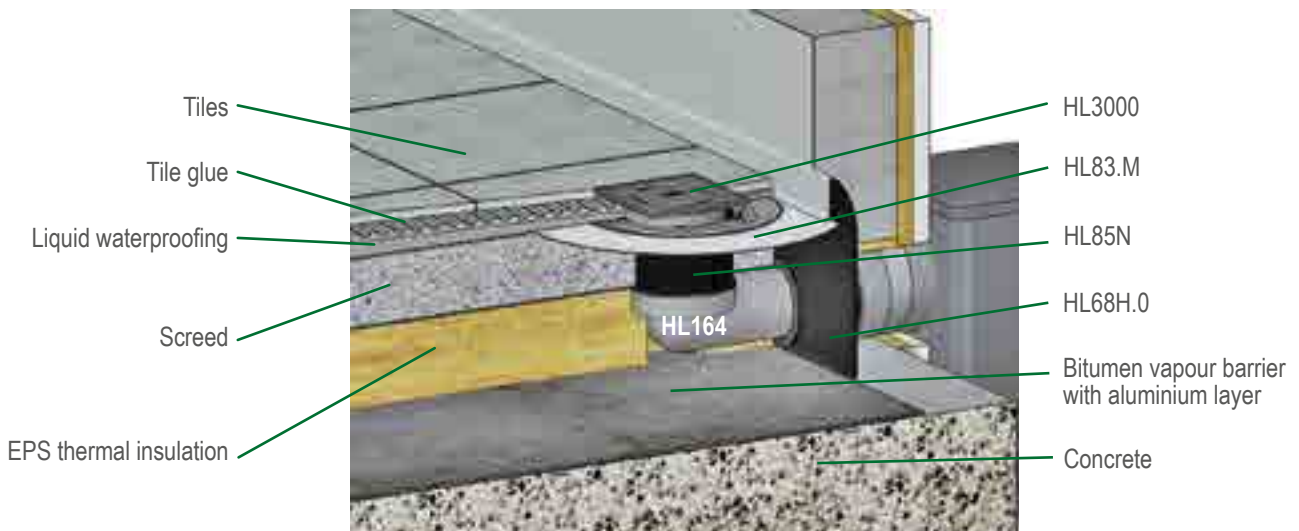

Converted roof construction

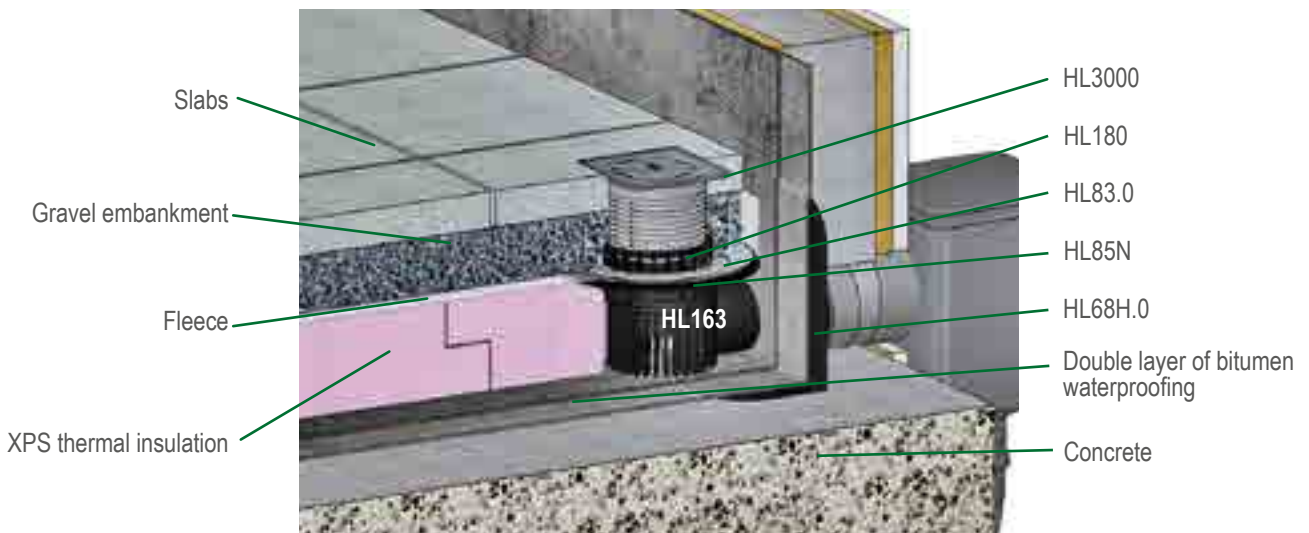

HL Attica drains - Products - Data

HL68H.0 Attica drain with bitumen membrane and PP-wastepipe

Data	
Capacity	HL68H.0/50: 0,48 l/s HL68H.0/75: 0,61 l/s HL68H.0/110: 0,71 l/s free outlet pipe and 35mm backwater height; for further information please see www.hl.at
Material	PP, bitumen
Outlet	horizontal with 2,5° incline HL68H.0/50: DN50 HL68H.0/75: DN75 HL68H.0/110: DN110
Waterproofing	with pre-welded bitumen membrane
Recommended for	bitumen waterproofings
Additional information	Notch dimension 150 x 150 mm / Ø 150 mm

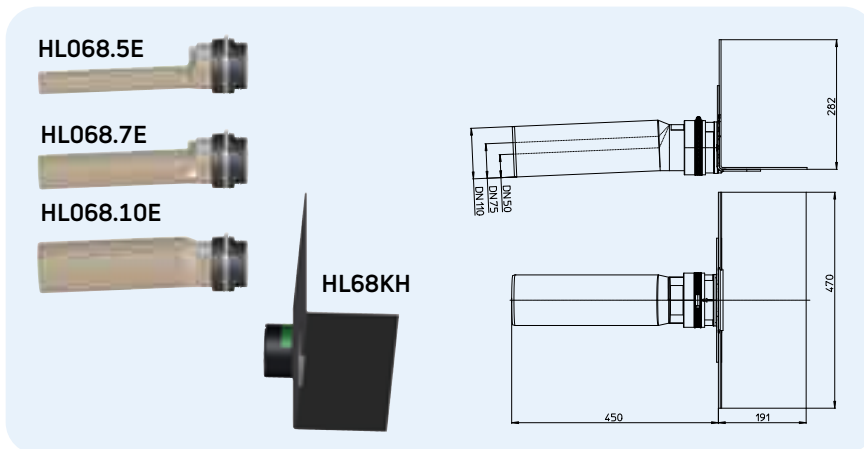

HL-No.	Dimension	Weight	EAN	Piece/package
68H.0/50	DN50	1662 g	+047529	1
68H.0/75	DN75	1748 g	+047536	1
68H.0/110	DN110	1882 g	+047512	1

HL68F.0 Attica drain with PP-flange and PP-wastepipe

Data	
Capacity	HL68F.0/50: 0,48 l/s HL68F.0/75: 0,61 l/s HL68F.0/110: 0,71 l/s free outlet pipe and 35mm backwater height; for further information please see www.hl.at
Material	PP
Outlet	horizontal with 2,5° incline HL68F.0/50: DN50 HL68F.0/75: DN75 HL68F.0/110: DN110
Waterproofing	PP, weldable with hot air
Recommended for	FPO waterproofings, based on PP
Additional information	Notch dimension 150 x 150 mm / Ø 150 mm

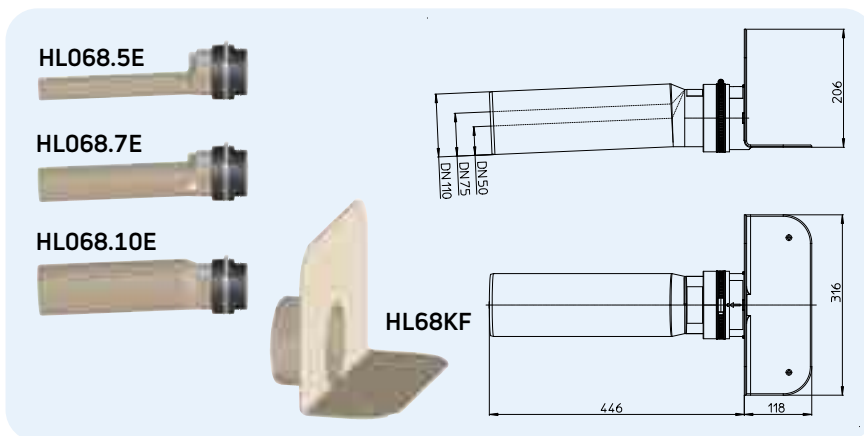

HL-No.	Dimension	Weight	EAN	Piece/package
68F.0/50	DN50	830 g	+047499	1
68F.0/75	DN75	916 g	+047505	1
68F.0/110	DN110	1050 g	+047482	1

HL68P.0 Attica drain with PVC flange and PP-wastepipe

Data	
Capacity	HL68P.0/50: 0,48 l/s HL68P.0/75: 0,61 l/s HL68P.0/110: 0,71 l/s free outlet pipe and 35mm backwater height; for further information please see www.hl.at
Material	PVC, PP
Outlet	horizontal with 2,5° incline HL68P.0/50: DN50 HL68P.0/75: DN75 HL68P.0/110: DN110
Waterproofing	PVC, weldable with hot air
Recommended for	PVC waterproofings
Additional information	Notch dimension 150 x 150 mm / Ø 150 mm

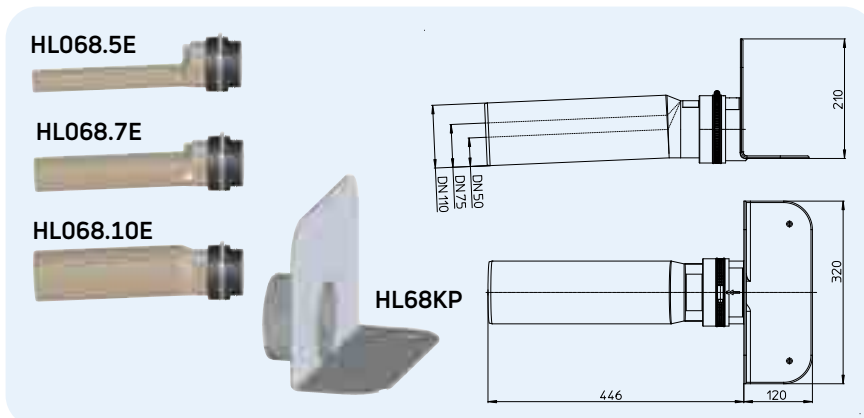

HL-No.	Dimension	Weight	EAN	Piece/package
68P.0/50	DN50	1090 g	+047598	1
68P.0/75	DN75	1176 g	+047504	1
68P.0/110	DN110	1320 g	+047581	1

Drainage capacities of HL Attica drains in combination with different attachments

Tested according to EN1253-2 : 2015 according to 5.5.3.1 Fig. 11a)

Figure 1

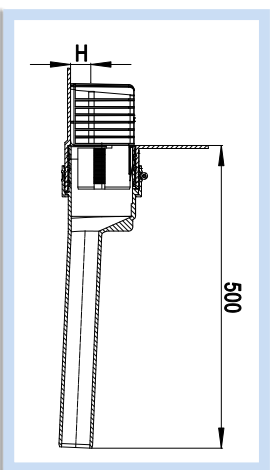

Attica drain HL68H.0/DN, HL68P.0/DN, HL68F.0/DN with leaf catcher HL068.1E or leaf catcher for emergency drainage HL068.1Ssafe

Figure 2

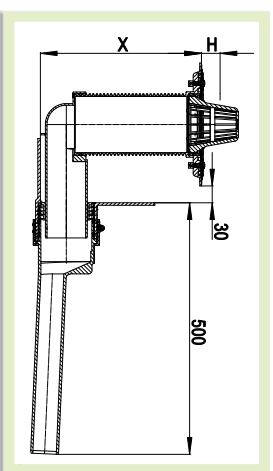

Attica drain HL68H.0/DN, HL68P.0/DN, HL68F.0/DN with inlet element HL164, extension element with sealing flange HL85N(H) and leaf catcher HL0808E

Figure 3

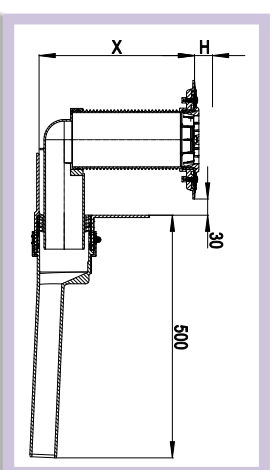

Attica drain HL68H.0/DN, HL68P.0/DN, HL68F.0/DN with inlet element HL164, extension element with sealing flange HL85N(H) and gravel catcher HL181

Figure 4

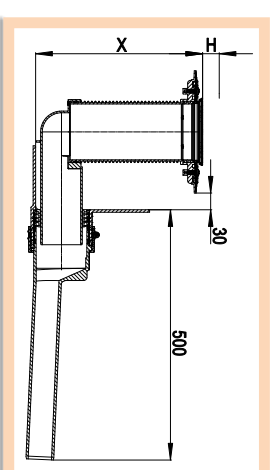

Attica drain HL68H.0/DN, HL68P.0/DN, HL68F.0/DN with inlet element HL164, extension element with sealing flange HL85N(H) and grating



SIPHONS ABLÄUFE

Tablett mit Anschlussrohr DN 50

Bild	Beschreibung	Hydraulik l/s ab Flansch																		
		5mm	15mm	25mm	38mm	45mm	55mm	65mm	70mm	75mm	80mm	90mm	100mm							
Bild 1	mit Laubfangkorb, gemessen über Flansch	-	-	-	-	-	-	-	-	-	-	-	-	-	-	-	-	-	-	-
Bild 1	mit Notentwässerung-Laubfangkorb, gemessen ab 35 mm über Flansch	0,33	0,22	0,48	0,89	1,06	1,14	1,22	1,28	1,31	1,35	1,44	1,52	1,52	1,52	1,52	1,52	1,52	1,52	1,52
Bild 2	X=110 mm mit Wärmedämmung 110mm hoch	-	-	-	1,78	-	-	-	-	-	-	-	-	-	-	-	-	-	-	-
Bild 2	X=150 mm mit Wärmedämmung 150mm hoch	-	-	-	2,13	-	-	-	-	-	-	-	-	-	-	-	-	-	-	-
Bild 2	X=200 mm mit Wärmedämmung 200mm hoch	-	-	-	2,25	-	-	-	-	-	-	-	-	-	-	-	-	-	-	-
Bild 3	X=110 mm mit Wärmedämmung 110mm hoch	-	-	-	1,8	-	-	-	-	-	-	-	-	-	-	-	-	-	-	-
Bild 3	X=150 mm mit Wärmedämmung 150mm hoch	-	-	-	1,96	-	-	-	-	-	-	-	-	-	-	-	-	-	-	-
Bild 3	X=200 mm mit Wärmedämmung 200mm hoch	-	-	-	2,16	-	-	-	-	-	-	-	-	-	-	-	-	-	-	-
Bild 4	X=110 mm mit Wärmedämmung 110mm hoch	-	-	-	1,31	-	-	-	-	-	-	-	-	-	-	-	-	-	-	-
Bild 4	X=150 mm mit Wärmedämmung 150mm hoch	-	-	-	1,39	-	-	-	-	-	-	-	-	-	-	-	-	-	-	-
Bild 4	X=200 mm mit Wärmedämmung 200mm hoch	-	-	-	1,44	-	-	-	-	-	-	-	-	-	-	-	-	-	-	-

Tablett mit Anschlussrohr DN 75

Bild	Beschreibung	Hydraulik l/s ab Flansch																		
		5mm	15mm	25mm	38mm	45mm	55mm	65mm	70mm	75mm	80mm	90mm	100mm							
Bild 1	mit Laubfangkorb gemessen über Flansch	-	-	-	-	-	-	-	-	-	-	-	-	-	-	-	-	-	-	-
Bild 1	mit Notentwässerung-Laubfangkorb gemessen ab 35 mm über Flansch	0,33	0,34	0,61	0,88	1,2	1,38	1,46	1,61	1,72	1,81	1,93	2,1	2,1	2,1	2,1	2,1	2,1	2,1	2,1
Bild 2	X=110 mm mit Wärmedämmung 110mm hoch	-	-	-	2,43	-	-	-	-	-	-	-	-	-	-	-	-	-	-	-
Bild 2	X=150 mm mit Wärmedämmung 150mm hoch	-	-	-	2,66	-	-	-	-	-	-	-	-	-	-	-	-	-	-	-
Bild 2	X=200 mm mit Wärmedämmung 200mm hoch	-	-	-	3,13	-	-	-	-	-	-	-	-	-	-	-	-	-	-	-
Bild 3	X=110 mm mit Wärmedämmung 110mm hoch	-	-	-	2,32	-	-	-	-	-	-	-	-	-	-	-	-	-	-	-
Bild 3	X=150 mm mit Wärmedämmung 150mm hoch	-	-	-	2,61	-	-	-	-	-	-	-	-	-	-	-	-	-	-	-
Bild 3	X=200 mm mit Wärmedämmung 200mm hoch	-	-	-	2,96	-	-	-	-	-	-	-	-	-	-	-	-	-	-	-
Bild 4	X=110 mm mit Wärmedämmung 110mm hoch	-	-	-	1,41	-	-	-	-	-	-	-	-	-	-	-	-	-	-	-
Bild 4	X=150 mm mit Wärmedämmung 150mm hoch	-	-	-	1,77	-	-	-	-	-	-	-	-	-	-	-	-	-	-	-
Bild 4	X=200 mm mit Wärmedämmung 200mm hoch	-	-	-	2,39	-	-	-	-	-	-	-	-	-	-	-	-	-	-	-

Tablett mit Anschlussrohr DN 110

Bild	Beschreibung	Hydraulik l/s ab Flansch																		
		5mm	15mm	25mm	38mm	45mm	55mm	65mm	70mm	75mm	80mm	90mm	100mm							
Bild 1	mit Laubfangkorb gemessen über Flansch	-	-	-	-	-	-	-	-	-	-	-	-	-	-	-	-	-	-	-
Bild 1	mit Notentwässerung-Laubfangkorb gemessen ab 35 mm über Flansch	0,32	0,42	0,71	1,05	1,38	1,8	1,98	2,2	2,48	2,9	3,28	3,28	3,28	3,28	3,28	3,28	3,28	3,28	3,28
Bild 2	X=110 mm mit Wärmedämmung 110mm hoch	-	-	-	2,4	-	-	-	-	-	-	-	-	-	-	-	-	-	-	-
Bild 2	X=150 mm mit Wärmedämmung 150mm hoch	-	-	-	2,72	-	-	-	-	-	-	-	-	-	-	-	-	-	-	-
Bild 2	X=200 mm mit Wärmedämmung 200mm hoch	-	-	-	3,11	-	-	-	-	-	-	-	-	-	-	-	-	-	-	-
Bild 3	X=110 mm mit Wärmedämmung 110mm hoch	-	-	-	2,3	-	-	-	-	-	-	-	-	-	-	-	-	-	-	-
Bild 3	X=150 mm mit Wärmedämmung 150mm hoch	-	-	-	2,65	-	-	-	-	-	-	-	-	-	-	-	-	-	-	-
Bild 3	X=200 mm mit Wärmedämmung 200mm hoch	-	-	-	2,96	-	-	-	-	-	-	-	-	-	-	-	-	-	-	-
Bild 4	X=110 mm mit Wärmedämmung 110mm hoch	-	-	-	1,41	-	-	-	-	-	-	-	-	-	-	-	-	-	-	-
Bild 4	X=150 mm mit Wärmedämmung 150mm hoch	-	-	-	1,56	-	-	-	-	-	-	-	-	-	-	-	-	-	-	-
Bild 4	X=200 mm mit Wärmedämmung 200mm hoch	-	-	-	2,39	-	-	-	-	-	-	-	-	-	-	-	-	-	-	-

HL Attica drains - Accessories - Data

HL068.1E Leaf catcher for attica drains series HL68

Data	
Material	PP
Additional information	Fits to all attica drains 68-series

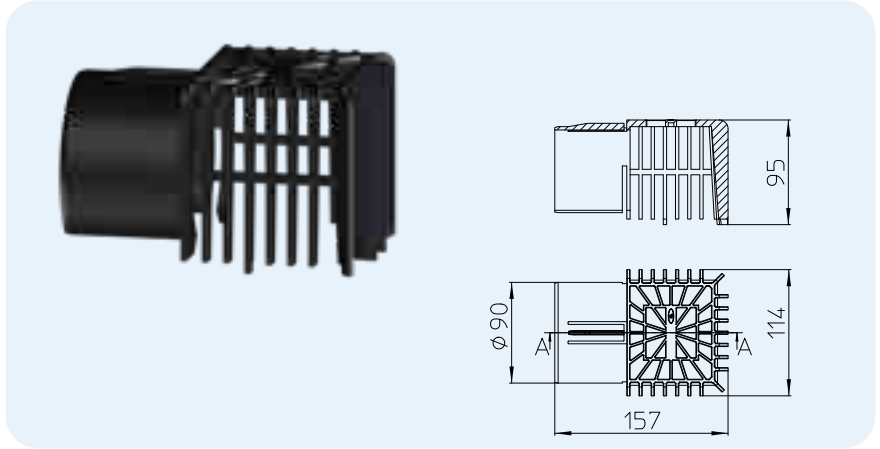

HL-No.	Dimension	Weight	EAN	Piece/package
068.1E		618 g	+047406	1

HL068.1Safe Leaf catcher „emergency drainage“ for attica drains series HL68

Data	
Material	PP
Additional information	With 35mm overflow edge for emergency drainage; Fits to all attica drains 68-series

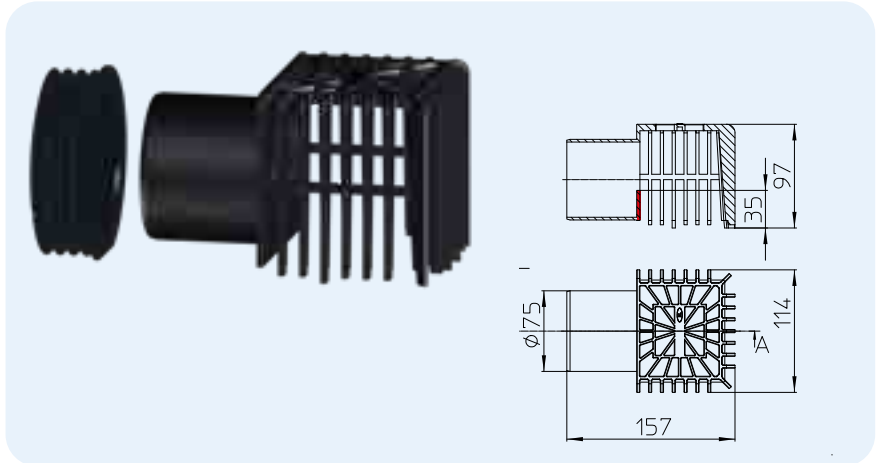

HL-No.	Dimension	Weight	EAN	Piece/package
068.1Safe		170 g	+047420	1

HL163 Drain element for attica drains series HL68

Data	
Material	PP
Additional information	Fits to all attica drains 68-series; for drainage of converted roof constructions

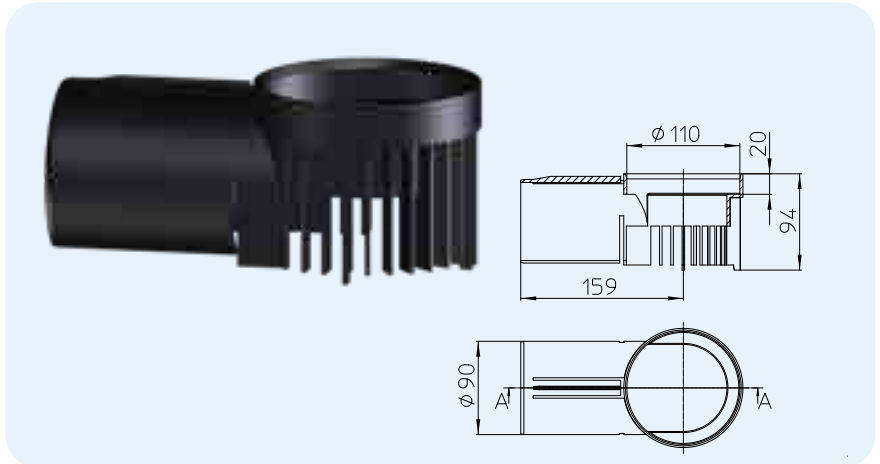

HL-No.	Dimension	Weight	EAN	Piece/package
163		152 g	+047376	1

HL163Safe Drain element „emergency drainage“ for attica drains series HL68

Data

Material	PP
Additional information	Fits to all attica drains 68-series; for emergency drainage of converted roofs constructions (with 35mm overflow edge)

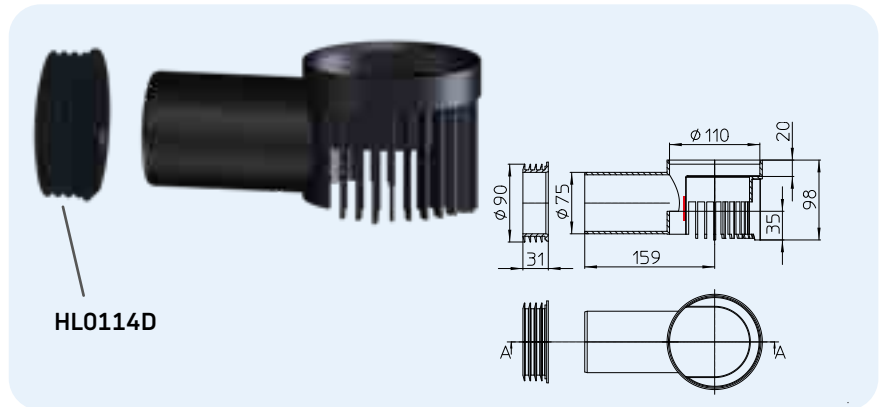

HL-No. 163Safe	Dimension	Weight 221 g	EAN +047383	Piece/package 1
-------------------	-----------	-----------------	----------------	--------------------

HL164 Inlet element for attica drains series HL68

Data

Material	PP
Additional information	For warm roof constructions

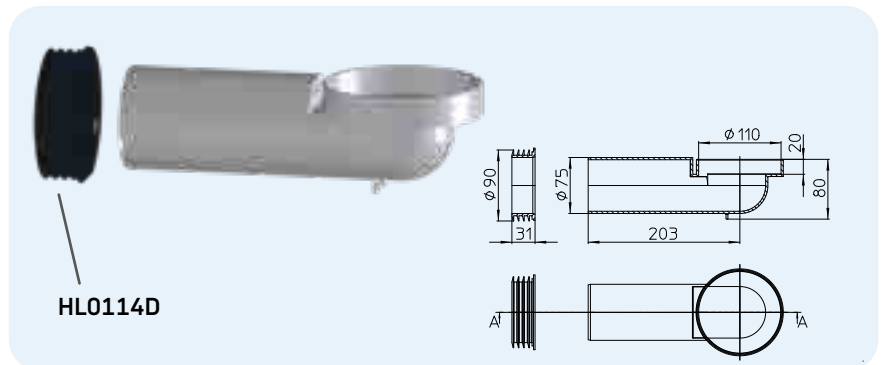

HL-No. 164	Dimension	Weight 226 g	EAN +047390	Piece/package 1
---------------	-----------	-----------------	----------------	--------------------

HL163.1 Drainage ring for HL164

Data

Material	PP
Additional information	Drainage ring for HL164

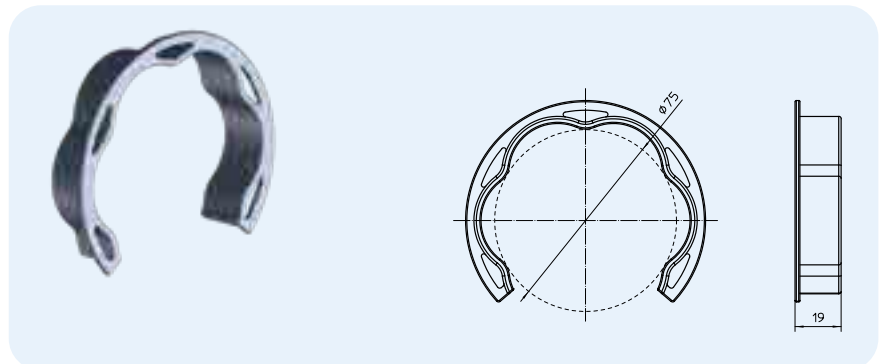

HL-No. 163.1	Dimension DN 75	Weight	EAN +605031	Piece/package 1
-----------------	--------------------	--------	----------------	--------------------



SIPHONS ABLÄUFE

Ø 354

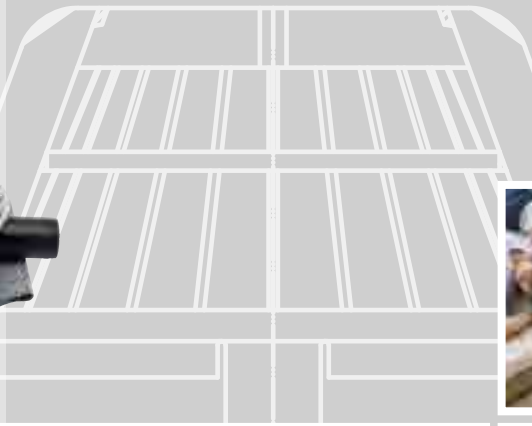

101



HL Drains

13. Floor

13



HL Floor drains

Basic information about design and installation

Floor drains serve as central drainage of floor surfaces. To reach a satisfying result, aesthetic and functional, the plumber has to care for some important topics. The coordination of the different craftsmen (designer, construction company, plumber, tiler..) is the biggest challenge for the plumber. Therefore please notice already during planning and design, some topics:

▲ **Function:**

The question, how the drain is finally used, decides already during design of the drainage system the choice of the gully. Generally one differs between permanent use (places, where splashing water occurs, e.g. shower) and irregular use (e.g. as safety drain in laundry rooms).

▲ **Stench trap:**

Especially at rarely used drain spots one has to avoid, that stench rises from the sewage system. A classic solution is to use a drain with additional side inlet (HL300, HL304). A regularly used drain spot (e.g. washing basin) makes sure, that the trap cannot become dry. In this case the drain should be constructed backwater save, so that the wastewater from the basin cannot overflow on the floor. Also the inlet should be siphoned in the drain itself. Another solution for this problem is the wellknown drain-series „Primus“ of HL. These drains have a normal water siphon and a mechanical trap. A floating body is part of a normal water trap. When the water evaporates in the trap (or is sucked out by vacuum in the sewage system), the floating body sinks on the mouth of the drain and closes it.

▲ **Primusblue system**

The Primusblue is a combined odor trap with sealing water and mechanical odor barrier, which provides absolute odor-tightness and even more protection against unpleasant odors from the sewer. With a tightness at positive pressure up to +800 Pascal and negative pressure up to 400 Pascal Primusblue offers greater safety compared to conventional water odor seals with 50 mm barrier water. Another benefit is the function of backflow tightness up to a pressure of 0.5 mWs. The backflow of wastewater in the case of unfavorably laid pipes (e.g. from the bathtub or during backwashing in the swimming pool) is effectively prevented. (ÖNORM B2501)

▲ **Capacity:**

The test procedure for evaluating the drain capacity for floor drains is made according EN 1253-1: 2015 with 20 mm impounded water above the grate. If floor drains are used for barrier-free showers, the plumber should take care, that the flow rate is higher than the water inlet from the shower, to avoid water running into the dry area of the bathroom.

▲ **Waterproofing:**

To avoid leakage water to get into the floor construction, the floor drain has to be connected to the on-site waterproofing. **Attention: Gaps between tiles are not waterproof!** In most cases the waterproofing (mostly liquid compounds) is located directly under the tiles. HL floor drains are equipped with flanges, on which the plumber may install the right sealing kit. The installer, together with the tiler, should decide, which. To apply the waterproofing material directly on the flange, is not waterproof.

▲ **Sound protection:**

Please see chapter „accessories“ on page 268

▲ **Installation:**

When the floor drain is mounted, the level of the flange should be below the level of the screed, so that a sufficient incline to the drain is possible. Attention: The height of the drain body is not the minimum height of the screed.

▲ **Design:**

Depending on taste and function, you may choose different types of grates and extensions. The plumber should first talk to the enduser, which one he prefers, as a subsequent change is not always possible.

Relevant standards/directives

ÖNORM B2501	Drainage of buildings
DIN 1986-100	Drainage systems for buildings and estates
EN 12056.....	Gravity drainage systems inside of buildings
ÖNORM B2207	Tiling works
EN1253.....	Drains for buildings

Selection of the convenient drain

Selective criteria	Requirements	Product	
		horizontal outlet	vertical outlet
Capacity	To find the right choice, one has to know, which maximum wastewater quantity should be drained off.	up to 0,4 l/s → HL90PrblueD up to 0,45 l/s → HL90Prblue (-3000) up to 0,55 l/s → Series HL510, Series HL80.1, HL541(I) Series HL300, HL304 up to 0,8 l/s → HL540(I), HL5100Pr up to 1 l/s → HL5100 up to 1,12 l/s → Series HL70 up to 1,5 l/s → HL72.1(N)	up to 0,5 l/s → Series HL80, Series HL310Prblue up to 0,67 l/s → Series HL310 up to 0,8 l/s → HL3100Pr from 1,25 l/s up to 1,4 l/s → HL3100 up to 1,8 l/s → Series HL317
Existing floor height	<p>At drains with horizontal outlet the floor height is an important criteria.</p> <p>Floor construction concrete floor - top edge of the screed</p> <p> $\geq 70 \text{ mm} \leq 90 \text{ mm}$ $\geq 90 \text{ mm} \leq 110 \text{ mm}$ $\geq 90 \text{ mm} \leq 250 \text{ mm}$ $\geq 110 \text{ mm} \leq 160 \text{ mm}$ $\geq 160 \text{ mm} \leq 180 \text{ mm}$ $\geq 180 \text{ mm}$ </p> <p>At drains with vertical outlet the drain body lies on the concrete floor and therefore mostly needs an extension element with flange, to reach the top edge of the screed.</p>	<p>Height of the drain body:</p> <p>Series HL90, HL541(i) = 62 mm Series HL510 = 79 mm, Series HL540 = 80 mm Series HL5100 = 97 mm Series HL72.1 = 150 mm Series HL70 = 173 mm</p>	<p>Series HL80, HL310 → HL85N Series HL3100 → HL8500 Series HL317 → HL350.1</p>
Waterproofing	<p>The use of a sealing kit, which fits to the on-site waterproofing, is absolutely necessary for a watertight connection.</p> <p>Kind and material of the waterproofing:</p> <p>For under-tile waterproofings, e.g. 2-component-epoxy resins</p> <p>For EPDM-sheetings, based on bitumen, for bitumen coatings and for welding of bitumen sheetings</p> <p>Welding of bitumen sheetings</p>	<p>Series HL70, HL80, HL90, HL300, HL310, HL510 → HL83.M Series HL72.1 and HL317 → HL84.M HL540 and HL541 series → Waterproofing included! Series HL3100 and HL5100 → HL8300.M</p> <p>Series HL70, HL80, HL90, HL300, HL310, HL510 → HL83 Series HL72.1 and HL317 → HL84 Series HL3100 and HL5100 → HL8300</p> <p>HL83H, HL8300.H Series HL70.....→ HL83H Instead of series HL72.1 or HL317 → HL72.1H and HL317H Series HL3100 and HL5100 → HL8300H</p>	

HL Floor drains – Sectional drawings

Floor drain horizontal with integration into the composite waterproofing e.g. tiled shower

HL540

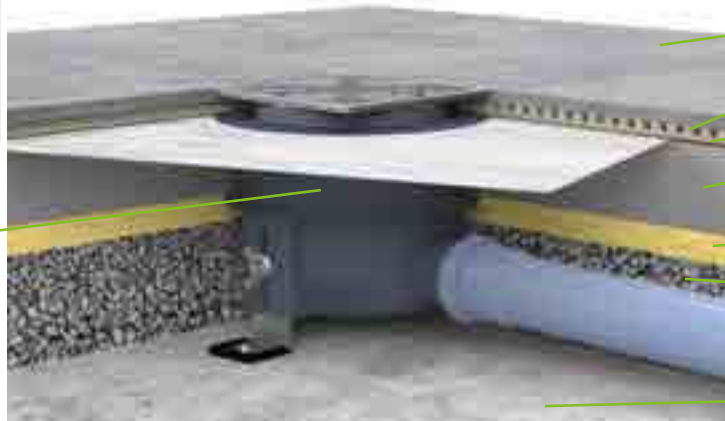

- Tile covering
- Tile adhesive
- Composite waterproofing
- Screed
- Impact sound insulation
- Levelling fill
- Concrete

Floor drain horizontal with integration into the composite waterproofing 2-part design with extension element HL85N

HL510N-3000

HL85N

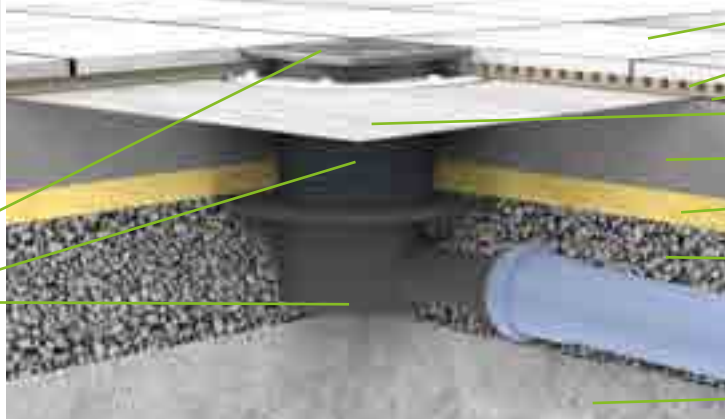

- Tile covering
- Tile adhesive
- Composite waterproofing
- HL83.M
- Screed
- Impact sound insulation
- Levelling fill
- Concrete

Floor drain vertical with integration in bitumen and composite waterproofing

HL83.M

HL3000.1

HL85N

HL310KH

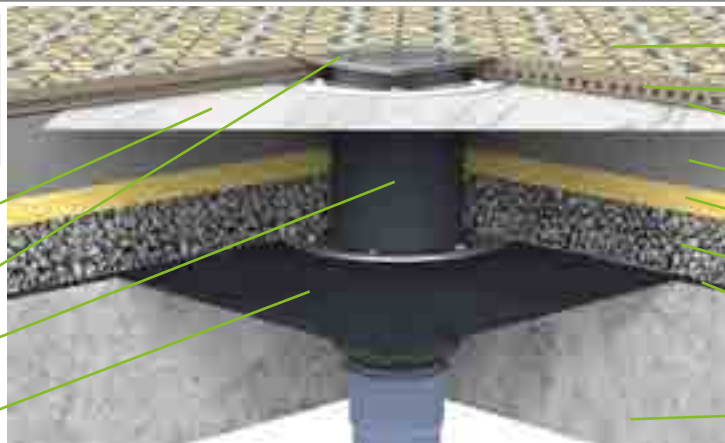

- Tile covering
- Tile adhesive
- Composite waterproofing
- Screed
- Impact sound insulation
- Levelling fill
- Bitumen waterproofing
- Concrete

HL Floor drains – Installation



1. Fill in concrete and level to the height of the lid cover



2. Wait, until the concrete is set



3. Remove lid cover, clean flange and insert the gasket



4. Apply the waterproofing membrane



5. Fix the stainless steel ring by screwing



6. The sealing kit is below the concrete level



7. Apply the liquid waterproofing



8. Smooth the membrane



9. Apply the liquid waterproofing on the whole wet area.



10. The sealing kit is completely below the concrete level



11. Cut the extension



12. Insert the extension without O-ring. Lay the tiles.

HL Floor drains – Products – Overview

Drains



Product	HL90Prblue	HL90PrblueD	HL510(N)(Prblue)	HL80.1	HL90Prblue-3020	HL300
Description	Drain horizontal DN40/50	Drain horizontal DN40, with fleece flange	Drain horizontal DN40/50	Drain 50/75 with convertible ball-joint outlet	Drain horizontal DN40/50	Drain horizontal DN50 with side inlet
Function	Extremely flat, for flat floor constructions with Primus blue trap	Especially for under-tile waterproofings, with Primus blue trap	Standard drain, flat, also available with Primus blue trap	For horizontal and vertical connection	Extreme flat with tilable grate and Primus blue trap	With side inlet, which cares for a full water trap. The integrated backwater protector prevents foam to leak through the grate.

Extensions

Product data see chapter sealing kits / extensions



Product	HL340N	HL3400	HL350	HL85N
Description	Extension	Extension	Extension	Extension with flange
Function	For elongating the extension, fits to drains of series HL90, HL510, HL80, HL300, HL70, HL310, HL304	For elongating the extension, fits to drains of series HL3100 and HL5100	For elongating the extension, fits to drains of series HL72.1 and HL317	For the adjustment of the drain to the waterproofing level, fits to drains of series HL90, HL510, HL80, HL300, HL70, HL310, HL304

HL Floor drains – Products – Overview



HL510(N)(Prblue)-3020	HL5100(Pr)	HL310(N)(Prblue)-3020	HL72.1N	HL310(N)(Prblue)	HL3100(Pr)	HL317
Drain horizontal DN40/50	Floor drain horizontal DN50/75, high capacity	Drain vertikal DN50/75/110	Floor drain horizontal DN75/110, high capacity	Floor drain vertical DN50/75/110	Ablauf senkrecht DN50/75/110	Floor drain vertical DN50/75/110
Standard drain with tilable extension and optional Primus blue trap	For high capacity reasons, also available with Primus trap	With tilable grate and optional Primus blue trap	For high capacity reasons	For outlet pipes below the concrete floor, also available with Primus blue trap	For outlet pipes below the concrete floor, with high capacity, also available with Primus blue trap	For outlet pipes below the concrete floor, with high capacity.



HL8500	HL350.1(.0)	HL350.1H	HL3200
Extension with flange	Extension with Sealing flange	Extension with bitumen flange	Extension with stainless steel frame and grate
For the adjustment of the drain to the waterproofing level, fits to drains of series HL3100 and HL5100	To adjust the drain to the waterproofing level, fitting to floor drain series HL72.1 and HL317	To adjust the drain to the level of under-tile waterproofings, fitting to floor drain series HL72.1 and HL317	To change from standard extension to extension with stainless steel frame, e.g. when you use „design“-grates. Fitting to floor drain series HL90, HL510, HL80, HL300, HL70, HL310, HL304

HL Floor drains – Products – Overview

Accessories



Product	HL3020	HL37N	HL3000	HL37NP	HL38N	HL39G	HL3910	HL3911
Description	Tilable extension	Standard extension	Extension „Klick-Klack“	Extension with PVC-collar	Round extension	Cast iron extension	Extension „Klick-Klack“	Extension „Klick-Klack“ with screwable grate
Function	Extension fits to drain bodies HL70K-3020, HL80K-3020, HL90K-3020, HL300K-3020, HL304K-3020, HL310K-3020 and HL510K-3020	Standard extension, fitting to floor drain series HL90, HL510, HL80, HL300, HL70, HL310, HL304	Standard extension with stainless steel frame, fitting to floor drain series HL90, HL510, HL80, HL300, HL70, HL310, HL304	To connect PVC floor coverings, fitting to floor drain series HL90, HL510, HL80, HL300, HL70, HL310, HL304	Extension with round cover plate, fitting to floor drain series HL90, HL510, HL80, HL300, HL70, HL310, HL304	Usage with high load or to connect hot bitumen floor coverings, fitting to floor drain series HL90, HL510, HL80, HL300, HL70, HL310, HL304	Standard extension, fitting to floor drain series HL3100 and HL5100	Standard extension, fitting to floor drain series HL3100 and HL5100

Sealing kits



Product data see chapter sealing kits / extensions

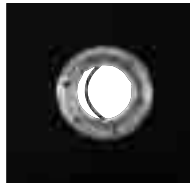

Product	HL83.0	HL83	HL83.M	HL83.H	HL8300.0
Description	Sealing kit without sheeting	Sealing kit with EPDM sheeting	Sealing kit with textile coated membrane	Sealing kit with bitumen collar	Sealing kit without sheeting
Function	For clamping of on-site sheetings, fitting to floor drain series HL70, HL80, HL90, HL300, HL304, HL310, HL510	For bitumen coatings and EPDM sheetings, fitting to floor drain series HL70, HL80, HL90, HL300, HL304, HL310, HL510	For under-tile waterproofings, fitting to floor drain series HL70, HL80, HL90, HL300, HL304, HL310, HL510	For bitumen based water-proofings or coatings, fitting to floor drain series HL70, HL80, HL90, HL300, HL304, HL310, HL510	For clamping of on-site sheetings, fitting to floor drain series HL3100 and HL5100

HL Floor drains – Products – Overview

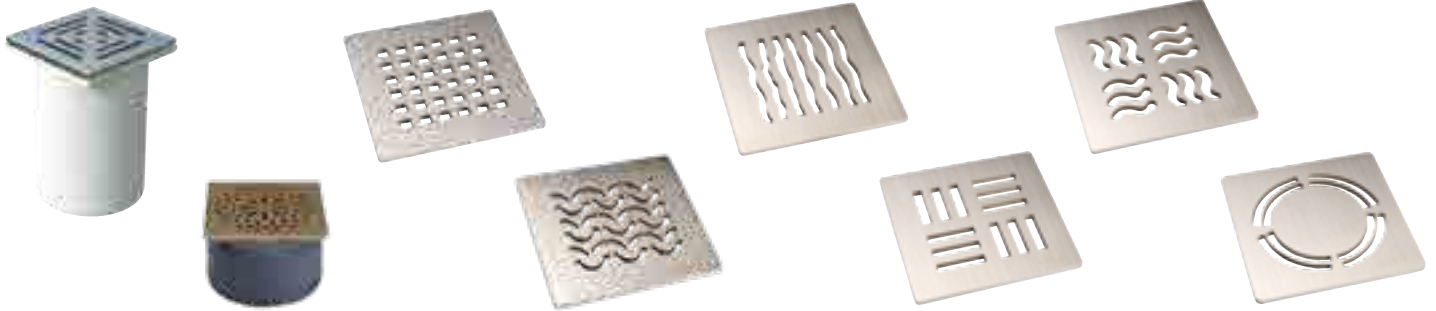

HL66(Q)	HL3928	HL3120	HL3121	HL3123	HL3124	HL3125	HL3127
Extension	Extension with design-grate „Hamam“	Design-grate „Quadra“	Design-grate „Seine“	Design-grate „Orinoco“	Design-grate „Nil“	Design-grate „Yukon“	Design-grate „Primus Design“
Stainless steel grate with high request on design and stability, fitting to floor drain series HL72.1 and HL317	Extension for floor drain with golden frame and grate, design „Hamam“. Fits to floor drain series HL5100 and HL3100.	Stainless steel grate with high request on design and stability, fitting to floor drain series HL90, HL510, HL80, HL300, HL70, HL310, HL304	Stainless steel grate with high request on design and stability, fitting to floor drain series HL90, HL510, HL80, HL300, HL70, HL310, HL304	Stainless steel grate with high request on design and stability, fitting to floor drain series HL90, HL510, HL80, HL300, HL70, HL310, HL304	Stainless steel grate with high request on design and stability, fitting to floor drain series HL90, HL510, HL80, HL300, HL70, HL310, HL304	Stainless steel grate with high request on design and stability, fitting to floor drain series HL90, HL510, HL80, HL300, HL70, HL310, HL304	Stainless steel grate with high request on design and stability, fitting to floor drain series HL90, HL510, HL80, HL300, HL70, HL310, HL304



HL8300	HL8300.M	HL8300.H	HL84.0	HL84	HL84.M
Sealing kit with EPDM sheeting	Sealing kit with textile coated membrane	Sealing kit with bitumen collar	Sealing kit without sheeting	Sealing kit with EPDM sheeting	Sealing kit with textile coated membrane
For bitumen coatings and EPDM sheetings, fitting to floor drain series HL3100 and HL5100	For under-tile waterproofings, fitting to floor drain series HL3100 and HL5100	For bitumen based waterproofings or coatings, fitting to floor drain series HL3100 and HL5100	For clamping of on-site sheetings, fitting to floor drain series HL317 and HL72.1	For bitumen coatings and EPDM sheetings, fitting to floor drain series HL317 and HL72.1	For under-tile waterproofings, fitting to floor drain series HL317 and HL72.1

HL Floor drains – Products – Data

HL80.1 Floor drain with convertable outlet

Data

Capacity	0,5 l/s
Material	PP,PE, stainless steel V2A
Outlet	DN50/75 stepless convertable from horizontal to vertical, Material PE, pluggable and weldable
Extension	123 x 123 mm, cuttable in height
Grate	Stainless steel grate 115 x 115 mm
Stench trap	Height of water trap 50 mm
Standard	EN 1253
Load classification	K 3 – max. 300 kg
Recommended for	Floor drainage inside the building
Additional information	temperature-resistant up to 85 °C
Including	Supporting frame, lot cover

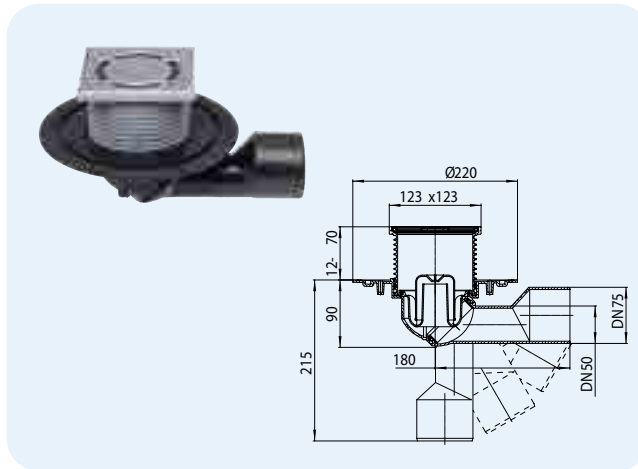

HL-No. 80.1	Dimension DN50/75	Weight 625 g	EAN +700813	Piece/package 1
----------------	----------------------	-----------------	----------------	--------------------

HL80.1H Floor drain with bitumen collar

Data

Capacity	0,5 l/s
Material	PP,PE, premounted bitumene membrane, stainless steel V2A
Outlet	DN50/75 stepless convertable from horizontal to vertical, Material PE, pluggable and weldable
Extension	123 x 123 mm, cuttable in height
Grate	Stainless steel grate 115 x 115 mm
Stench trap	Height of seal water 50 mm
Standard	EN 1253
Load classification	K 3 – max. 300 kg
Recommended for	Bitumen waterproofings
Additional information	temperature-resistant up to 85 °C
Including	Supporting frame, lot cover

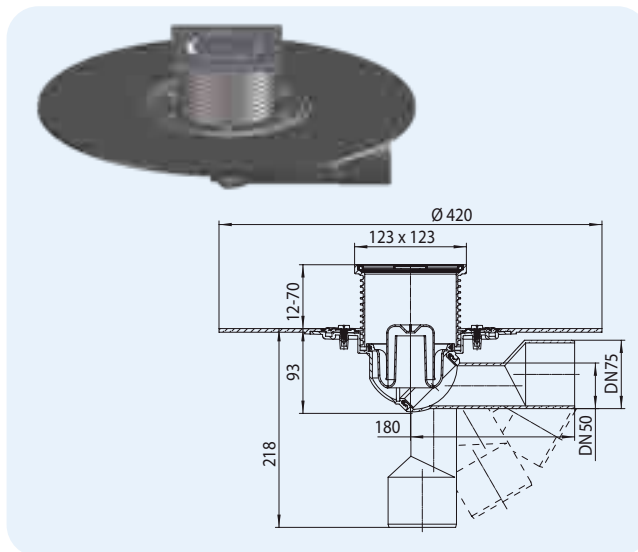

HL-No. 80.1H	Dimension DN50/75	Weight 1195 g	EAN +701810	Piece/package 1
-----------------	----------------------	------------------	----------------	--------------------

HL80.1R Floor drain with round cover plate

Data

Capacity	0,5 l/s
Material	PP,PE, stainless steel V2A
Outlet	DN50/75 stepless convertible from horizontal to vertical, Material PE, pluggable and weldable
Extension	Stainless steel frame Ø 133 mm, cuttable in height
Grate	Stainless steel cover plate Ø 112 mm
Stench trap	Height of seal water 50 mm
Standard	EN 1253
Load classification	K 3 – max. 300 kg
Recommended for	Barrier-free showers with round cover plate
Additional information	temperature-resistant up to 85 °C
Including	Supporting frame, lot cover

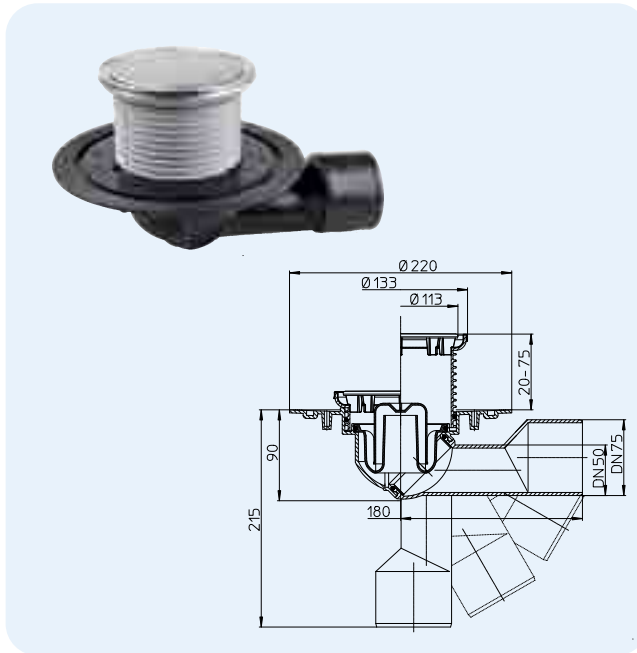

HL-No. 80.1R	Dimension DN50/75	Weight 650 g	EAN +004591	Piece/package 1
-----------------	----------------------	-----------------	----------------	--------------------

HL80.2 Floor drain with standpipe

Data

Capacity	0,5 l/s
Material	PP, PE
Outlet	DN50/75 stepless convertible from horizontal to vertical, Material PE, pluggable and weldable
Extension	100 x 100 mm, cuttable in height
Grate	94 x 94 mm cover
Stench trap	Height of seal water 30 mm
Standard	EN 1253
Load classification	K 3 – max. 300 kg
Recommended for	Brick-built bathtubs, longer standpipe on request!
Additional information	temperature-resistant up to 85 °C
Including	Lot cover, standpipe HL515 with 10 cm

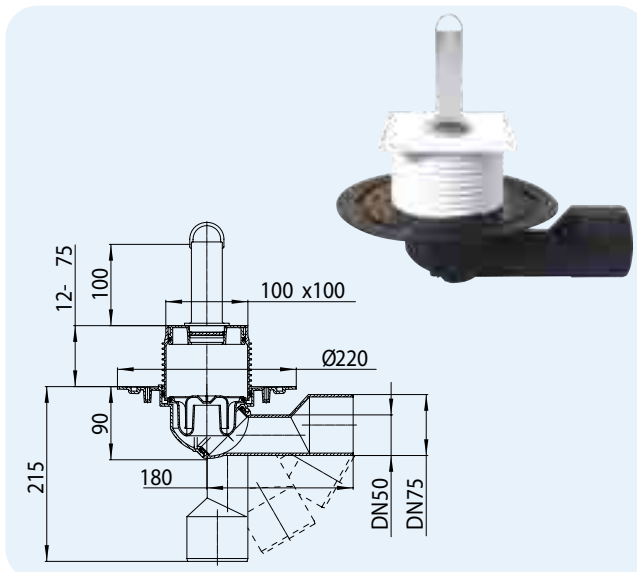

HL-No. 80.2	Dimension DN50/75	Weight 535 g	EAN +700820	Piece/package 1
----------------	----------------------	-----------------	----------------	--------------------

HL300 Floor drain with side inlet and backwater protector

Data

Capacity	0,5 l/s
Material	PE, stainless steel V2A
Outlet	horizontal DN50, side inlet DN40/50, Connections pluggable and weldable
Extension	123 x 123 mm, cuttable in height
Grate	Stainless steel grate 115 x 115 mm
Stench trap	Height of seal water 50 mm
Standard	EN 1253
Load classification	K 3 – max. 300 kg
Additional information	with backwater protector, temperature-resistant up to 85 °C
Including	Supporting frame, lot cover

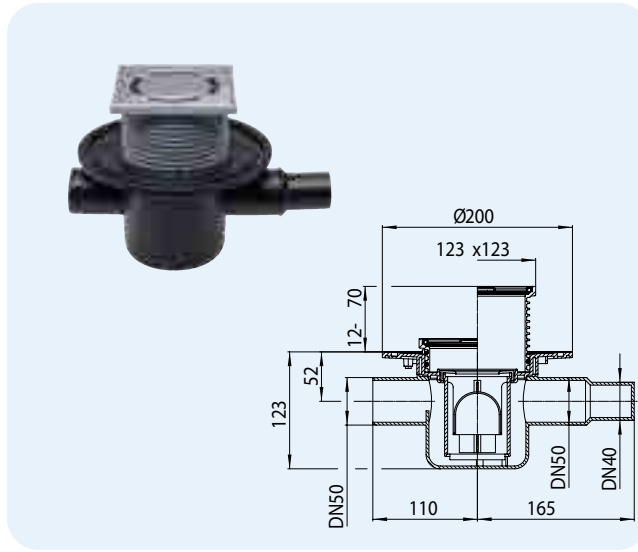

HL-No. 300	Dimension DN50	Weight 935 g	EAN +703005	Piece/package 1
---------------	-------------------	-----------------	----------------	--------------------

HL303K Floor drain body with 3 side inlets

Data

Capacity	0,5 l/s
Material	PE
Outlet	horizontal DN50, 3 side inlets, connections pluggable and weldable
Grate	with Accessories: Plug HL306 or with Trap seal assembly HL307
Stench trap	Height of seal water 35 mm
Recommended for	Central drainage and siphoning for the whole bathroom
Additional information	no connection to the waterproofing
Including	Lot cover

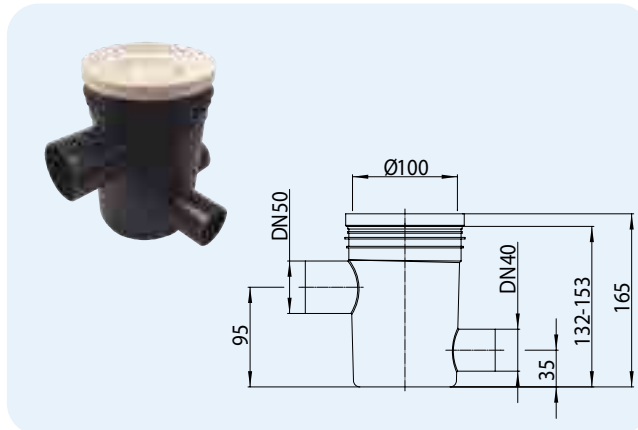

HL-No. 303K	Dimension DN50	Weight 230 g	EAN +703036	Piece/package 1
----------------	-------------------	-----------------	----------------	--------------------

HL304 Floor drain with 3 side inlets

Data

Capacity	0,5 l/s
Material	PE, stainless steel V2A
Outlet	horizontal DN50, 3 side inlets DN40, connections pluggable and weldable
Extension	123 x 123 mm, cuttable in height
Grate	Stainless steel grate 115 x 115 mm
Stench trap	Height of seal water 50 mm
Standard	EN 1253
Load classification	K 3 – max. 300 kg
Recommended for	Central drainage and siphoning of the whole bathroom, the inlets care for enough water in the trap
Additional information	with backwater protector, temperature-resistant up to 85 °C
Including	Supporting frame, lot cover

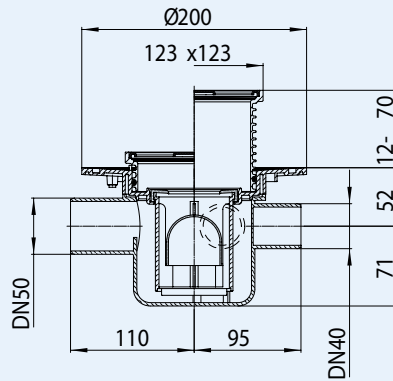

 HL037Pr.1E

 HL037N.0E

 HL037N.2E

 HL01067D

 HL0300.0EN

 HL0300.6E

 HL304K

HL-No. 304	Dimension DN50	Weight 795 g	EAN +703043	Piece/package 1
---------------	-------------------	-----------------	----------------	--------------------

HL310N Floor drain HL310N-3000 Floor drain like HL310N, but with stainless steel frame

Data

Capacity	0,75 l/s with 20 mm stowage height 0,55 l/s with 10 mm stowage height
Material	PP, stainless steel V2A
Outlet	DN50/75/110, vertical, pluggable
Extension	HL310N: 123 x 123 mm, cuttable in height HL310N-3000: 121 x 121 mm, „Klick-Klack-fixing system“, cuttable in height
Grate	Stainless steel grate 115 x 115 mm
Stench trap	Height of seal water 50 mm
Standard	EN 1253
Load classification	K 3 – max. 300 kg
Recommended for	Floor drainage with vertical connection
Additional information	temperature-resistant up to 85 °C
Including	Supporting frame, lot cover

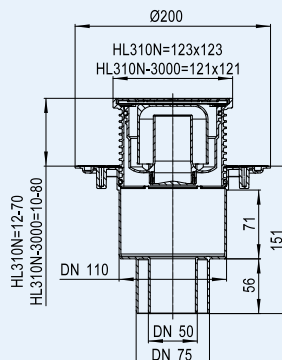

HL310N
HL310N-3000

 HL037Pr.1E

 HL037N.0E

 HL0510.7E

 HL0510.7EKK

 HL037N.2E

 HL3200

 HL01067D

 HL0300.0EN

 HL310K

HL-No. 310N 310N-3000	Dimension DN50/75/110 DN50/75/110	Weight 620 g 665 g	EAN +004638 +016327	Piece/package 1 1
-----------------------------	---	--------------------------	---------------------------	-------------------------

HL310N-3020 Floor drain with tilable extension
HL310Prblue-3020 like HL310N-3020, but with Primus **blue** trap

Data

Capacity	HL310N-3020 0,75 l/s with 20 mm stowage height 0,70 l/s with 10 mm stowage height HL310Prblue-3020 0,60 l/s with 20 mm stowage height 0,50 l/s with 10 mm stowage height
Material	PP,ABS, stainless steel V4A
Outlet	DN50/75/110, vertical, pluggable
Extension	132 x 132 mm with stainless steel frame V4A, cuttable in height
Grate	Stainless steel frame and special grate, to be filled with tiles Size of grate: 104 x 104 x 12 mm
Stench trap	HL310N-3020: Height of seal water 50mm HL310Prblue-3020: Primus blue trap with 50mm seal water
Standard	EN 1253, ÖNORM B2501
Load classification	K 3 - max. 300 kg
Recommended for	e.g. tiled showers, SPA-area
Additional information	Temperature-resistant up to 85°C
Including	Lot cover

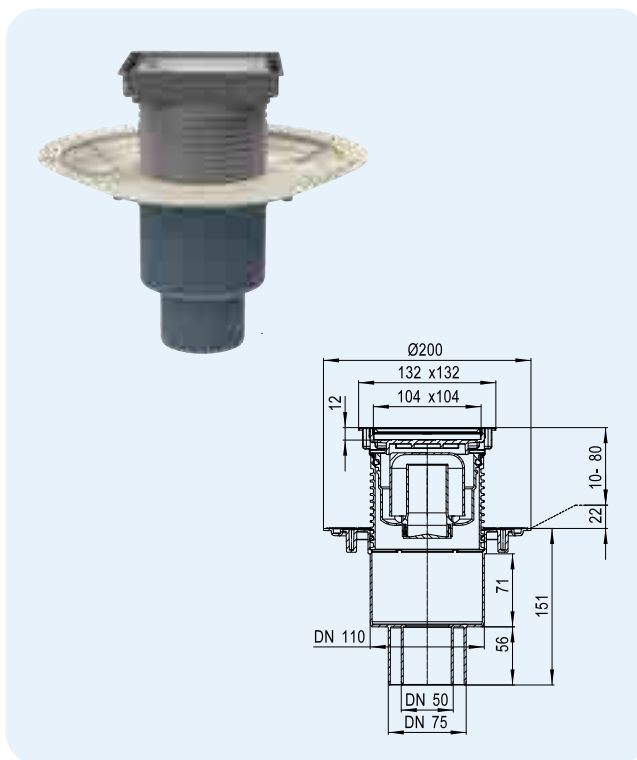

HL310N-3020 **HL310Prblue-3020**



HL-No.	Dimension	Weight	EAN	Piece/package
310N-3020	DN50/75/110	670 g	+034383	1
310Prblue-3020	DN50/75/110	727 g	+052011	1

HL310NG Floor drain with cast iron frame and grate
HL310NR Floor drain like HL310NG, but with round cover plate

Data

Capacity	HL310NG DN50: 0,85 l/s with 20 mm stowage height DN75 + DN110 0,75 l/s with 20 mm stowage height HL310NR 0,75 l/s with 20 mm stowage height 0,55 l/s with 10 mm stowage height
Material	cast iron/PP, stainless steel V2A
Outlet	DN50/75/110, vertical, pluggable
Extension	HL310NG: 150 x 150 mm, cuttable in height HL310NR: Ø 133 mm, cuttable in height
Grate	HL310NG: 137 x 137 mm, Cast iron HL310NR: Ø 112 mm, Stainless steel
Stench trap	Height of seal water 50 mm
Standard	EN 1253
Load classification	HL310NG: L15 – max. 1,5 t HL310NR: K 3 – max. 300 kg
Recommended for	HL310NG: e.g. carpark, mastic asphalt HL310NR: barrier-free showers
Additional information	temperature-resistant up to 85 °C
Including	Lot cover

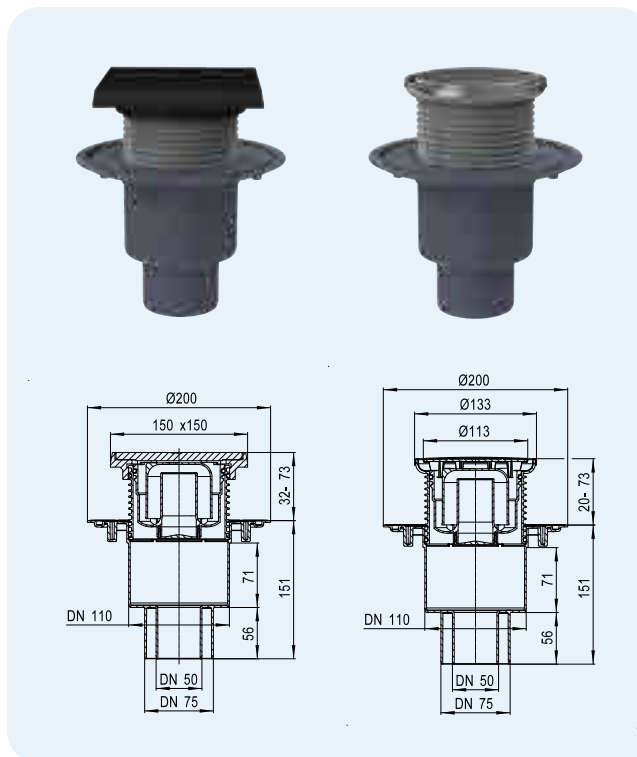

HL310NG **HL310NR**



HL-No.	Dimension	Weight	EAN	Piece/package
310NG	DN50/75/110	2295 g	+004652	1
310NR	DN50/75/110	560 g	+006038	1

HL310Prblue Floor drain with Primus **blue** trap
HL310Prblue-3000 like HL310Prblue, but with stainless steel frame

Data

Capacity	0,60 l/s with 20 mm stowage height 0,50 l/s with 10 mm stowage height
Material	PP
Outlet	DN50/75/110, vertical, pluggable
Extension	HL310Prblue: 123 x 123 mm, cuttable in height HL310Prblue-3000: 121 x 121 mm, „Klick-Klack-fixing system”, cuttable in height
Grate	Stainless steel grate 115 x 115 mm
Stench trap	Height of seal water 50 mm and Primus blue (No stench, with or without water)
Standard	EN 1253, ÖNORM B2501
Load classification	K 3 – max. 300 kg
Recommended for	Floor drainage with vertical connection
Additional information	Floor drainage especially at unrequent use, no stench with or without water, refilling of water into the trap is no longer necessary! Temperature resistant up to 85 °C
Including	Supporting frame, lot cover

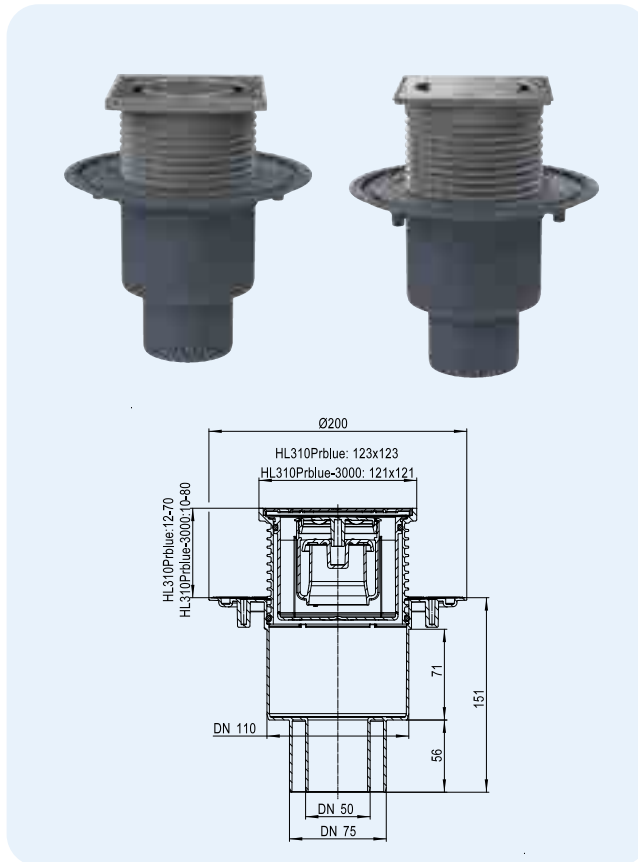

HL310Prblue
HL310Prblue-3000



HL-No.	Dimension	Weight	EAN	Piece/package
310Prblue	DN50/75/110	659 g	+051991	1
310Prblue-3000	DN50/75/110	722 g	+052004	1

HL310PrblueG Floor drain like HL310NG, but with Primus **blue** trap
HL310PrblueR Floor drain like HL310NR, but with Primus **blue** trap

Data

Capacity	HL310PrblueG 0,55 l/s with 20 mm stowage height HL310PrblueR 0,60 l/s with 20 mm stowage height 0,50 l/s with 10 mm stowage height
Material	cast iron/PP, stainless steel V2A
Outlet	DN50/75/110, vertical, pluggable
Extension	HL310PrblueG: 150 x 150 mm, cuttable in height HL310PrblueR: Ø 133 mm, cuttable in height
Grate	HL310PrblueG: 137 x 137 mm, Cast iron HL310PrblueR: Ø 112 mm, Stainless steel
Stench trap	Height of seal water 50 mm u. Primus blue (No stench, with or without water)
Standard	EN 1253, ÖNORM B2501
Load classification	HL310PrblueG: L15 – max. 1,5 t HL310PrblueR: K 3 – max. 300 kg
Recommended for	HL310PrblueG: e.g. car parks, mastic asphalt HL310PrblueR: barrier-free showers
Additional information	Floor drainage especially at unrequent use, no stench with or without water, refilling of water into the trap is no longer necessary! Temperature resistant up to 85° C
Including	Lot cover

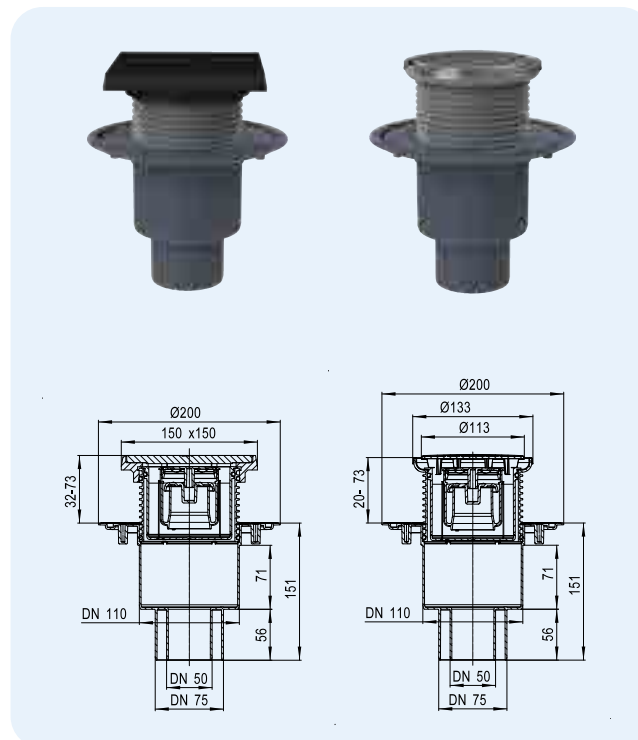

HL310PrblueG
HL310PrblueR



HL-No.	Dimension	Weight	EAN	Piece/package
310PrblueG	DN50/75/110	2324 g	+052073	1
310PrblueR	DN50/75/110	549 g	+052080	1

HL3100 Floor drain with high capacity

Data

Capacity	DN50: 1,25 l/s, DN75/110: 1,4 l/s
Material	PE, stainless steel
Outlet	DN50/75/110, vertical, pluggable and weldable
Extension	Stainless steel V4A, 145 x 145 mm, „Klick-Klack“-locking system, cuttable in height
Grate	Stainless steel V2A, 138 x 138 mm
Stench trap	Height of seal water 50 mm
Standard	EN 1253
Load classification	K 3 – max. 300 kg
Recommended for	Floor drain with high capacity, e.g. „Raindance“
Additional information	with „Klick-Klack-fixing system“, temperature-resistant up to 85 °C
Including	Supporting frame, lot cover

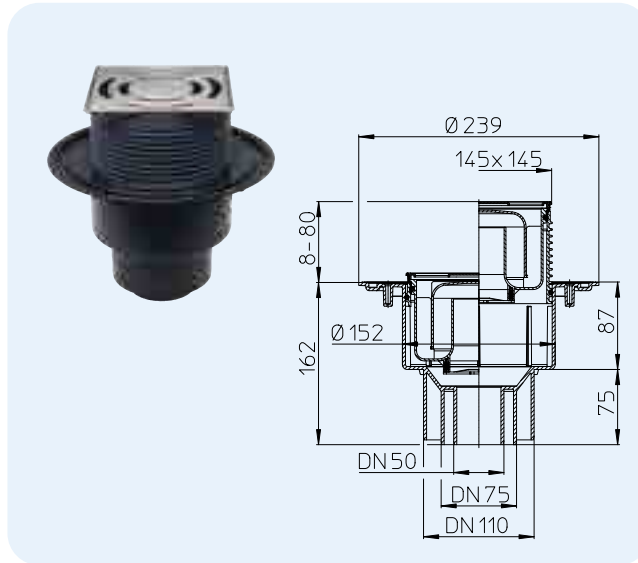

HL-No. 3100	Dimension DN50/75/110	Weight 1040 g	EAN +025428	Piece/package 1
----------------	--------------------------	------------------	----------------	--------------------

HL3100Pr Floor drain with high capacity and Primus trap

Data

Capacity	0,8 l/s
Material	PE, stainless steel
Outlet	DN50/75/110, vertical, pluggable and weldable
Extension	Stainless steel V4A, 145 x 145 mm, „Klick-Klack“-locking system, cuttable in height
Grate	Stainless steel V2A, 138 x 138 mm
Stench trap	Height of seal water 50 mm and Primus (No stench, with or without water)
Standard	EN 1253, ÖNORM B2501
Load classification	K 3 – max. 300 kg
Recommended for	Floor drain with high capacity, e.g. „Raindance“
Additional information	Floor drainage especially at unrequent use, no stench with or without water, refilling of water into the trap is no longer necessary! Temperature resistant up to 85 °C
Including	Supporting frame, lot cover

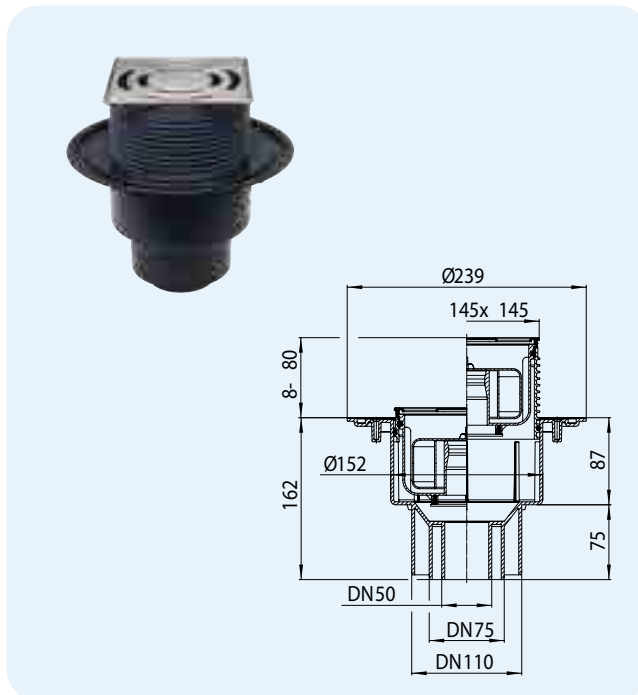

HL-No. 3100Pr	Dimension DN50/75/110	Weight 1079 g	EAN +025435	Piece/package 1
------------------	--------------------------	------------------	----------------	--------------------

HL317 Floor drain vertical

Data

Capacity	1,8 l/s
Material	PP, stainless steel V2A
Outlet	DN50/75/110, vertical, pluggable
Extension	150 x 150 mm, cuttable in height
Grate	Stainless steel grate 138 x 138 mm
Stench trap	Height of seal water 50 mm
Standard	EN 1253
Load classification	K 3 – max. 300 kg
Recommended for	Floor drain with high capacity
Additional information	temperature-resistant up to 95 °C
Including	Lot cover

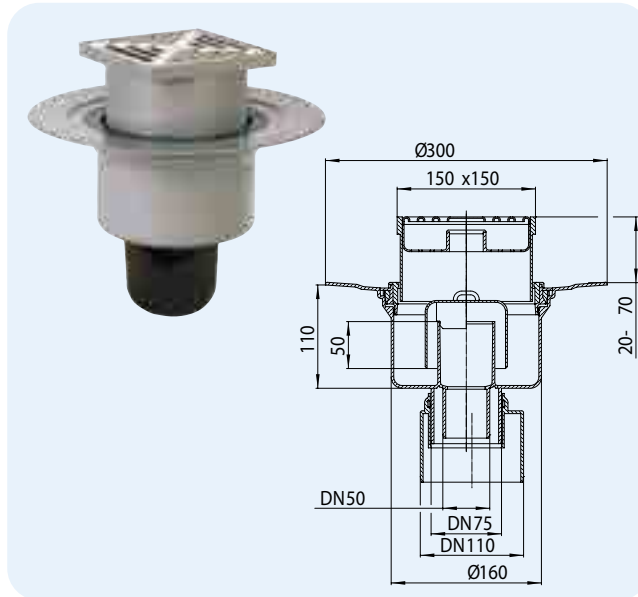

HL-No. 317	Dimension DN50/75/110	Weight 1200 g	EAN +703173	Piece/package 1
---------------	--------------------------	------------------	----------------	--------------------

HL317H Floor drain vertical with bitumen collar

Data

Capacity	1,8 l/s
Material	PP, stainless steel V2A
Outlet	DN50/75/110, vertical, pluggable
Extension	150 x 150 mm, cuttable in height
Grate	Stainless steel grate 138 x 138 mm
Stench trap	Height of seal water 50 mm
Standard	EN 1253
Load classification	K 3 – max. 300 kg
Recommended for	Floor drain with high capacity
Additional information	Bitumen waterproofings, temperature-resistant up to 95 °C
Including	Lot cover

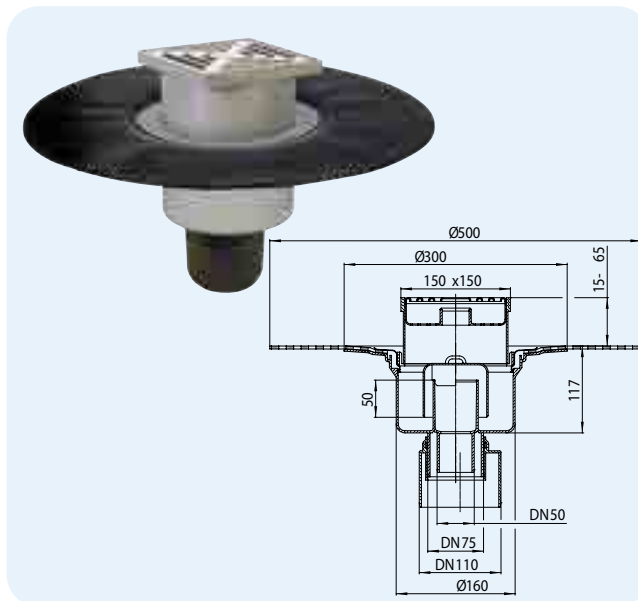

HL-No. 317H	Dimension DN50/75/110	Weight 1985 g	EAN +317110	Piece/package 1
----------------	--------------------------	------------------	----------------	--------------------

HL510N Floor drain

HL510N-3000 Floor drain like HL510N, but with stainless steel frame

Data

Capacity	0,55 l/s with 20 mm stowage height 0,45 l/s with 10 mm stowage height
Material	PP, stainless steel
Outlet	DN40/50, horizontal, pluggable
Extension	HL510N: 123 x 123 mm, cuttable in height HL510N-3000: 121 x 121 mm, „Klick-Klack-fixing system“, cuttable in height, stainless steel V4A
Grate	Stainless steel grate 115 x 115 mm, stainless steel V2A
Stench trap	Height of seal water 50 mm
Standard	EN 1253
Load classification	K 3 – max. 300 kg
Recommended for	Floor drainage with horizontal connection
Additional information	Sound protection acc. ÖNORM B8115-2 is reached together with HL6200 sound insulation pad (see chapter accessories). Temperature-resistant up to 85 °C
Including	Supporting frame, lot cover

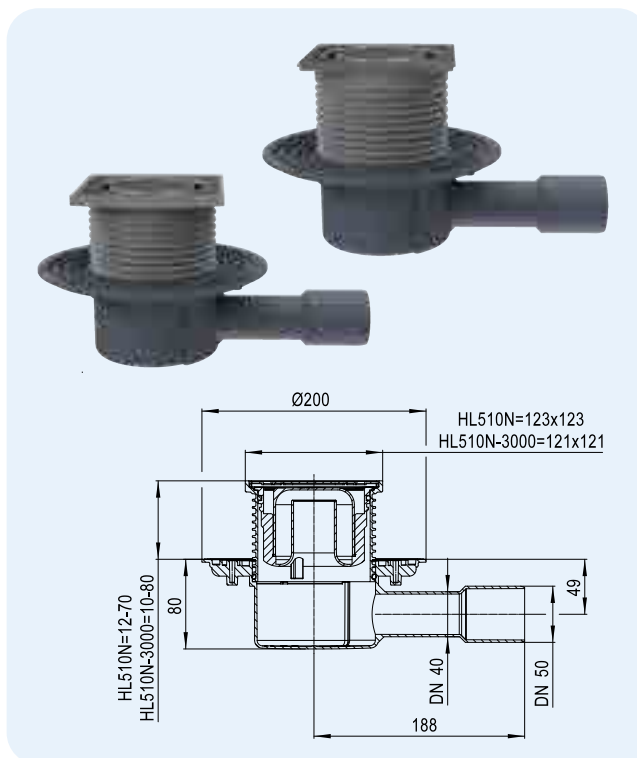

HL510N HL510N-3000



HL-No.	Dimension	Weight	EAN	Piece/package
510N	DN40/50	546 g	+051007	1
510N-3000	DN40/50	681 g	+016686	1

HL510N-3020 Floor drain with frame for tiles

HL510Prblue-3020 Like HL510N-3020, but with Primus blue trap

Data

Capacity	HL510N-3020: 0,55 l/s with 20 mm stowage height 0,45 l/s with 10 mm stowage height HL510Prblue-3020: 0,55 l/s with 20 mm stowage height 0,45 l/s with 10 mm stowage height
Material	PP, ABS, stainless steel V4A
Outlet	DN40/50, horizontal, pluggable
Extension	132 x 132 mm with stainless steel frame V4A, cuttable in height
Grate	Stainless steel frame and special grate, to be filled with tiles Size of grate: 104 x 104 x 12 mm
Stench trap	HL510N-3020: Height of seal water 50 mm HL510Prblue-3020: Primus blue trap with 50mm seal water
Standard	EN 1253, ÖNORM B2501
Load classification	K 3 - max. 300 kg
Recommended for	e.g. tiled showers, SPA-area
Additional information	Sound protection acc. ÖNORM B8115-2 is reached together with HL6200 sound insulation pad (see chapter accessories). Temperature-resistant up to 85 °C
Including	Lot cover

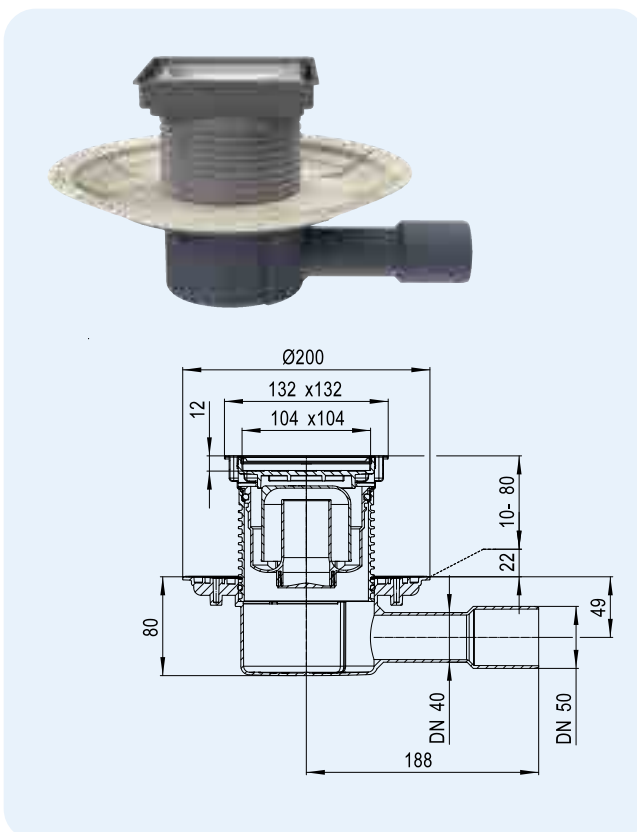

HL510N-3020 HL510Prblue-3020



HL-No.	Dimension	Weight	EAN	Piece/package
510N-3020	DN40/50	686 g	+034406	1
510Prblue-3020	DN40/50	738 g	+052110	1

HL510NG Floor drain with cast iron frame and grate
HL510NR like HL510NG, but with round stainless steel cover plate

Data

Capacity	HL510NG 0,60 l/s with 20 mm stowage height HL510NR 0,55 l/s with 20 mm stowage height 0,45 l/s with 10 mm stowage height
Material	cast iron/PP, stainless steel V2A
Outlet	DN40/50, horizontal, pluggable
Extension	HL510NG: 150 x 150 mm, cuttable in height HL510NR: Ø 133 mm, cuttable in height
Grate	HL510NG: 137 x 137 mm, Cast ironrost HL510NR: Ø 112 mm Edelstahl
Stench trap	Height of seal water 50 mm
Standard	EN 1253
Load classification	HL510NG: L15 – max. 1,5 t HL510NR: K 3 – max. 300 kg
Recommended for	HL510NG: e.g. carpark, mastic asphalt HL510NR: barrier-free showers
Additional information	Temperature-resistant up to 85 °C
Including	Lot cover

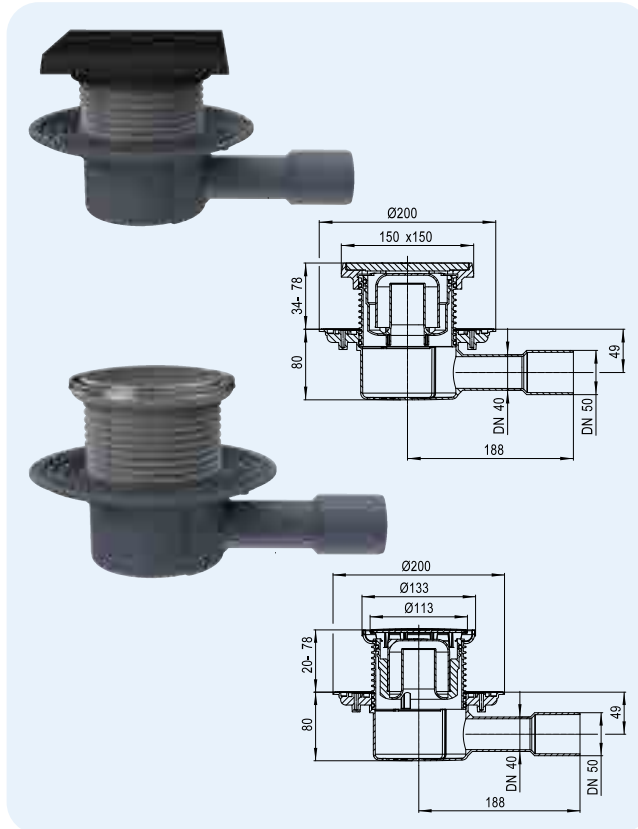

HL510NG **HL510NR**



HL-No.	Dimension	Weight	EAN	Piece/package
510NG	DN40/50	2221 g	+001965	1
510NR	DN40/50	546 g	+006076	1

HL510Prblue Floor drain with Primus **blue** trap
HL510Prblue-3000 like HL510Prblue, but with stainless steel frame

Data

Capacity	0,50 l/s with 20 mm stowage height 0,40 l/s with 10 mm stowage height
Material	PP, stainless steel
Outlet	DN40/50, horizontal, pluggable
Extension	HL510Prblue: 123 x 123 mm, cuttable in height HL510Prblue-3000: 121 x 121 mm, „Klick-Klack-fixing system“, cuttable in height, stainless steel V4A
Grate	Stainless steel grate 115 x 115 mm, stainless steel V2A
Stench trap	Height of seal water 50 mm and Primus blue (No stench, with or without water)
Standard	EN 1253, ÖNORM B2501
Load classification	K 3 – max. 300 kg
Recommended for	Floor drainage with horizontal connection
Additional information	Floor drainage especially at unrequent use, no stench with or without water, refilling of water into the trap is no longer necessary! Sound protection acc. ÖNORM B8115-2 is reached together with HL6200 sound insulation pad (see chapter accessories). Temperature-resistant up to 85 °C
Including	Supporting frame, lot cover

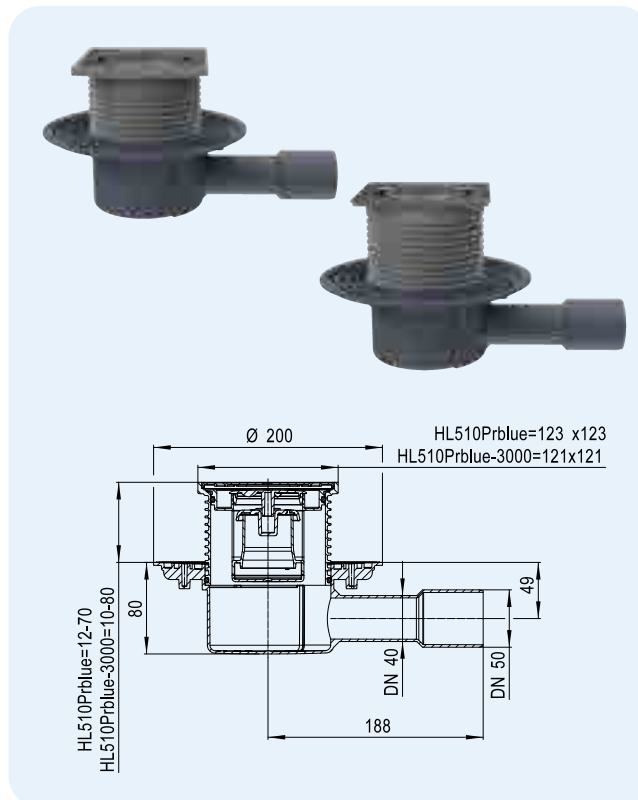

HL510Prblue
HL510Prblue-3000



HL-No.	Dimension	Weight	EAN	Piece/package
510Prblue	DN40/50	675 g	+052097	1
510Prblue-3000	DN40/50	732 g	+052103	1

HL510PrblueG Floor drain with Primus **blue** odor barrier, cast frame and grate
HL510PrblueR like HL510PrblueG, but with round stainless steel cover

Data

Capacity	HL510PrblueG 0,55 l/s with 20 mm stowage height HL510PrblueR 0,50 l/s with 20 mm stowage height 0,40 l/s with 10 mm stowage height
Material	cast iron/PP, stainless steel V2A
Outlet	DN40/50, horizontal, pluggable
Extension	HL510PrblueG: 150 x 150 mm, cuttable in height HL510PrblueR: Ø 133 mm, cuttable in height
Grate	HL510PrblueG: 137 x 137 mm, cuttable in height HL510PrblueR: Ø 112 mm, cuttable in height
Stench trap	Height of seal water 50 mm and Primus blue (No stench, with or without water)
Standard	EN 1253, ÖNORM B2501
Load classification	HL510PrblueG: L15 – max. 1,5 t HL510PrblueR: K 3 – max. 300 kg
Recommended for	HL510PrblueG: e.g. carparks, mastic asphalt HL510PrblueR: barrier-free showers
Additional information	Floor drainage especially at unrequent use, no stench with or without water, refilling of water into the trap is no longer necessary! Sound protection acc. ÖNORM B8115-2 is reached together with HL6200 sound insulation pad (see chapter accessories). Temperature-resistant up to 85 °C
Including	Lot cover

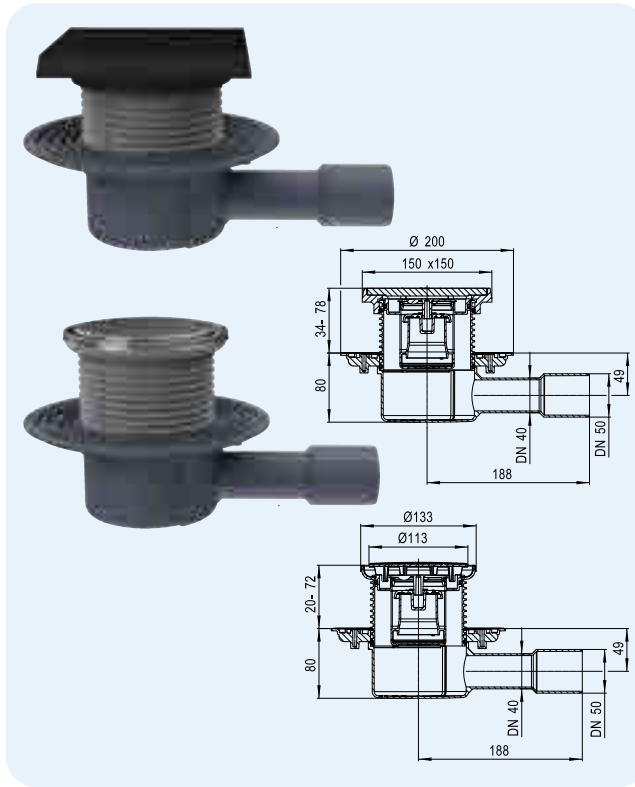

HL-No.	Dimension	Weight	EAN
510PrblueG	DN40/50	2425 g	+052172
510PrblueR	DN40/50	675 g	+052189

HL510PrblueG
HL510PrblueR



Piece/package
1
1

HL90Prblue Floor drain flat with Primus **blue** trap
HL90Prblue-3000 like HL90Prblue, but with stainless steel frame

Data

Capacity	0,45 l/s with 20 mm stowage height 0,4 l/s with 10 mm stowage height
Material	PP, stainless steel V2A
Outlet	DN40/50, horizontal, pluggable
Extension	HL90Prblue: 123 x 123 mm, cuttable in height HL90Prblue-3000: 121 x 121 mm, „Klick-Klack-fixing system“, cuttable in height, stainless steel V4A
Grate	Stainless steel grate 115 x 115 mm, stainless steel V2A
Odor trap	New Primus blue , combined odor trap with sealing water and mechanical odor barrier (absolutely odor-tight even without water). Backflow-proof up to 50 cm accumulation height
Standard	EN 1253, ÖNORM B2501
Load classification	K 3 – max. 300 kg
Recommended for	Floor constructions < 100 mm
Additional information	Floor drainage especially at unrequent use, no stench with or without water, refilling of water into the trap is no longer necessary! Sound protection acc. ÖNORM B8115-2 is reached together with HL6200 sound insulation pad (see chapter accessories). Hair catcher HL0541.6E available as accessories! Temperature-resistant up to 85 °C
Including	Supporting frame, lot cover

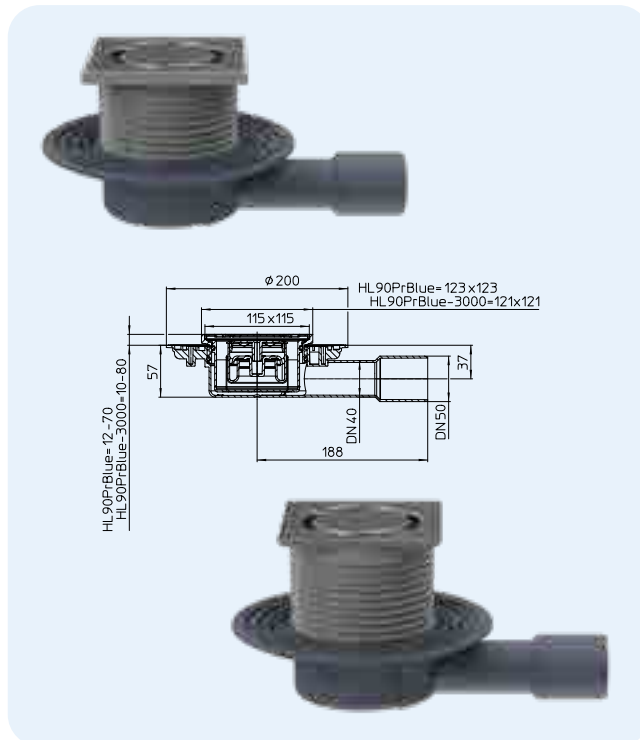

HL-No.	Dimension	Weight	EAN
90Prblue	DN40/50	510 g	+050505
90Prblue-3000	DN40/50	564 g	+050512

HL90Prblue
HL90Prblue-3000



Piece/package
1
1

HL90Prblue-3020 Floor drain with tilable extension and PRIMUS trap

Data

Capacity	0,5 l/s with 20 mm stowage height 0,45 l/s with 10 mm stowage height
Material	PP, ABS, stainless steel V4A
Outlet	DN40/50, horizontal, pluggable
Extension	132 x 132 mm with stainless steel frame V4A, cuttable in height
Grate	Stainless steel frame and special grate, to be filled with tiles Size of grate: 104 x 104 x 12 mm
Odor trap	New Primus blue , combined odor trap with sealing water and mechanical odor barrier (absolutely odor-tight even without water). Backflow-proof up to 50 cm accumulation height
Standard	EN 1253, ÖNORM B2501
Load classification	K 3 - max. 300 kg
Recommended for	e.g. tiled showers, SPA-area, with floor levels < 100mm
Additional information	Sound protection acc. ÖNORM B8115-2 is reached together with HL6200 sound insulation pad (see chapter accessories) Hair catcher HL0541.6E available as accessories! Temperature-resistant up to 85 °C
Including	Lot cover

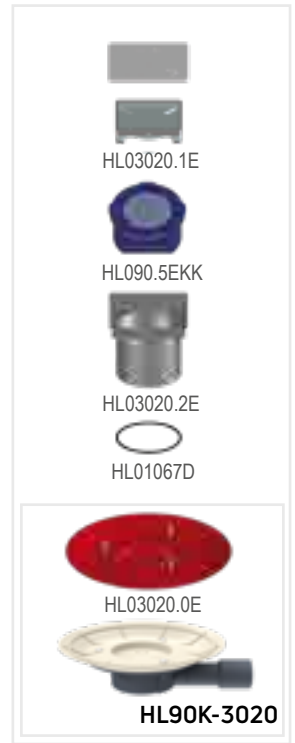
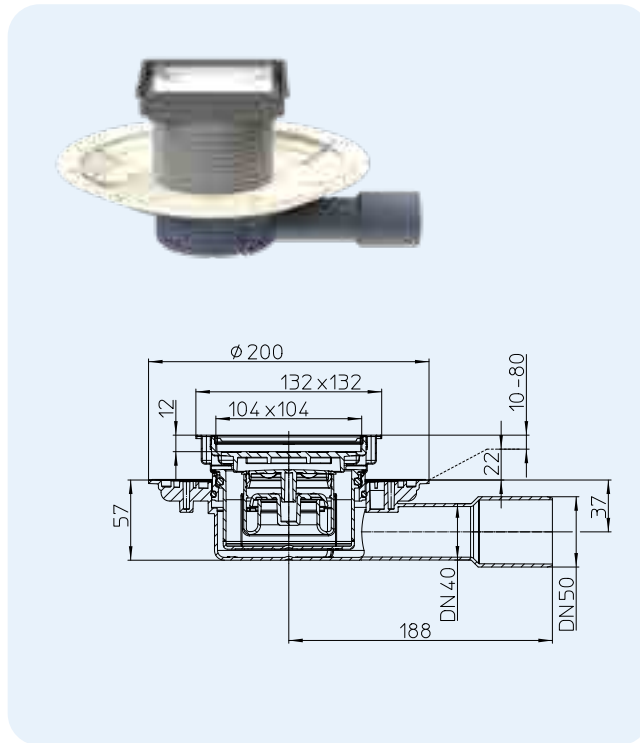

HL-No.	Dimension	Weight	EAN	Piece/package
90Prblue-3020	DN40/50	570 g	+050529	1

HL90PrblueD Floor drain with integrated fleece flange HL90PrblueD-3000 like HL90PrblueD, but with stainless steel frame

Data

Capacity	0,45 l/s with 20 mm stowage height 0,40 l/s with 10 mm stowage height
Material	PP/PE, stainless steel
Outlet	DN40, horizontal, pluggable and weldable
Extension	HL90PrblueD: 123 x 123 mm, cuttable in height HL90PrblueD-3000: 121 x 121 mm, „Klick-Klack-fixing system“, cuttable in height, stainless steel V4A
Grate	Stainless steel grate 115 x 115 mm, stainless steel V2A
Odor trap	New Primus blue , combined odor trap with sealing water and mechanical odor barrier (absolutely odor-tight even without water). Backflow-proof up to 50 cm accumulation height
Standard	EN 1253, ÖNORM B2501
Load classification	K 3 – max. 300 kg
Recommended for	Floor constructions < 100 mm
Additional information	Floor drainage especially at uninfrequent use, no stench with or without water, refilling of water into the trap is no longer necessary! Sound protection acc. ÖNORM B8115-2 is reached together with HL6200 sound insulation pad (see chapter accessories). Hair catcher HL0541.6E available as accessories! Temperature-resistant up to 85 °C
Including	Supporting frame, lot cover

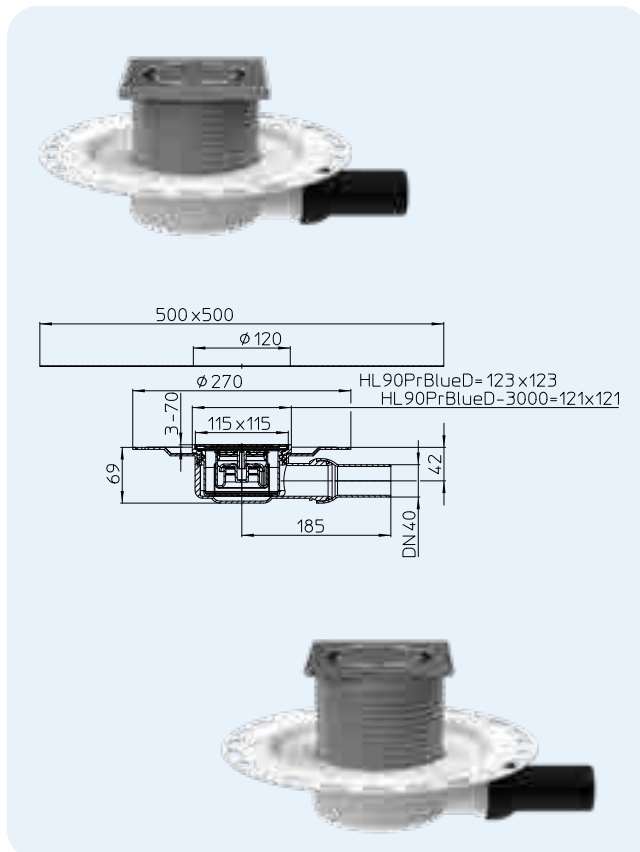

HL-No.	Dimension	Weight	EAN	Piece/package
90PrblueD	DN40	812 g	+050543	1
90PrblueD-3000	DN40	855 g	+050550	1

HL540 „Primus Drain“ Shower drain, MIN. HEIGHT 80 MM !

HL540I „Primus Drain“ Shower drain with individual tile hollow, MIN. HEIGHT 80 MM !

Data

Capacity 20 mm above drain level:
HL540=0,8l/s; HL540i=0,6/s
10 mm above drain level:
HL540=0,55l/s; HL540i=0,45l/s

Material PP/stainless steel, Frame: V4A
Grate HL540=V2A
Grate HL540i=V4A

Outlet DN50 horizontal

Height from 8 - 20 cm adjustable

Standard EN 1253

Stench trap 5cm seal water, incl. Primus-trap, no stench without seal water

Additional information incl. removable trap inlet, sealing kit with textile coated membrane, sound disconnected adjusting angles, protection cover and lot cover
Soundproofing tested
Test certificate: www.hl.at

Installation The drain body might be fixed on the floor with 3 metal angles and can be adjusted in height afterwards. Advantage: maximum speed covering of the outlet pipe. New: It is no longer necessary to set the drain exactly on the right height of the screed. After filling in the screed, the salient nozzle is cut by a saw. The sealing kit may be inserted without any tools and takes care of a safe connection to the waterproofing. At the end the extension is adjusted and set into the drain. Please take care, that the edges of the frame are underlaid with tile glue to take maximum load.

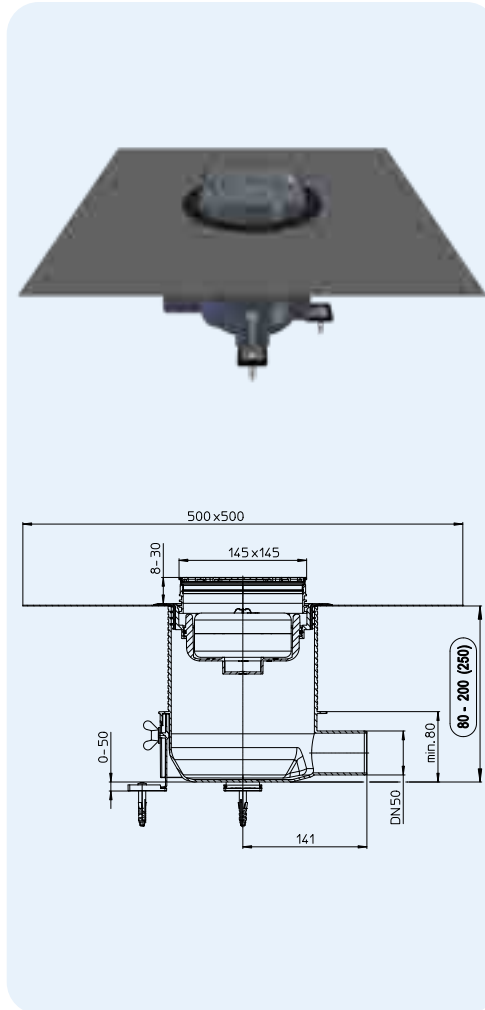

Please also see installation movie at www.hl.at

HL-No.	Material	Dimension	Weight	EAN	Piece/package
540	PP/Stainless steel	DN50	1533 g	+039029	1
540I	PP/Stainless steel	DN50	1898 g	+039098	1
540-Quadra	PP/Stainless steel	DN50	1898 g	+041817	1
540-Cut	PP/Stainless steel	DN50	1898 g	+041800	1
540-Hamam	PP/Stainless steel/ PVD-coated	DN50	1898 g	+041824	1

HL066Q.1E, HL066C.1E, HL0540I, HL3928, HL3128E Design grates

Data

Material Stainless steel

Grate HL540I: 138x138mm massive, Tile hollow: 74x74 mm, depth 13mm

Load classification L - max. 1,5t, HL0540I - K3

Recommended for Shower drain HL540 or floor drain series HL5100, HL3100, HL72.1 and HL317

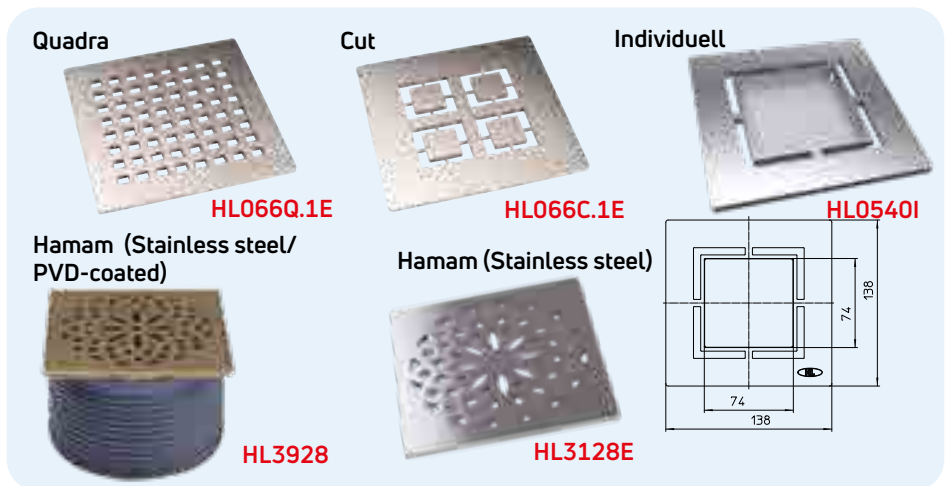

HL-No.	Material	Dimension	Weight	EAN	Piece/package
066Q.1E	Stainless steel V2A	138 x 138 x 5 mm	607 g	+013623	1
066C.1E	Stainless steel V2A	138 x 138 x 5 mm	608 g	+031283	1
0540I	Stainless steel V4A	138 x 138 x 5 mm	638 g	+039104	1
3928	Stainless steel V4A/V2A/PVD-coated	138 x 138 x 5 mm	608 g	+031283	1
3128E	Stainless steel V2A	138 x 138 x 5 mm	595 g	+037094	1

HL541 Primus blue Flat shower drain, MIN. HEIGHT 62MM!

HL541I Primus blue Flat shower drain with individual tile hollow, MIN. HEIGHT 62MM!

Data

Capacity	20 mm above drain level: HL541=0,5l/s; HL541i=0,45/s 10 mm above drain level: HL541=0,4l/s; HL541i=0,4l/s
Material	PP/stainless steel, Frame: V4A Grate HL541=V2A Grate HL541i=V4A
Outlet	DN40/DN50 horizontal
Height	from 62 - 200 (230) mm
Standard	EN 1253
Load classification	K3 - max. 300 kg
Odor trap	New Primus blue , combined odor trap with sealing water and mechanical odor barrier (absolutely odor-tight even without water). Backflow-proof up to 50 cm accumulation height
Additional information	Incl. removable trap inlet, sealing kit with fleece laminated mem- brane, adjustable fixing angles, hair catcher, lot cover and protection cover.
Installation	The drain body might be fixed on the floor with 3 metal angles and can be adjusted in height afterwards. Advantage: maximum speed covering of the outlet pipe. New: It is no longer necessary to set the drain exactly on the right height of the screed. After filling in the screed, the salient nozzle is cut by a saw. The sealing kit may be inserted without any tools and takes care of a safe connection to the waterproofing. At the end the extension is adjusted and set into the drain. Please take care, that the edges of the frame are underlaid with tile glue to take maximum load.

Please also see
installation movie and
movie „function of
Primus blue“
at www.hl.at

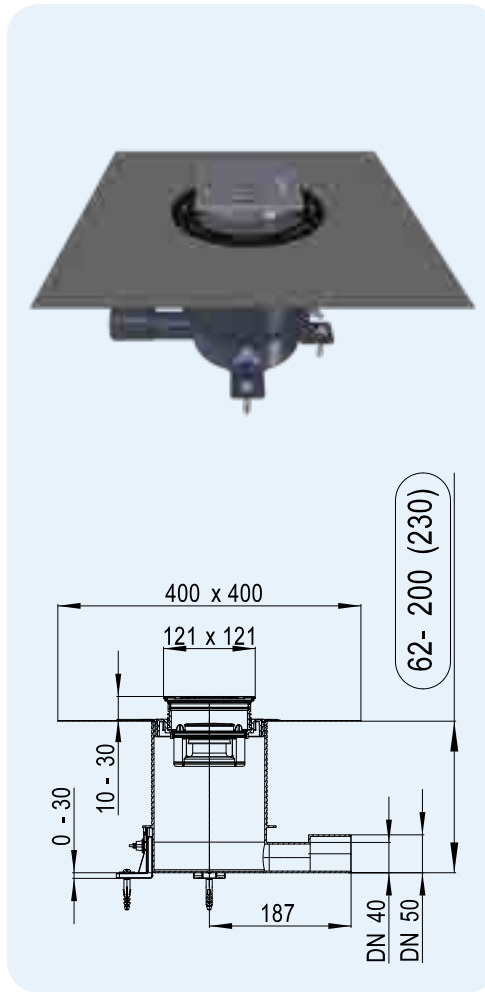

HL-No.	Material	Dimension	Weight	EAN	Piece/package
541	PP/Stainless steel	DN40/50	-	+047642	1
541I	PP/Stainless steel	DN40/50	-	+047659	1
541-Quadra	PP/Stainless steel	DN40/50	-	-	1

HL0541I, HL3120, HL3121, HL3122, HL3123, HL3124, HL3125, HL3127 Design grates

Daten

Material	Stainless steel V4A
Grate	Stainless steel grate 115 x 115 mm
Load classification	L – max. 1,5 t
Recommended for	Floor drain series HL70, HL80, HL300, HL304, HL310, HL510, HL90 combined with extensions HL3200 or HL3210 HL0541I: HL541

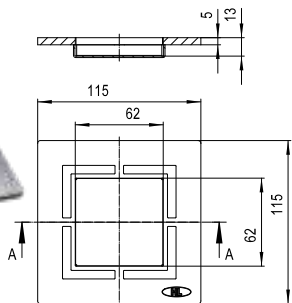
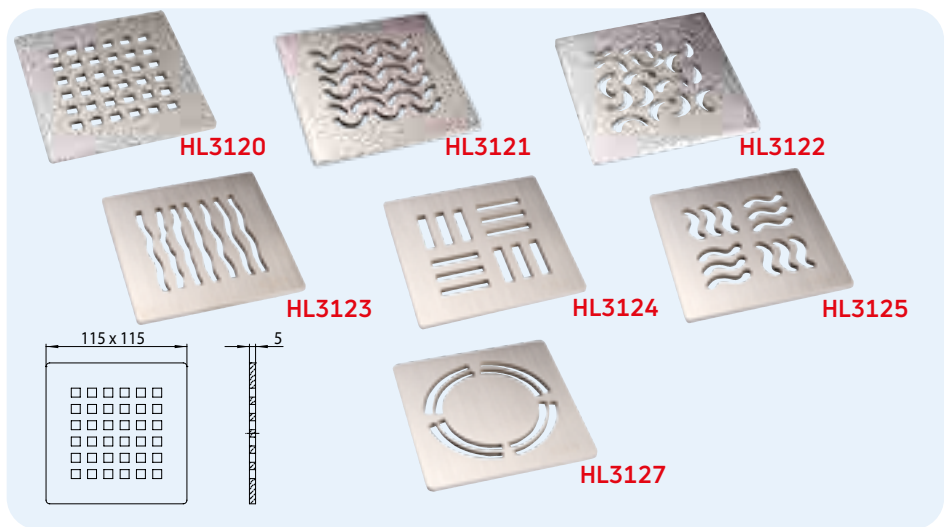

HL-No.	Dimension	Weight	EAN	Piece/package
3120	115 x 115 mm	425 g	+015412	1
3121	115 x 115 mm	425 g	+015429	1
3122	115 x 115 mm	425 g	+015443	1
3123	115 x 115 mm	425 g	+015443	1
3124	115 x 115 mm	425 g	+015450	1
3125	115 x 115 mm	425 g	+015467	1
3127	115 x 115 mm	430 g	+029037	1
0541I	115 x 115 mm	800 g	+048304	1

HL542Prblue Shower drain for coated floor coverings
HL542Prblue.0 Floor drain, without waterproofing fleece

Data

Capacity	0,4 l/s
Material	PP, Stainless steel V4A
Outlet dimension	DN40/50 horizontal
Constr. height	63 - 200 mm (230 mm)
Standard	EN 1253
Load class	K3 - max. 300 kg
Odour barrier	Primus blue, hybrid trap, combining a mechanical trap and a classical water trap (absolute odour proof even without water). Backflow resistant up to a pressure of 0,5 mWs
Additional Information	incl. Removable trap inlet, adjustable fixing angles, hair catcher, lot cover and protection cover
Installation	HL542Prblue Liquid shower and floor drain for coated floor coverings, with adjustable stainless-steel frame (from 1 to 7 mm) for adaption to the final surface height. Sealing set with fleece covered foil (HL542Prblue) to apply the waterproofing and a stainless steel flange for a secure connection to the floor coating material. Incl. Primus blue trap, Combined cover, extension rings and protection cover. Please also see installation movie and the function of Primus blue at www.hl.at

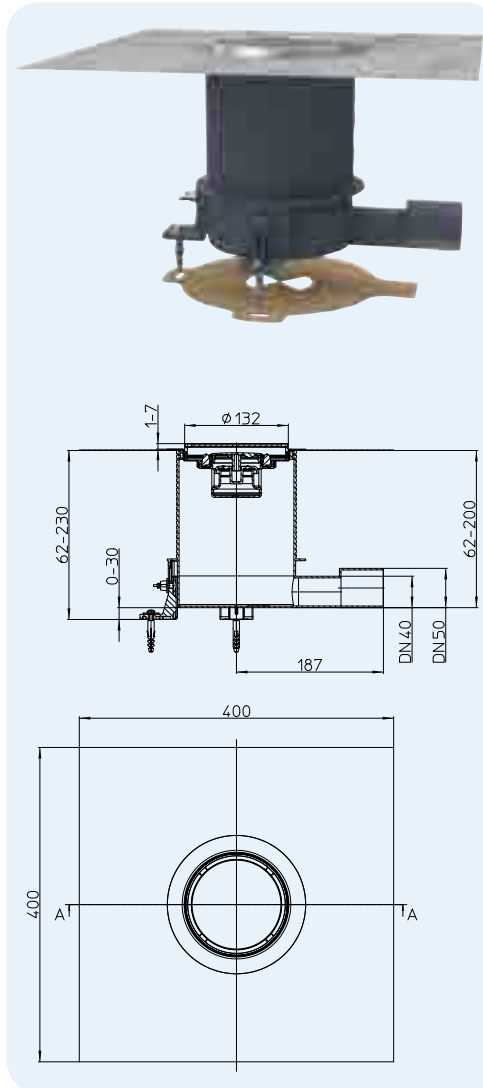

HL542Prblue

HL542Prblue.0



HL0542.4E



HL0542.6E

HL541K



HL-Nr.	Dimension	Cover	Weight	EAN	Pcs / package
542Prblue	DN40/50	Stainless steel V4A	1313 g	+050154	1
542Prblue.0	DN40/50	Stainless steel V4A	1238 g	+052622	1

HL5100 Floor drain with high capacity

Data

Capacity	1,0 l/s
Material	PE, stainless steel
Outlet	DN50/75 horizontal, pluggable and weldable
Extension	Stainless steel V4A, 145 x 145 mm, „Klick-Klack“-locking system, cuttable in height
Grate	Stainless steel V2A, 138 x 138 mm
Stench trap	Height of seal water 50 mm
Standard	EN 1253
Load classification	K 3 – max. 300 kg
Recommended for	e.g. barrier-free showers with high volume (Raindance)
Additional information	with stainless steel frame, Sound protection acc. ÖNORM B8115-2 is reached together with HL6200 sound insulation pad (see chapter accessories). Temperature-resistant up to 85 °C
Including	Supporting frame, lot cover

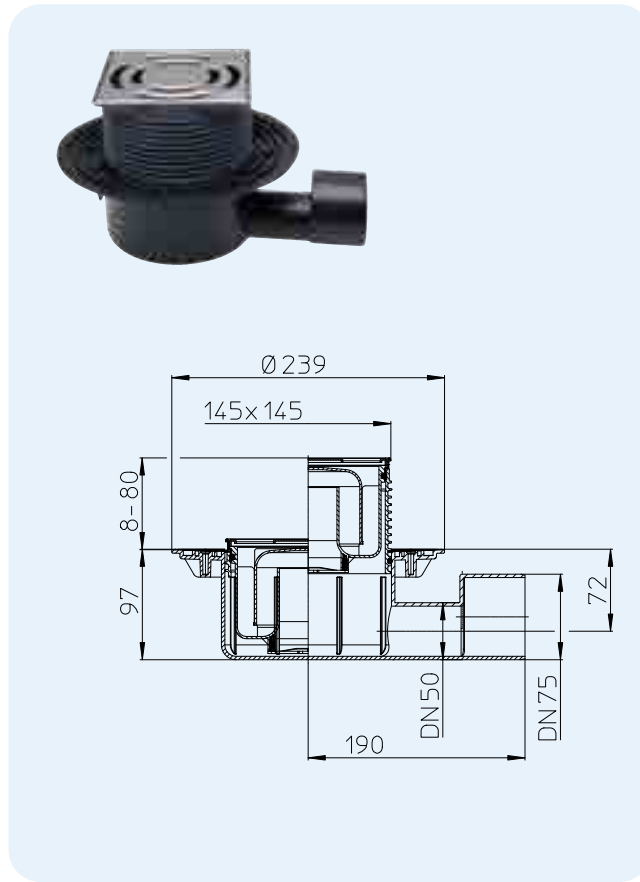

HL-No. 5100	Dimension DN50/75	Weight 1025 g	EAN +025442	Piece/package 1
----------------	----------------------	------------------	----------------	--------------------

HL5100Pr Floor drain with high capacity, with PRIMUS trap

Data

Capacity	0,8 l/s
Material	PE, stainless steel
Outlet	DN50/75 horizontal, pluggable and weldable
Extension	Stainless steel V4A, 145 x 145 mm, „Klick-Klack“-locking system, cuttable in height
Grate	Stainless steel V2A, 138 x 138 mm
Stench trap	Height of seal water 50 mm and PRIMUS (No stench, with or without water)
Standard	EN 1253, ÖNORM B2501
Load classification	K 3 – max. 300 kg
Recommended for	e.g. barrier-free showers with high volume (Raindance)
Additional information	with stainless steel frame, Floor drainage especially at uninfrequent use, no stench with or without water, refilling of water into the trap is no longer necessary! Sound protection acc. ÖNORM B8115-2 is reached together with HL6200 sound insulation pad (see chapter accessories). Temperature-resistant up to 85 °C
Including	Supporting frame, lot cover

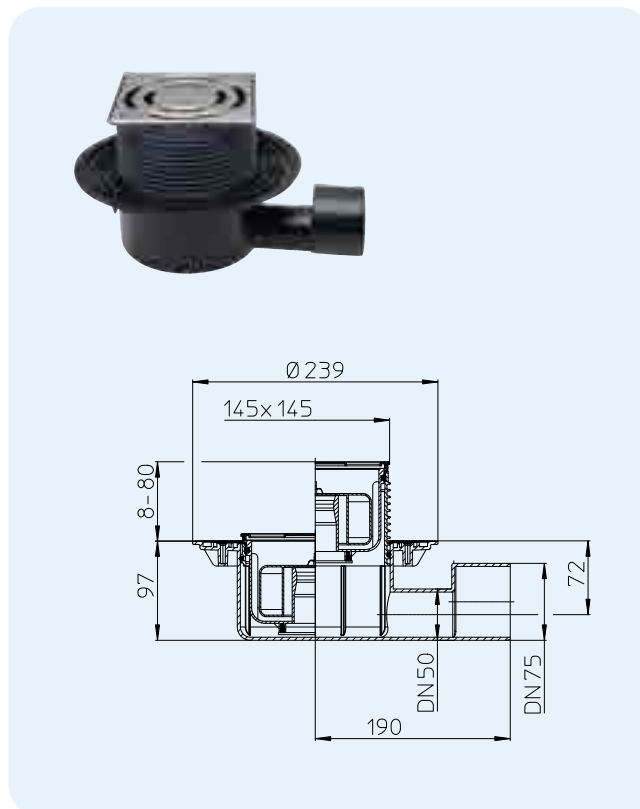

HL-No. 5100Pr	Dimension DN50/75	Weight 1069 g	EAN +025459	Piece/package 1
------------------	----------------------	------------------	----------------	--------------------

HL72.1N Floor drain
HL72.1 like HL72.1, but with plastic grate

Data	
Capacity	1,5 l/s
Material	PP, stainless steel V2A
Outlet	DN75/110 horizontal, pluggable
Extension	150 x 150 mm, cuttable in height
Grate	HL72.1: Plastic grate 138 x 138 mm, HL72.1N: Stainless steel grate 138 x 138 mm
Stench trap	Height of seal water 60 mm
Standard	EN 1253
Load classification	K 3 – max. 300 kg
Recommended for	e.g. barrier-free showers with high volume (Raindance)
Additional information	temperature-resistant up to 95 °C
Including	Lot cover and Sand trap

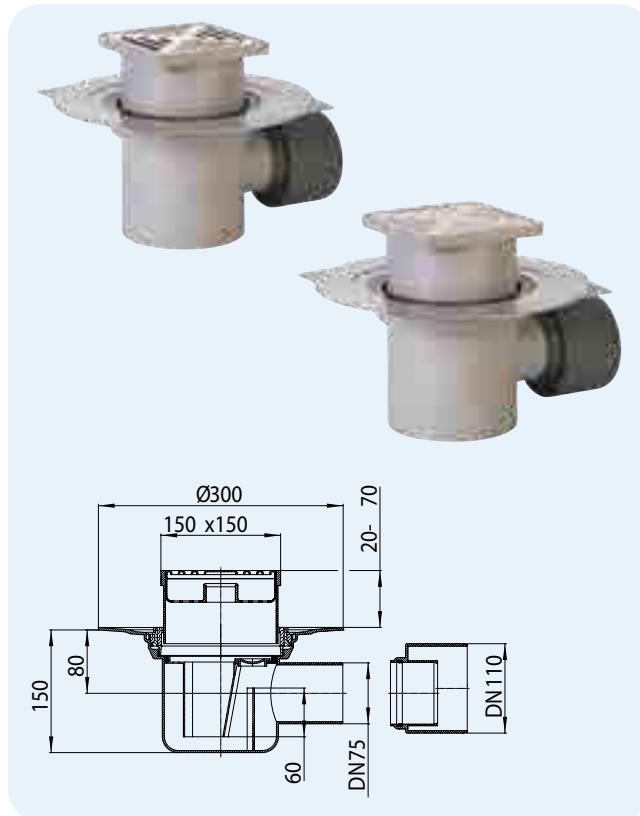

HL-No.	Dimension	Weight	EAN	Piece/package
72.1N	DN75/100	1330 g	+107216	1
72.1	DN75/100	1330 g	+710720	1

HL72.1HN Floor drain with bitumen collar
HL72.1H Floor drain with bitumen collar and plastic grate

Data	
Capacity	1,5 l/s
Material	PP, stainless steel V2A
Outlet	DN75/110 horizontal, pluggable
Extension	150 x 150 mm, cuttable in height
Grate	HL72.1H: Plastic grate 138 x 138 mm, HL72.1HN: Stainless steel grate 138 x 138 mm
Stench trap	Height of seal water 60 mm
Standard	EN 1253
Load classification	K 3 – max. 300 kg
Recommended for	e.g. barrier-free showers with high volume (Raindance)
Additional information	temperature-resistant up to 95 °C
Including	Lot cover and Sand trap

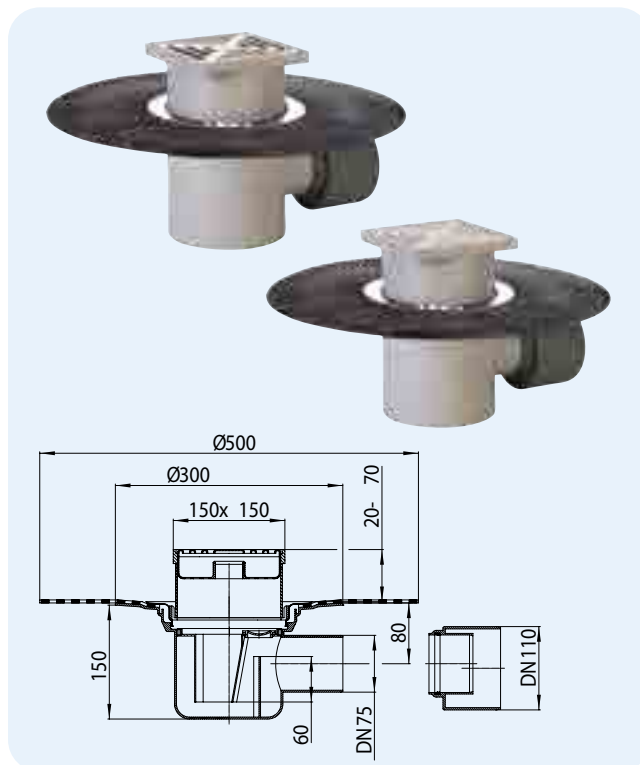

HL-No.	Dimension	Weight	EAN	Piece/package
72.1HN	DN75/100	2200 g	+072118	1
72.1H	DN75/100	2086 g	+997213	1

HL Floor drains – Accessories – Data

HL37N Standard extension

Data

Material	PP, stainless steel V2A
Extension	PP-Frame 123 x 123 mm, extension cuttable in height
Grate	Stainless steel grate 115 x 115 mm
Load classification	K 3 – max. 300 kg
Recommended for	Drain bodies of series HL70, HL80, HL300, HL304, HL310, HL510, HL90
Including	Supporting frame

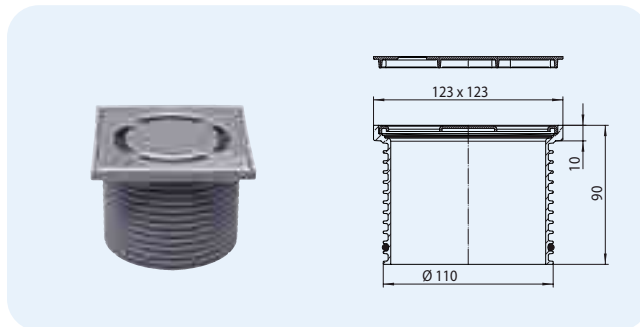

HL-No.	Dimension	Weight	EAN	Piece/package
37N	Ø 110 mm / 123 x 123 mm	350 g	+015221	1

HL37N.1 Extension with water trap HL37Prblue Extension with Primus blue trap HL37FPblue Extension with flat Primus blue trap

Data

Material	PP, stainless steel V2A
Extension	PP-Frame 123 x 123 mm, extension cuttable in height
Grate	Stainless steel grate 115 x 115 mm
Stench trap	HL37N.1: Water trap HL37Prblue: Primus blue trap HL37FPblue: Primus blue trap „flat“
Load classification	K 3 – max. 300 kg
Recommended for	Drain bodies of series HL310 and HL510
Including	Supporting frame

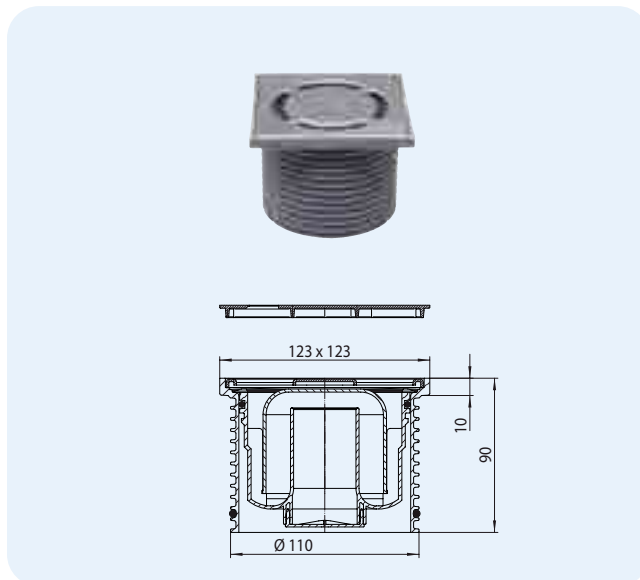

HL-No.	Dimension	Weight	EAN	Piece/package
37N.1	Ø 110 mm / 123 x 123 mm	380 g	+015245	1
37Prblue	Ø 110 mm / 123 x 123 mm	434 g	+051960	1
37FPblue	Ø 110 mm / 123 x 123 mm	402 g	+050536	1

HL3000 Extension system „Klick-Klack“ with stainless steel frame HL3011 Extension system „Klick-Klack“ with stainless steel frame, screwed

Data

Material	PE, stainless steel
Extension	Stainless steel frame 121 x 121 mm, extension cuttable in height, stainless steel V4A
Grate	Stainless steel grate 115 x 115 mm, stainless steel V2A
Load classification	K 3 – max. 300 kg
Recommended for	Drain bodies of series HL70, HL80, HL300, HL304, HL310, HL510, HL90
Including	Supporting frame

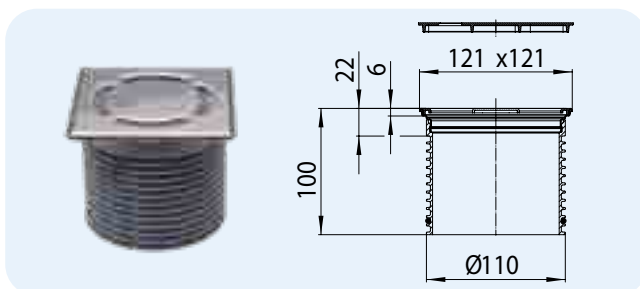

HL-No.	Dimension	Weight	EAN	Piece/package
3000	Ø 110 mm / 121 x 121 mm	340 g	+015313	1
3011	Ø 110 mm / 121 x 121 mm	340 g	+032624	1

HL3000.1 Extension „Klick-Klack“, including water trap
HL3000Prblue Extension „Klick-Klack“, including Primus **blue** trap
HL3000FPblue Extension, including Primus **blue** trap - flat

Data

Material	PE, stainless steel
Extension	Stainless steel frame 121 x 121 mm, extension cuttable in height, stainless steel V4A
Grate	Stainless steel grate 115 x 115 mm, stainless steel V2A
Stench trap	HL3000.1: Water trap HL3000Prblue: Primus blue trap HL3000FPblue: Primus blue trap „flat“
Load classification	K 3 – max. 300 kg
Recommended for	Drain bodies of series HL310 and HL510
Including	Supporting frame

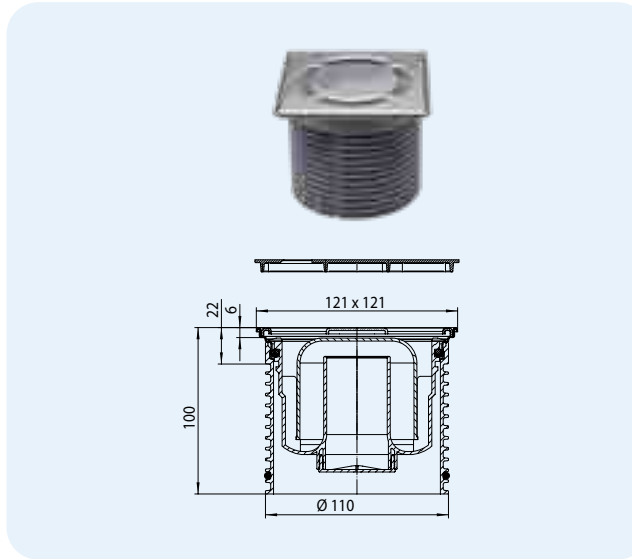
HL3000.1 HL3000Prblue HL3000FPblue

HL3200

HL-No.	Dimension	Weight	EAN	Piece/package
3000.1	Ø 110 mm / 121 x 121 mm	425 g	+015337	1
3000Prblue	Ø 110 mm / 121 x 121 mm	482 g	+051977	1
3000FPblue	Ø 110 mm / 121 x 121 mm	446 g	+050574	1

HL3020 Tilable extension
Data

Material	PP, stainless steel V4A
Extension	132 x 132 mm with stainless steel frame, cuttable in height
Grate	Stainless steel frame and special grate, to be filled with tiles; Size of grate: 104 x 104 x 12 mm
Load classification	K 3 - max. 300 kg
Recommended for	e.g. tiled showers, SPA-area
Including	Lot cover

Fits for all drain bodies with higher lot cover HL70K-3020, HL80K-3020, HL90K-3020, HL300K-3020, HL304K-3020, HL310K-3020, HL510K-3020

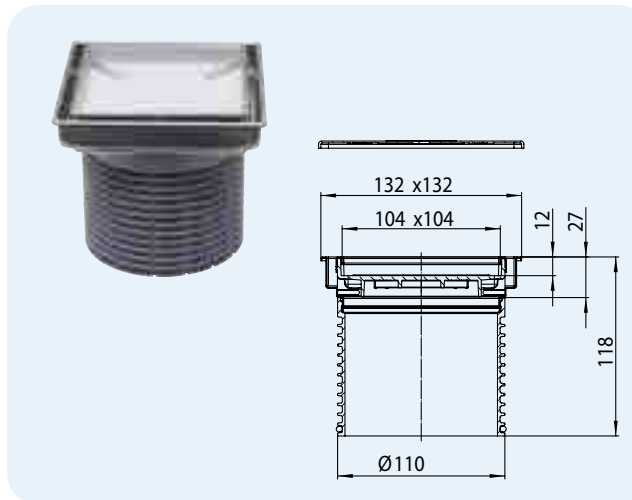

HL-No.	Dimension	Weight	EAN	Piece/package
3020	Ø 110 mm / 132 x 132 mm	350 g	+034253	1

HL37NP Extension with PVC frame and collar
Data

Material	PP/PVC, stainless steel V2A
Extension	PVC frame and collar 185 x 185 mm / 121 x 121 mm, Extension cuttable in height
Grate	Stainless steel grate 115 x 115 mm
Load classification	K 3 – max. 300 kg
Recommended for	PVC floor coverings, for gluing PVC coverings directly on the collar, fits to all floor drains of series HL70, HL80, HL300, HL304, HL310, HL510, HL90

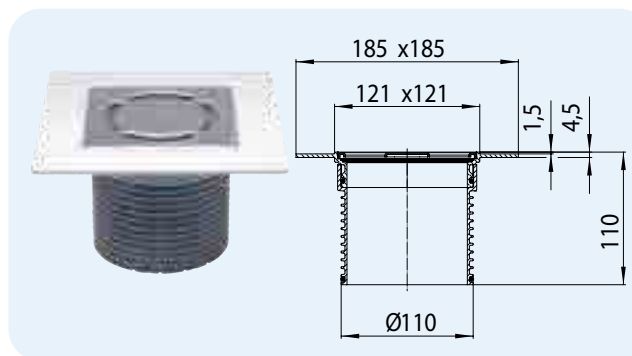

HL-No.	Dimension	Weight	EAN	Piece/package
37NP	Ø 110 mm / 121 x 121 mm	340 g	+022762	1

HL37NP.1 Extension with PVC collar and frame, including water trap

HL37PPrblue Extension with PVC collar and frame, including Primus **blue** trap

Data

Material	PP/PVC, stainless steel V2A
Extension	PVC frame and collar 185 x 185 mm / 121 x 121 mm, Extension cuttable in height
Grate	Stainless steel grate 115 x 115 mm
Stench trap	HL37NP.1: Water trap HL37PPrblue: Primus blue trap
Load classification	K 3 – max. 300 kg
Recommended for	PVC floor coverings, for gluing PVC coverings directly on the collar, fits to all floor drains of series HL310 and HL510

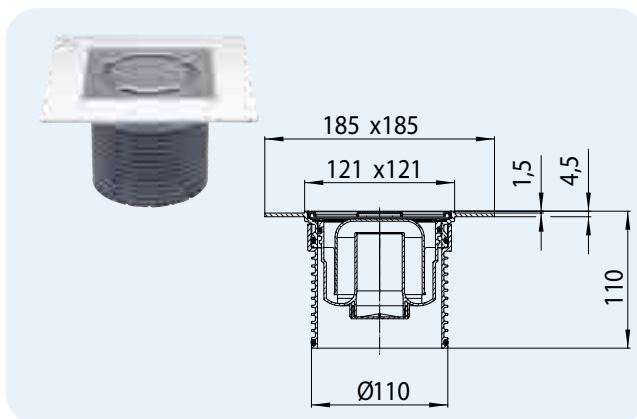

HL-No.	Dimension	Weight	EAN
37NP.1	Ø 110 mm / 121 x 121 mm	342 g	+022805
37PPrblue	Ø 110 mm / 121 x 121 mm	371 g	+052301

HL37NP.1 HL37PPrblue

Piece/package
1
1

HL38P Extension for connection to PVC- and rubber floor coverings

Data

Material	PP/ABS, stainless steel V2A
Extension	Plastic frame 138,5mm
Grate	Stainless steel grate V2A 115mm
Trap	Water trap with 50mm water height
Load classification	K 3 – max. 300 kg
Recommended for	clamping of PVC- or rubber floor coverings from 1-4 mm, fits for drain series HL70, HL80, HL300, HL304 HL310 and HL510

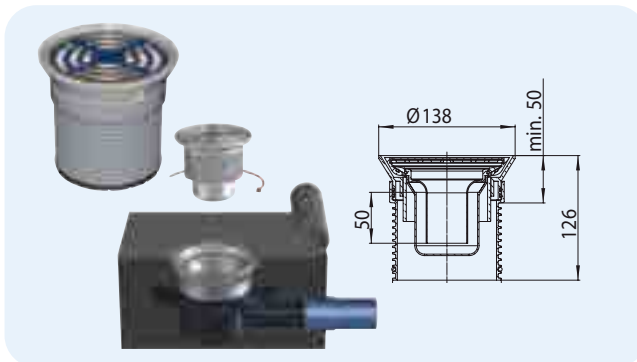

HL-No.	Dimension	Weight	EAN
38P	Ø 110 mm / Ø 115 mm	650 g	+036097



Piece/package
x

HL38N Round extension

Data

Material	PP, stainless steel V2A
Extension	Stainless steel frame Ø 133 mm, extension cuttable in height
Grate	Stainless steel cover plate Ø 112 mm
Load classification	K 3 – max. 300 kg
Recommended for	tiled showers, fitting to floor drain series HL70, HL80, HL90, HL300, HL304

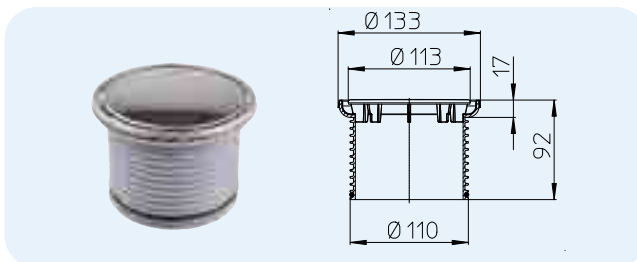

HL-No.	Dimension	Weight	EAN
38N	Ø 110 mm / Ø 133 mm	160 g	+004362



Piece/package
1

HL38N.1 Round extension with water trap

HL38Prblue Round extension with Primus **blue** trap

Data

Material	PP, stainless steel V2A
Extension	Stainless steel frame Ø 133 mm, extension cuttable in height
Grate	Stainless steel cover plate Ø 112 mm
Stench trap	HL38N.1: Water trap HL38Prblue: Primus blue trap
Load classification	K 3 – max. 300 kg
Recommended for	tiled showers, fitting to floor drain series HL310 and HL510

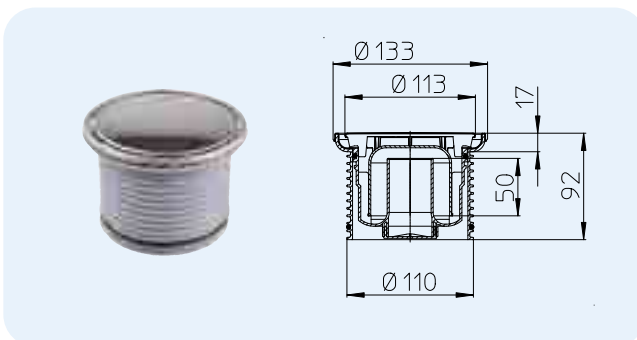

HL-No.	Dimension	Weight	EAN
38N.1	Ø 110 mm / Ø 133 mm	435 g	+015498
38Prblue	Ø 110 mm / Ø 133 mm	494 g	+051984

HL38N.1 HL38Prblue

Piece/package
1
1

HL39G Extension with cast iron frame and grate

Data

Material	PP, cast iron
Extension	Cast iron 150 x 150 mm, extension cuttable in height
Grate	Cast iron 137 x 137 mm
Load classification	L15 bzw. A15 – max. 1,5 t
Recommended for	Mastic asphalt, carparks; Drain bodies of series HL70, HL80, HL300, HL304, HL310, HL510, HL90

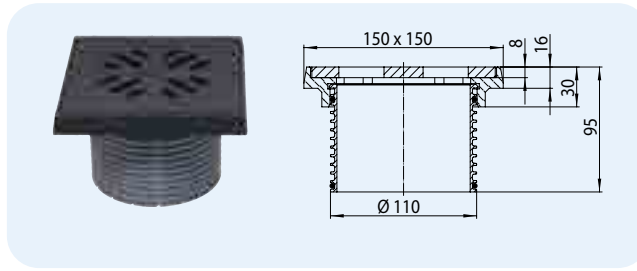

HL-No.	Dimension	Weight	EAN
39G	Ø 110 mm / 150 x 150 mm	2025 g	+000647



Piece/package
1

HL3910 Extension for HL3100 and 5100 series

Data

Material	PP, stainless steel V2A
Extension	Stainless steel frame V4A 145 x 145 mm, extension cuttable in height
Grate	Stainless steel grate V2A 138 x 138 mm
Load classification	K 3 – max. 300 kg
Recommended for	Drain bodies of series HL3100 and HL5100
Including	Supporting frame

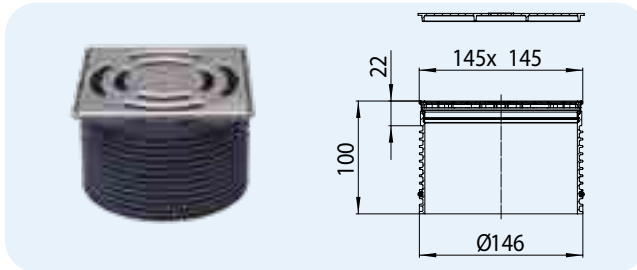

HL-No.	Dimension	Weight	EAN
3910	Ø 146 mm / 145 x 145 mm	467 g	+025534



Piece/package
1

HL3910.1 Extension for series 60 Plus, including water trap HL3910Pr Extension for series 60 Plus, including Primus trap

Data

Material	PP, stainless steel
Extension	Stainless steel frame V4A 145 x 145 mm, extension cuttable in height
Grate	Stainless steel grate V2A 138 x 138 mm
Stench trap	HL3910.1: Water trap HL3910Pr: Primus trap
Load classification	K 3 – max. 300 kg
Recommended for	Drain bodies of series HL3100 and HL5100
Including	Supporting frame

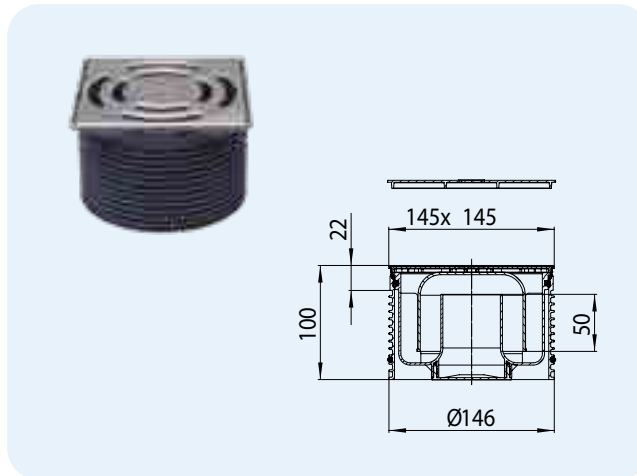

HL-No.	Dimension	Weight	EAN
3910.1	Ø 146 mm / 145 x 145 mm	592 g	+025541
3910Pr	Ø 146 mm / 145 x 145 mm	630 g	+025558



Piece/package
1

HL3911 Extension for series 60 Plus with screwable grate

Data

Material	PP, stainless steel
Extension	Stainless steel frame V4A 145 x 145 mm, extension cuttable in height
Grate	Stainless steel grate V2A 138 x 138 mm
Load classification	K 3 – max. 300 kg
Recommended for	Drain bodies of series HL3100 and HL5100
Including	Supporting frame

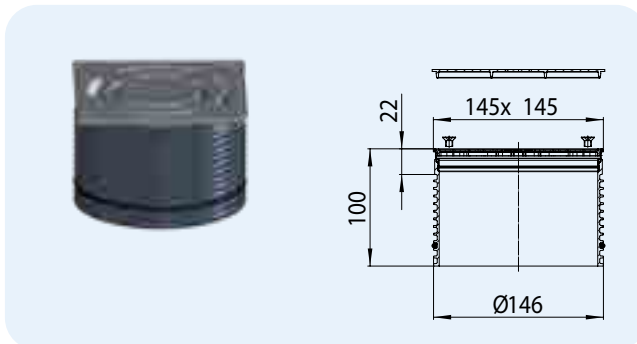

HL-No.	Dimension	Weight	EAN
3911	Ø 146 mm / 145 x 145 mm	470 g	+028252



Piece/package
1

HL3928 Extension „HAMAM“ for floor drain series HL3100 and HL5100
Data

Material	PP, stainless steel
Extension	Brass plated stainless steel V4A frame 145 x 145 mm
Grate	Brass plated stainless steel V2A 138 x 138 mm
Load classification	L 15 - max. 1,5 t
Recommended for	Floor drain series HL3100 and HL5100

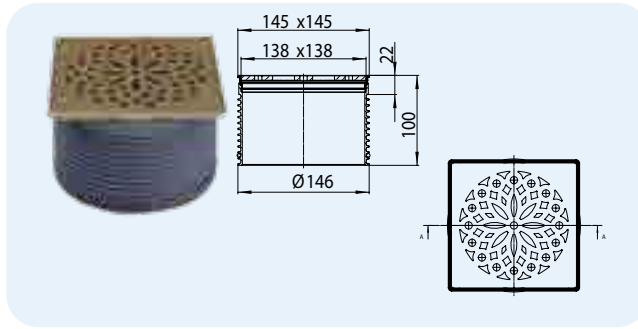

HL-No.	Dimension	Weight	EAN	Piece/package
3928	Ø 146 mm / 145 x 145 mm	776 g	+034796	1

HL3910G Extension cast iron for floor drain series HL3100 and HL5100
HL3910GV Extension cast iron for floor drain series HL3100 and HL5100, screwable
Data

Material	PP, Cast iron
Extension	Cast iron frame 190 x 190 mm, height 45 - 80 mm
Grate	HL3910G: Cast iron grate 175 x 175 mm HL3910GV: Cast iron grate 175 x 175 mm screwable
Load classification	B - 12,5 t
Recommended for	Car parks, warehouses, garbage rooms, mastic asphalt; fits for drain bodies of series HL3100(T) and HL5100(T)

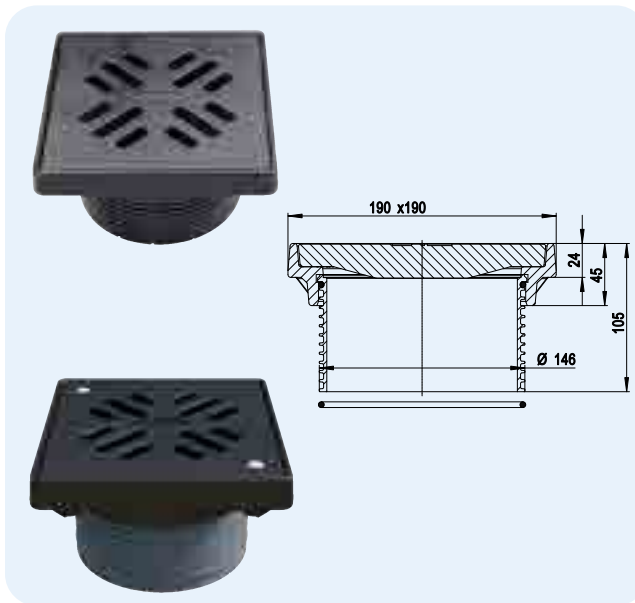

HL-No.	Dimension	Weight	EAN	Piece/package
3910G	Ø 146 mm / 190 x 190 mm	5400 g	+048793	1
3910GV	Ø 146 mm / 190 x 190 mm	5400 g	+003747	1

HL66, HL66Q, HL66.1 Extensions with screwable grate
Data

Material	PP, Stainless steel
Extension	Stainless steel frame V2A, 150 x 150 mm, extension cuttable in height
Grate	HL66 Screwable stainless steel grate V2A 138 x 138 mm HL66Q Design grate V2A 138 x 138 mm „Quadra“ HL66.1 Anti-slip grate V2A 138 x 138 mm, stainless steel, screwable
Load classification	L 15 – max. 1,5 t
Recommended for	Drain bodies of series HL72.1 and HL317

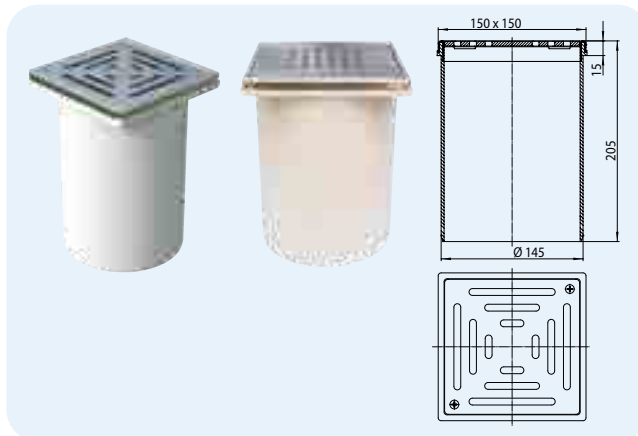

HL-No.	Dimension	Weight	EAN	Piece/package
66	Ø 145 mm / 150 x 150 mm	915 g	+700660	1
66Q	Ø 145 mm / 150 x 150 mm	1070 g	+013609	1
66.1	Ø 145 mm / 150 x 150 mm	1000 g	+702664	1

HL66.3 Extension with stainless steel grate
HL66.4 Extension with plastic grate

Data

Material	HL66.3: PP, Stainless steel V2A HL66.4: PP
Extension	PP-Frame 150 x 150 mm, Extension cuttable in height
Grate	HL66.3: Stainless steel grate 138 x 138 mm HL66.4: Plastic grate 138 x 138 mm
Load classification	K 3 – max. 300 kg
Recommended for	Drain bodies of series HL72.1 and HL317



HL66.3

HL66.4



HL0317.1E



HL072.1E



HL0317.2E

HL-No.	Dimension	Weight	EAN	Piece/package
66.3	Ø 145 mm / 150 x 150 mm	352 g	+014545	1
66.4	Ø 145 mm / 150 x 150 mm	238 g	+014569	1

HL3110, HL03910.3E Stainless steel grate V4A

Data

Material	Stainless steel V4A
Grate	HL3110: Stainless steel grate 115 x 115 mm HL03910.3E: Stainless steel grate 138 x 138 mm
Load classification	K 3 – max. 300 kg
Recommended for	chlorinated sewer, e.g. in swimming pools



HL-No.	Dimension	Weight	EAN	Piece/package
3110	115 x 115 mm	162 g	+015634	1
03910.3E	138 x 138 mm	255 g	+025916	1

HL3120, HL3121, HL3122, HL3123, HL3124, HL3125, HL3127 Design grates

Data

Material	Stainless steel V2A
Grate	Stainless steel grate 115 x 115 mm
Load classification	L – max. 1,5 t
Recommended for	Floor drain series HL70, HL80, HL300, HL304, HL310, HL510, HL90 combined with extensions HL3200 or HL3210

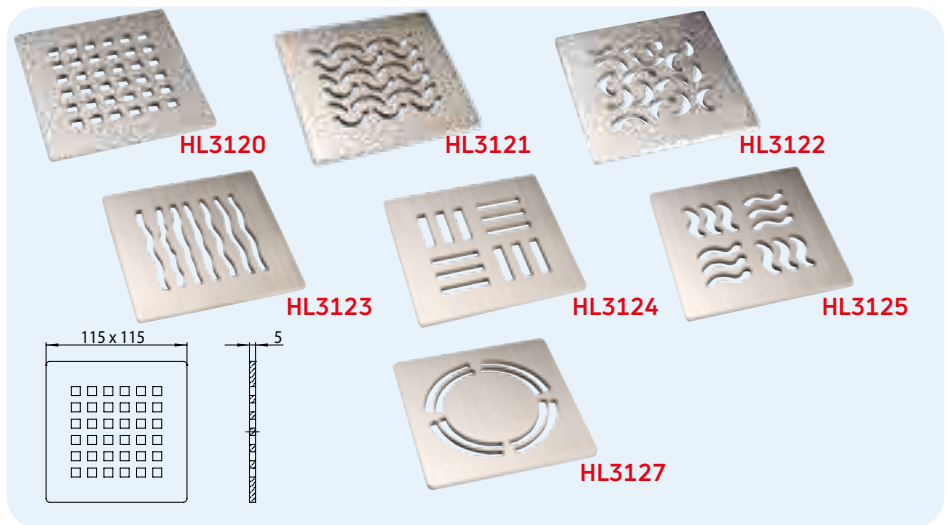

HL-No.	Dimension	Weight	EAN	Piece/package
3120	115 x 115 mm	425 g	+015412	1
3121	115 x 115 mm	425 g	+015429	1
3122	115 x 115 mm	425 g	+015443	1
3123	115 x 115 mm	425 g	+015443	1
3124	115 x 115 mm	425 g	+015450	1
3125	115 x 115 mm	425 g	+015467	1
3127	115 x 115 mm	430 g	+029037	1



SIPHONS ABLÄUFE



Ø 300

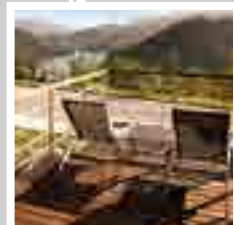
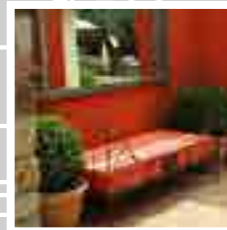

HL Products

Ø 145

14. Sealing kits
Extensions

14

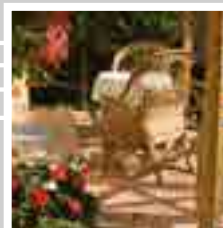

HL Sealing kits – Products – Overview

More details to the chapter „Sealing kits“ please see chapters floor drains, barrier free showers, balcony/terraces and waterproofing

For drain types	Kind of water proofing		
	For 2-component water proofings like epoxy resins or flexible sealing compounds	For EPDM sheetings, bitumen coatings; weldable with bitumen sheetings	For welding of bitumen sheetings
HL83.M = HL70, HL80, HL90, HL92, HL300, HL304, HL310-series, HL510-series Extension: HL85N	 HL83.M	 HL83	 HL83.H *
HL3100(T) and HL5100(T) Extension: HL8500	 HL8300.M	 HL8300	 HL8300.H *
HL72.1 and HL317 Extension: HL350.1	 HL84.M	 HL84	**
HL615 and HL616 Extension: HL618	 HL86.M	 HL86	 HL86.H
Roof drain types HL62, HL63, HL64 and HL69 Extension: HL65	 HL84.L	–	 HL84.H















* also available as drain with prefabricated bitumen flange at drain series HL80, HL615, HL616, roof drain series HL62, HL64, HL63, HL69 and extensions HL85, HL618, HL65.

















** available as drain with prefabricated insulation flange!

*** Sealing kit connectable (without sheeting) with on-site sheetings

PVC-sheetings	FPO-sheetings	For clamping of elastic on-site sheetings	Roofs with copper sheeting	Zinc-plated steel roofs
			-	-
HL83.P	HL83.PP	HL83.0		
			-	-
HL8300.P	HL8300.PP	HL8300.0		
***	***		-	-
		HL84.0		
***	***		-	-
		HL86.0		
**	**	**		
			HL84.CU	HL84.E

HL Extensions – Products – Overview







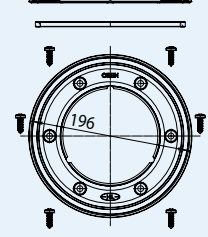

For drain types	For the height adjustment; Connection to 2-component water proofings	For the height adjustment of the flange	For the height adjustment; Connection to bitumen sheetings
HL70, HL80, HL90, HL300, HL304, HL310-series, HL510-series	 <p>HL85N + HL83.M</p>	 <p>HL85N</p>	 <p>HL85NH</p>
HL3100 and HL5100	 <p>HL8500 + HL8300.M</p>	 <p>HL8500</p>	 <p>HL8500H</p>
HL72.1 and HL317	 <p>HL350.0</p>	 <p>HL350.0</p>	 <p>HL350.1H</p>
HL615 and HL616	 <p>HL618 + HL86.M</p>	 <p>HL618</p>	 <p>HL618H</p>
Roof drain types HL62 and HL64	-	 <p>HL65</p>	 <p>HL65H</p>
Balcony and terrace drain HL92	-	-	-

For the height adjustment; Connection to PVC sheetings	For the height adjustment; Connection to FPO sheetings	For the elongation of the extension
 <p>HL85N + HL83.P</p>	 <p>HL85N + HL83.PP</p>	 <p>HL340N</p>
 <p>HL8500 + HL8300.P</p>	 <p>HL8500 + HL8300.PP</p>	 <p>HL3400</p>
 <p>HL350.0</p>	 <p>HL350.0</p>	 <p>HL350</p>
 <p>HL618 + HL86.0</p>	 <p>HL618 + HL86.0</p>	 <p>HL620</p>
 <p>HL65P</p>	 <p>HL65F (HL65PE)</p>	 <p>HL350</p>
<p>-</p>	<p>-</p>	 <p>HL320</p>

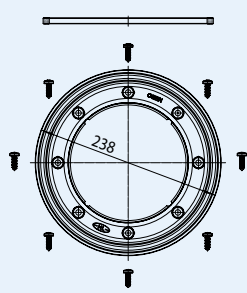
HL Sealing kits – Products – Data

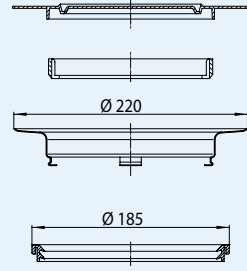
HL83.0, HL8300.0, HL84.0, HL86.0 Sealing kit without water proofing

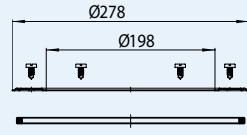
Data	
Material	Stainless steel V2A
Dimension	HL83.0: Ø 196 x 114 mm HL8300.0: Ø 238 x 148 mm HL84.0: Ø 220 x 155 mm HL86.0: Ø 278 x 198 mm
Recommended for	Connection of on-site sheetings to the flange
Fits to	HL83.0: HL70, HL80, HL90, HL92, HL300, HL304, HL310-series, HL510-series and extension element HL85N HL8300.0: HL3100(Pr) and HL5100(Pr) and extension HL8500 HL84.0: HL72.1 and HL317 HL86.0: HL615 and HL616 and extension HL618

<p>HL83.0</p>  	 <p>HL083.1E HL083.2E HL01023D</p>
<p>HL8300.0</p>  	 <p>HL086.1E HL08300.2E HL01092D</p>
<p>HL84.0</p>  	 <p>HL062B.3E HL084.2E HL084.4E</p>
<p>HL86.0</p>  	 <p>HL086.1E HL086.2E HL086.0E</p>

HL-No.	Weight	EAN	Piece/package
83.0	245 g	+718306	1
8300.0	303 g	+025497	1
84.0	395 g	+718405	1
86.0	340 g	+711864	1

HL83.M, HL8300.M, HL84.M, HL86.M Sealing kit with textile coated membrane
Data

Material	Stainless steel V2A/ Textile coated membrane
Dimension	HL83.M: Flange Ø 196 x 114 mm Textile coated membrane 400 x 500 mm HL8300.M: Flange Ø 238 x 148 mm Textile coated membrane 500 x 500 mm HL84.M: Flange Ø 220 x 155 mm Textile coated membrane 500 x 500 mm HL86.M: Flange Ø 278 x 198 mm Textile coated membrane 500 x 500 mm
Recommended for	2-component water proofings like epoxy resins or flexible sealing compounds
Fits to	HL83.M: HL70, HL80, HL90, HL92, HL300, HL304, HL310-series, HL510-series and extension element HL85N HL8300.M: HL3100(Pr) und HL5100(Pr) and Extension HL8500 HL84.M: HL72.1 und HL317 HL86.M: HL615 und HL616 and Extension HL618

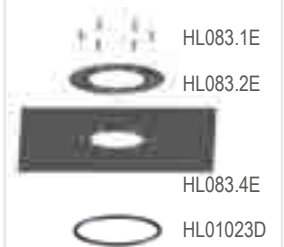
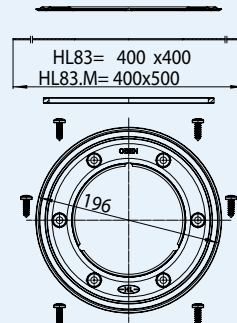
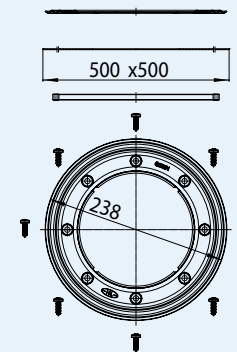
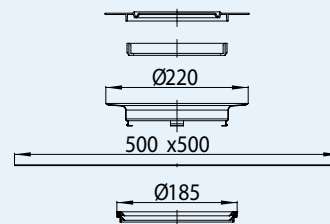
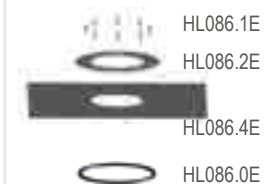
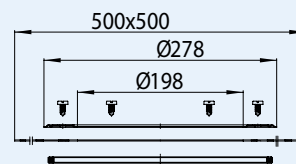
HL83.M

HL8300.M

HL84.M

HL86.M

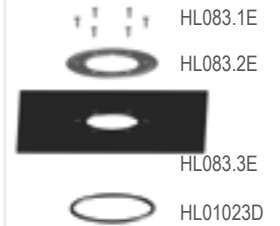
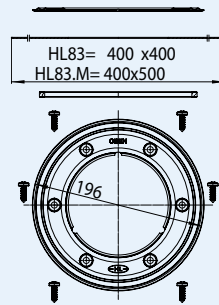
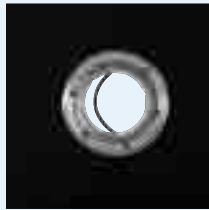
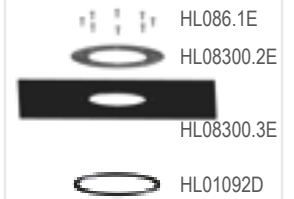
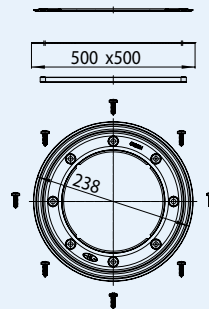
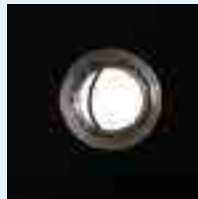
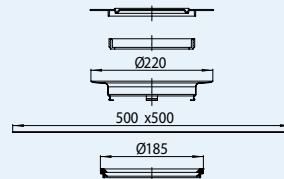
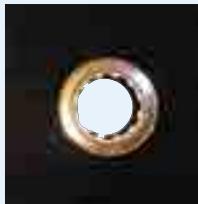
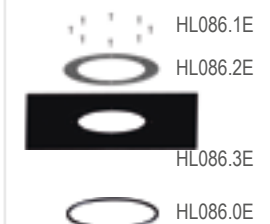
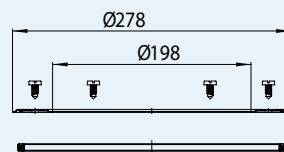
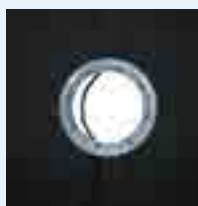
HL-No.	Weight	EAN	Piece/package
83.M	425 g	+030835	1
83.3020	425 g	+034307	1
8300.M	425 g	+025473	1
84.M	730 g	+030842	1
86.M	590 g	+713868	1

HL83, HL8300, HL84, HL86 Sealing kit with EPDM-sheet
Data

Material	Stainless steel V2A/ EPDM
Dimension	HL83: Flange \varnothing 196 x 114 mm EPDM-sheet 400 x 400 mm HL8300: Flange \varnothing 238 x 148 mm EPDM-sheet 500 x 500 mm HL84: Flange \varnothing 220 x 155 mm EPDM-sheet 500 x 500 mm HL86: Flange \varnothing 278 x 198 mm EPDM-sheet 500 x 500 mm
Recommended for	EPDM sheetings, bitumen coatings; weldable with bitumen sheetings
Fits to	HL83: HL70, HL80, HL90, HL92, HL300, HL304, HL310-series, HL510-series and extension element HL85N HL8300: HL3100(Pr) and HL5100(Pr) and Extension HL8500 HL84: HL72.1 and HL317 HL86: HL615 and HL616 and Extension HL618

HL83

HL8300

HL84

HL86

HL-No.	Weight	EAN	Piece/package
83	425 g	+710836	1
8300	601 g	+025466	1
84	730 g	+710843	1
86	590 g	+710867	1

HL83.H, HL8300.H, HL84.H, HL86.H Sealing kit with bitumen sheet

Data

Material: Stainless steel V2A/ bitumen

Dimension: **HL83.H:** Flange Ø 196 x 114 mm
Bitumen collar 500 x 500 mm
HL8300.H: Flange Ø 238 x 148 mm
Bitumen collar 500 x 500 mm
HL84.H: Flange Ø 220 x 155 mm
Bitumen collar 500 x 500 mm
HL86.H: Flange Ø 278 x 198 mm
Bitumen collar 500 x 500 mm

Recommended for: **Welding of bitumen water proofings**

Fits to: **HL83.H:** HL70, HL80, HL90, HL92, HL300, HL304, HL310-series, HL510-series as well as extension element HL85N
HL8300.H: HL3100(Pr) und HL5100(Pr) and Extension HL8500
HL84.H: Roof drain types: HL62, HL64, HL63, Extension: HL65
HL86.H: HL615 und HL616 and Extension HL618

HL83.H

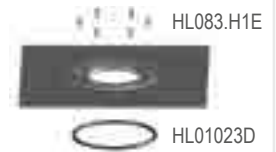
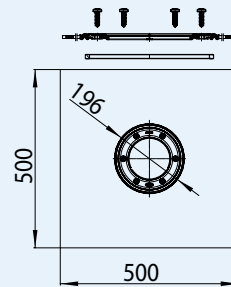

HL8300.H

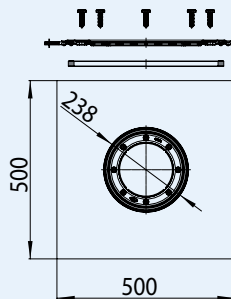

HL84.H

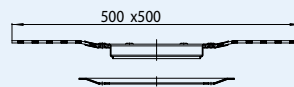

HL86.H

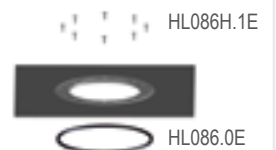
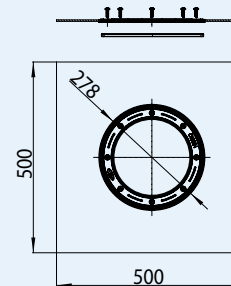

HL-No.	Weight	EAN	Piece/package
83.H	1560 g	+008315	1
8300.H	1560 g	+025480	1
84.H	1707 g	+011841	1
86.H	1590 g	+008612	1

HL83.P, HL83.PP Sealing kit with PVC or PP flange

Data	
Material	HL83.P: PVC HL83.PP: PP
Dimension	HL83.P: Flange Ø 290 mm HL83.PP: Flange Ø 290 mm
Recommended for	HL83.P: PVC sheetings HL83.PP: FPO sheetings, based on PP
Fits to	HL70, HL80, HL90, HL92, HL300, HL304, HL310-series, HL510-series as well as extension element HL85N

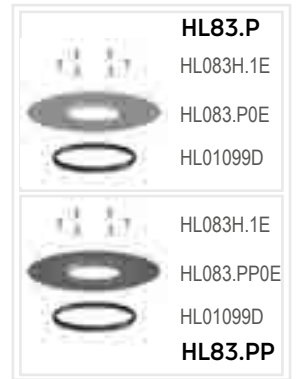
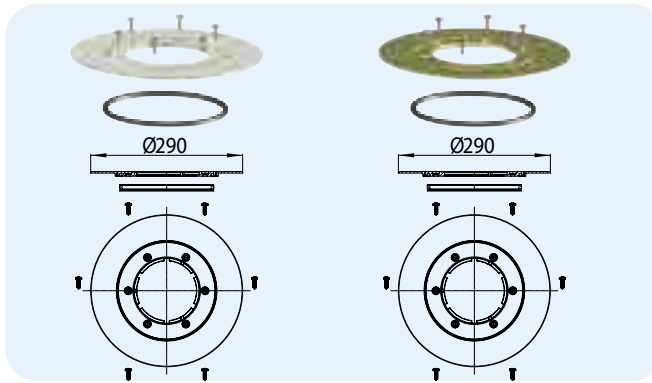

HL-No.	Weight	EAN	Piece/package
83.P	425 g	+010837	1
83.PP	653 g	+028641	1

HL8300.P, HL8300.PP Sealing kit with PVC- respectively PP flange

Data	
Material	HL8300.P: PVC HL8300.PP: PP
Dimension	HL8300.P: Flange Ø 350 mm HL8300.PP: Flange Ø 350 mm
Recommended for	HL8300.P: PVC waterproofings HL8300.PP: FPO waterproofings, based on PP
Fits to	Drain series HL3100 and HL5100, extension HL8500

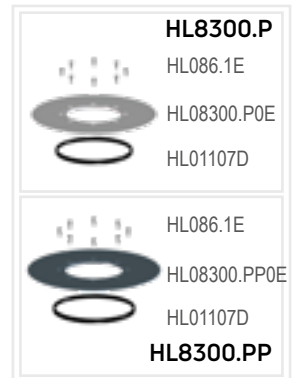
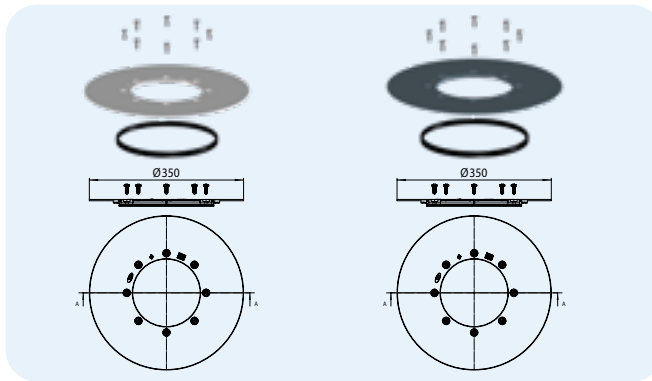

HL-No.	Weight	EAN	Piece/package
8300.P	530 g	+034741	1
8300.PP	320 g	+034758	1

HL84.CU, HL84.E Sealing kit with copper collar or zinc-plated collar

Data	
Material	HL84.CU: Copper HL84.E: Zinc-plated steel
Dimension	HL84.CU: 500 x 500 mm HL84.E: 500 x 500 mm
Recommended for	HL84.CU: Copper roof sheetings HL84.E: Zinc-plated roof sheetings
Fits to	Roof drain series HL62, HL63, HL64, HL65 and HL69

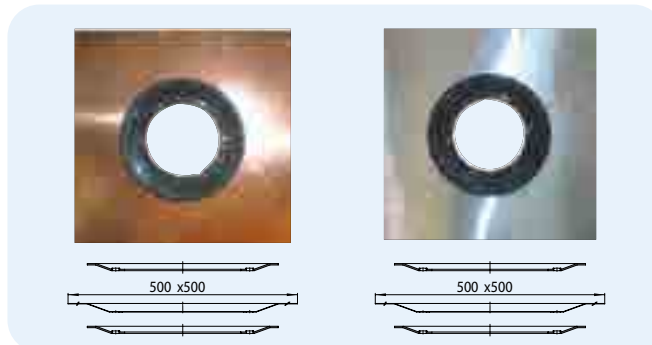

HL-No.	Weight	EAN	Piece/package
84.CU	1835 g	+444847	1
84.E	1830 g	+111848	1

HL84.L Fleece-laminated membrane with TPE clamping area for liquid-waterproofing

Data	
Material	TPE, Fleece-laminated foil
Dimension	500 x 500 mm
Recommended for	Solvent-free liquid-waterproofings
Fits to	HL62, HL64, HL65 with clamping ring

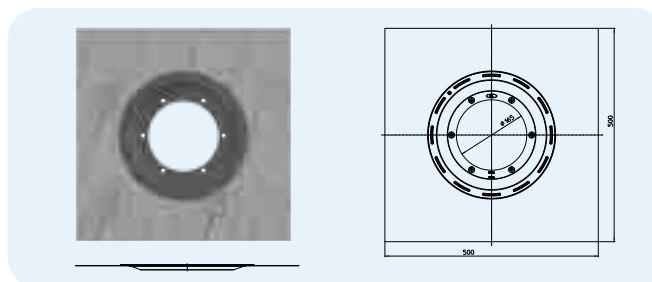

HL-No.	Weight	EAN	Piece/package
84.L	730 g	+000739	1

HL Extensions – Products – Data

HL320, HL340N, HL3400, HL350, HL620 Extension

Data

Material	PP
Dimension	HL320: Ø 90 mm, h: 35 mm HL340N: Ø 110 mm, h: 100 mm HL3400: Ø 146 mm, h: 200 mm HL350: Ø 145 mm, h: 130 mm HL620: Ø 195 mm, h: 100 mm
Recommended for	Height adjustment of the drain
Fits to	HL320: HL92 HL340N: HL70, HL80, HL90, HL300, HL304, HL310-series, HL510-series and extension element HL85N HL3400: Series HL3100 and HL5100 HL350: HL72.1, HL317, HL62, HL63, HL64, HL65, HL69 HL620: HL615 und HL616

HL320

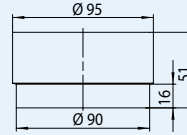

HL340N

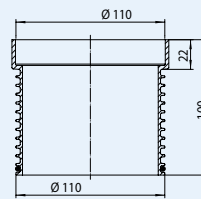

HL01067D

HL3400

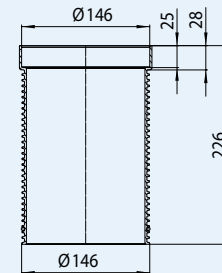

HL01093D

HL350

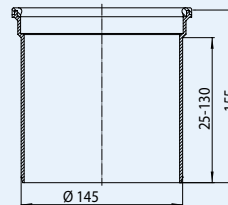

HL620

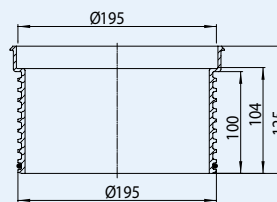

HL01056D

HL-No.	Weight	EAN	Piece/package
340N	75 g	+003402	1
3400	117 g	+025565	1
350	240 g	+703500	1
620	270 g	+014255	1

HL85N, HL8500, HL350.1, HL350.0, HL618, HL65 Extension with flange

Data

Material	PP
Dimension	<p>HL85N: Ø 110 x 220 mm, h: 204 mm</p> <p>HL8500: Ø 146 x 239 mm, h: 202 mm</p> <p>HL350.1 (HL350.0): Ø 145 x 300 mm, h: 180 mm</p> <p>HL618: Ø 195 x 315 mm, h: 95 mm</p> <p>HL65: Ø 125 x 354 mm, h: 260 mm</p>
Recommended for	Height adjustment of the drain to the water proofing level
Fits to	<p>HL85N: HL70, HL80, HL90(Pr), HL300, HL304, HL310-series, HL510-series</p> <p>HL8500: HL3100(Pr) and HL5100(Pr)</p> <p>HL350.1 (HL350.0): HL72.1, HL317, HL62, HL63, HL64, HL65 and HL69</p> <p>HL618: HL615, HL616</p> <p>HL65: HL62, HL64</p>

HL85N

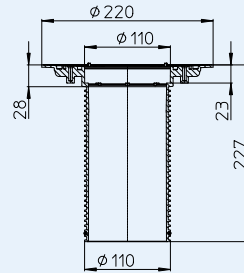

HL01067D

HL8500

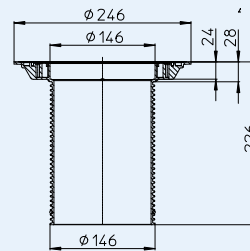

HL03100.0E

HL01093D

HL350.1 (HL350.0)

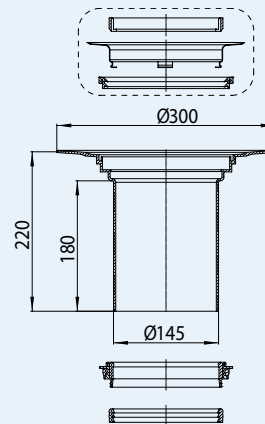

HL062B.3E

HL084.2E

HL084.3E

HL084.4E

HL01059D HL01058D

HL618

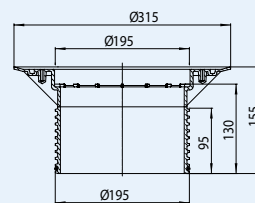

HL01056D

HL65

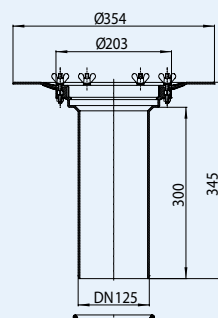

HL062.4E

HL170

HL062.3E

HL01020D

HL-No.	Weight	EAN	Piece/package
85N	395 g	+006120	1
8500	320 g	+025572	1
350.0	680 g	+032358	1
350.1	1440 g	+703517	1
618	500 g	+013159	1
65	1440 g	+800650	1

HL85NH, HL8500H, HL350.1H, HL618H, HL65H Extension with bitumen welded flange
Data

Material	PP / stainless steel / bitumen
Dimension	HL85NH: Ø 110 mm, h: 204 mm, Bitumen collar: Ø 420 mm HL8500H: Ø 146, h: 202 mm, Bitumen collar: 500 x 500 mm HL350.1H: Ø 145, h: 180 mm, Bitumen collar: Ø 500 mm HL618H: Ø 195 mm, h: 95 mm, Bitumen collar: 500 x 500 mm HL65H: Ø 125 mm, h: 260 mm, Bitumen collar: Ø 500 mm
Recommended for	Bitumen waterproofings
Fits to	HL85NH: HL70, HL80, HL90, HL300, HL304, HL310-series, HL510-series HL8500H: HL3100(Pr)(T), HL5100 (Pr)(T) HL350.1H: HL72.1, HL317, HL62, HL63, HL64, HL65, HL69 HL618H: HL615 and HL616 HL65H: HL62, HL64

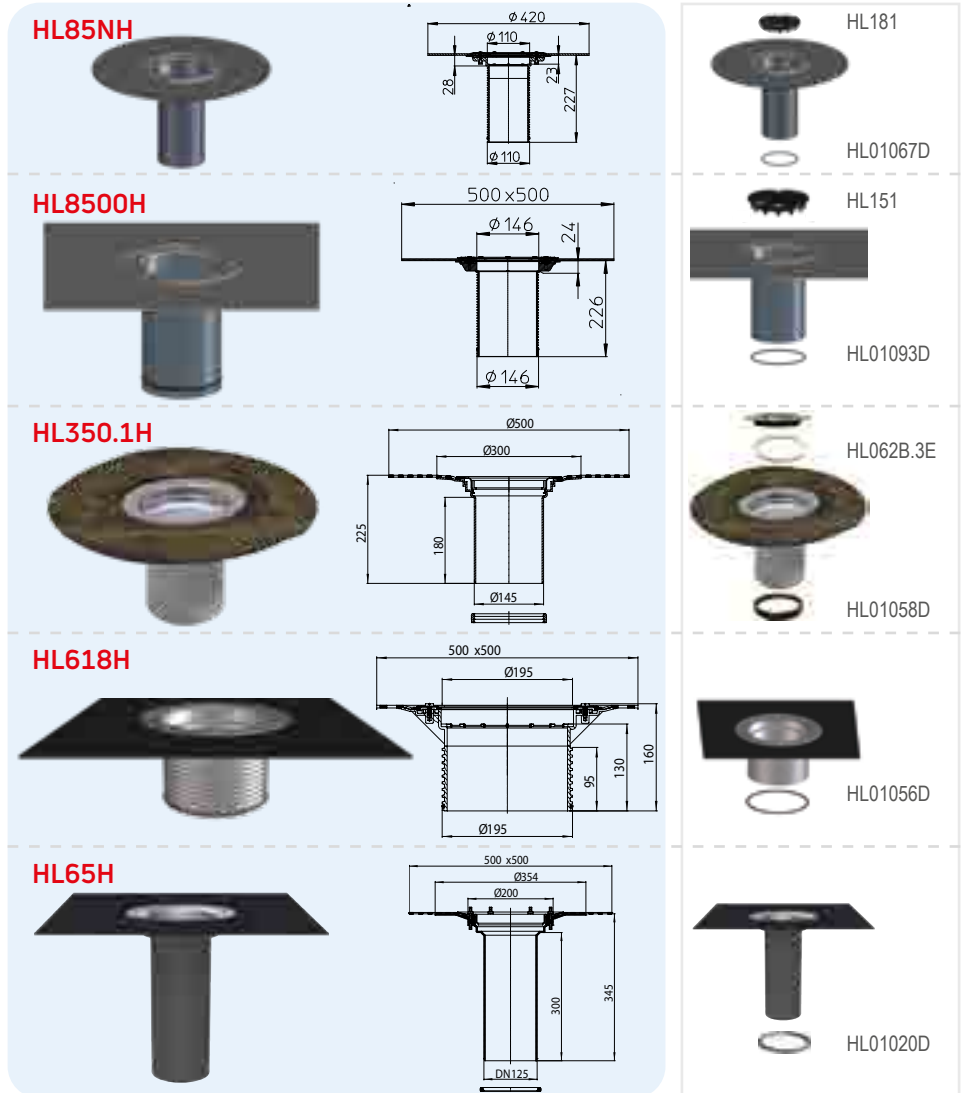

HL-No.	Weight	EAN	Piece/package
85NH	980 g	+009015	1
8500H	2346 g	+034765	1
350.1H	1550 g	+001842	1
618H	1750 g	+013173	1
65H	2140 g	+801657	1

HL65P, HL65F, HL65PE Extension with PVC flange or PP flange
Data

Material	HL65P: PVC HL65F: PP HL65PE: PE
Dimension	HL65P: Ø 125 mm, h: 350 mm, Flange: Ø 354 mm HL65F, HL65PE: Ø 125 mm, h: 345 mm, Flange: Ø 355 mm
Recommended for	HL65P: PVC roof sheetings HL65F: FPO roof sheetings, based on PP HL65PE: FPO roof sheetings, based on PE
Fits to	roof drains HL62 and HL64

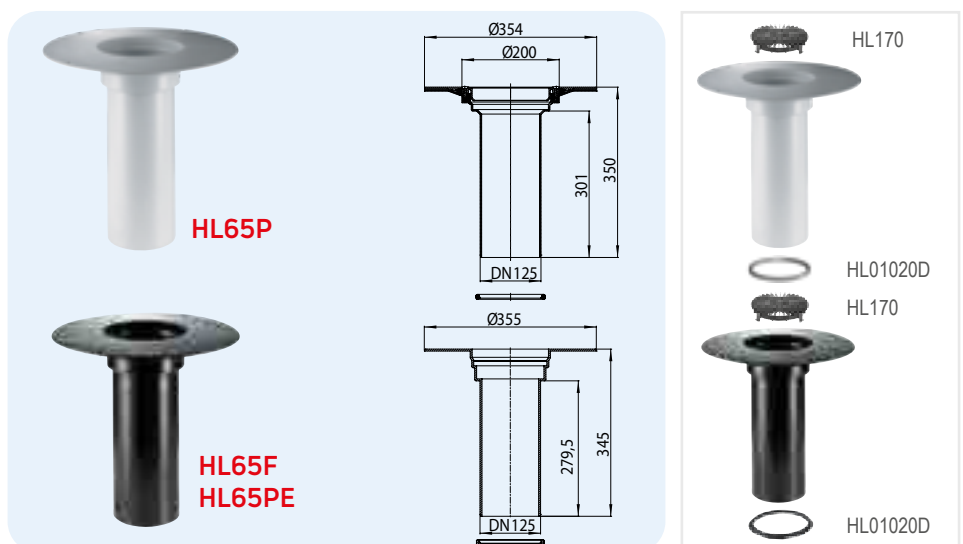

HL-No.	Weight	EAN	Piece/package
65P	1370 g	+022588	1
65F	830 g	+031900	1
65PE	850 g	+035915	1



SIPHONS ABLÄUFE

Ø 315

260 x 260

55-130

260



HL Major drains

15. Terraces, patios,
car parks a.s.o.

15

PERFECT SERIES

DN110



HL Major drains PERFECT SERIES

Basic information about design and installation

When designing big open spaces, car parkings or roof terraces, the drainage of rain water becomes more and more important due to the increasing rainfall. For this reason we would like to bring closer to you the different combination possibilities of our drain series „Perfect“.

▲ Calculation of the quantity of drains:

For the calculation of the quantity of the fitting drains we recommend to use as a basis the standard rain yield factor of 400 l / (s x ha), according EN12056. Please find examples in chapter „Flat roof drains“.

▲ Adjustment of the grate level to the level of the pavement:

When connecting the drain to the sewage pipe, one has often the problem, that the final height level is not yet fixed or known. That means, that in advance it is nearly impossible to reach the right final level of the pavement.

Therefore we recommend the usage of two-part drains: First you connect the drain body to the sewage pipe; in this phase the drain body works as a temporary drainage. When the further pavement (asphalt, concrete, cobblestone..) is known, the extension is set on the drain body and may be adjusted in height simply by cutting. That eases the creation of the slope to the drain.

▲ Load classifications

When selecting the drain please take care to use the right load classification according EN1253. With our „Perfect“-series you may reach load classifications A015, B125, H1,5, K3, L15 and M125, depending on the material of the grate or the frame. At the installation you have to care for a stable relining of the frame to reach a smooth force distribution to the subsoil.

▲ May plastic drains be used also for mastic asphalt?

The advantages of plastic drains, namely low weight and therefore easy handling, are wellknown. By using combinations of plastic drain bodies and massive cast iron frames and grates the direct setting into mastic asphalt with high temperatures is possible.

▲ Stench trap

In principle rainwater should be connected to a special rainwater duct or should be oozed away (acc. DIN1986-100). Should this not be possible, one should avoid the rise of stench from the sewage system to the drain by using traps. For inside HL provides normal water traps, for outside we recommend the usage of frost-proof flaps.

Relevant standards/directives

ÖNORM B 2501 Drainage of buildings
 DIN 1986-100 Drainage systems for buildings and estates
 EN 1253..... Drains for buildings

ÖNORM B2209 Waterproofing works
 ÖNORM B2220 Roof waterproofings with bitumen and plastic sheetings
 ÖNORM B7209 Waterproofings for buildings
 ÖNORM B7220 Roofs with waterproofings

Selection of the convenient drain

Selective criteria	Requirements	Product
Drainage surface	<p>When you calculate the quantity of occurring rain water acc. ÖNORM B2501 and DIN 1986-100, you have to use at least the standard rain yield factor of 300 l/ (s x ha).</p> <p>Quantity of rain water = 0,03 l/s x Drainage surface (m²)</p> <p>Quantity of drains = $\frac{\text{Absolute quantity of rain water}}{\text{Capacity of the gully}}$</p>	<p>For calculating the right drain and the requested quantity of drains please note the capacity of the particular product.</p>
Floor construction	<p>To find out, what is the best composition of the drain, like extension (with or without flange), gravel guard or heating, a detailed plan of the different layers is necessary.</p>	<p>Extension (with or without flange) Sealing kit Gravel guard Eventually heating</p>
Waterproofing	<p>Please prefer drains with prefabricated bitumen flanges, when the floor is sheeted with bitumen. For all other waterproofing materials you can use the sealing set, which fits to the used waterproofing material.</p> <p>Bitumen waterproofings, liquid bitumen sheetings or compounds</p> <p>Polymer sheetings like PVC</p> <p>Liquid compounds</p>	<p>Drain vertical HL616(.1)H Drain horizontal HL615(.1)H Drain vertical HL616(.1) + Sealing kit HL86.0 Drain horizontal HL615(.1) + Sealing kit HL86.0 Drain vertical HL616(.1) + Sealing kit HL86.M Drain horizontal HL615(.1) + Sealing kit HL86.M</p>
Load classifications	<p>The load classifications of the different drains are depending on the material of the frame or the grate. Load classifications according EN 1253:</p> <p>Classification A up to max. 1,5 t for cast iron, plastic(L) and stainless steel(S) frame</p> <p>Classification B up to max. 12,5 t for cast iron frame and grate</p>	<p>Drain horizontal: HL605(L)(S), HL615(L)(S) Drain vertical: HL606(L)(S),HL616(L)(S) Drain horizontal: HL605.1, HL615.1 Drain vertical: HL606.1, HL616.1</p>

HL Major drains PERFECT SERIES – Sectional drawings

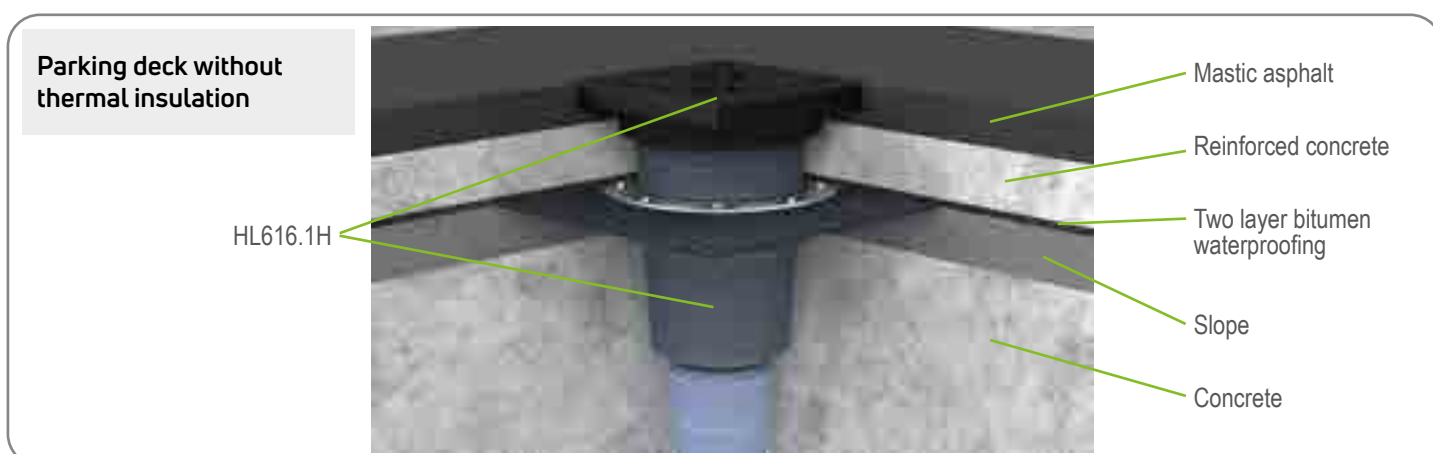
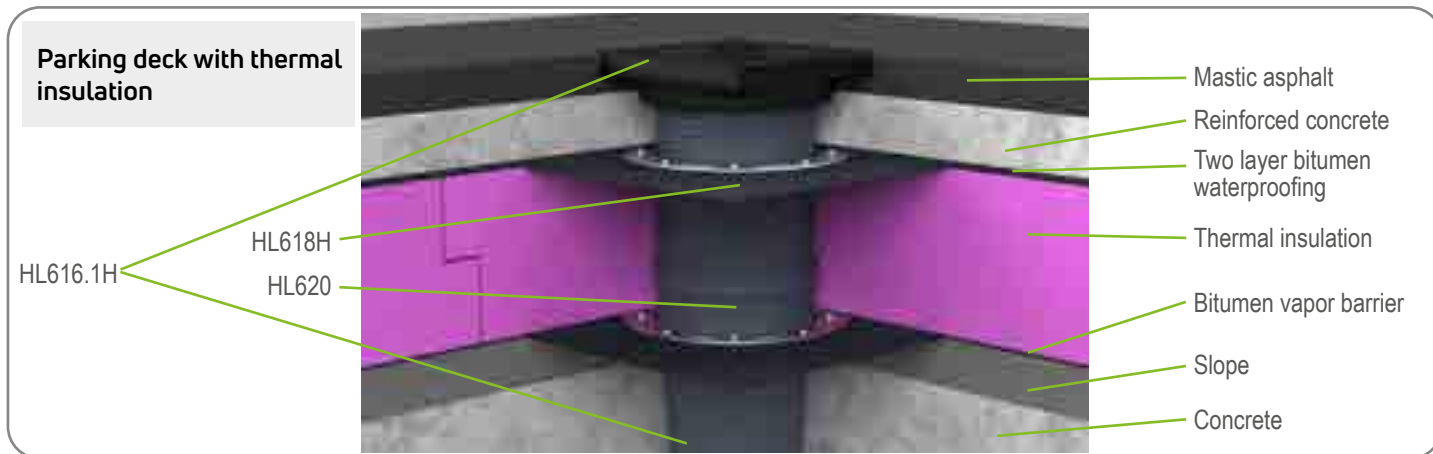
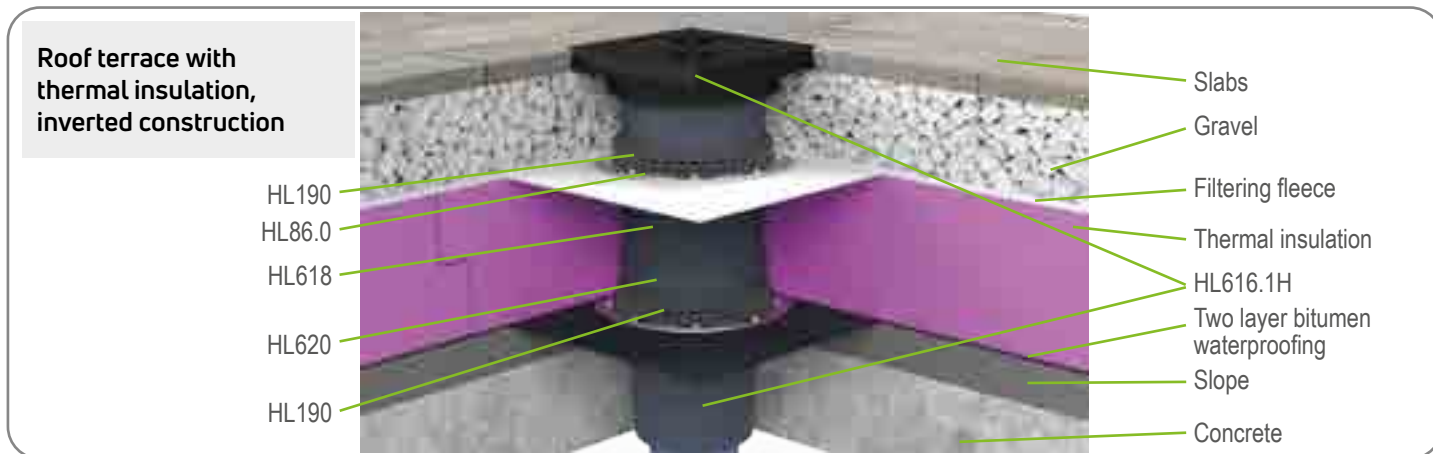

HL Major drains PERFECT SERIES – Installation

Installation example HL616H



1. Create taphole with Ø 300 mm, apply prime coat, apply first bitumen layer



2. Insert major drain HL616H



3. Weld on the bitumen flange on the first bitumen layer



4. Connect second bitumen layer with the bitumen flange



5. Ready connection of the drain to the two-layer waterproofing



6. Remove lid cover, adjust the extension in height by cutting



7. Cover the extension with the fleece, lay on the construction steel



8. Pour out with concrete



9. Remove the grate and insert the gravel catcher



10. Ready

HL Major drains PERFECT SERIES – Products – Overview

Drains



Product	HL605(L)(S)	HL605.1	HL615(L)(S)	HL615.1	HL615H(L)(S)	HL615.1H
Description	Major drain horizontal with plastic frame, one-piece	Major drain horizontal with cast iron frame, one-piece	Major drain horizontal with flange and plastic frame, two-piece	Major drain horizontal with flange and cast iron frame and grate, two-piece	Major drain horizontal with bitumen flange and plastic frame, two-piece	Major drain horizontal with bitumen flange and cast iron frame and grate, two-piece
Function	HL605 with cast iron grate, HL605L with plastic grate, HL605S with stainless steel grate	Load classification B – max. 12,5 t	HL615 with cast iron grate, HL615L with plastic grate, HL615S with stainless steel grate	Load classification B – max. 12,5 t	HL615H with cast iron grate, HL615HL with plastic grate, HL615HS with stainless steel grate	Load classification B – max. 12,5 t

Extensions

Product data see chapter „Sealing kits / Extensions“



Product	HL620	HL618	HL618H
Description	Standard extension	Extension with flange	Extension with bitumen flange
Function	Elongation of the extension	Adjustment of the drain in height to the sealing level	Adjustment of the drain in height to the bitumen waterproofing level

Extensions



Product	HL621	HL622	HL622/S	HL623	HL624 / HL624V
Description	Extension with plastic frame and cast iron grate	Extension with plastic frame and screwable stainless steel grate	Extension with plastic frame and screwable V4A stainless steel grate	Extension with plastic frame and screwable plastic grate	Extension with cast iron frame and cast iron grate, HL624V: screwable
Function	fits to all major drains	fits to all major drains	fits to all major drains	fits to all major drains	fits to all major drains

HL Major drains PERFECT SERIES – Products – Overview

Drains



HL606(L)(S)

Major drain vertical with plastic frame, one-piece

HL606 with cast iron grate,
HL606L with plastic grate,
HL606S with stainless steel grate

HL606.1

Major drain vertical with cast iron frame and cast iron grate, one-piece

Load classification B – max. 12,5 t

HL616(L)(S)

Major drain vertical with flange and plastic frame, two-piece

HL616 with cast iron grate,
HL616L with plastic grate,
HL616S with stainless steel grate

HL616.1

Major drain vertical with flange, cast iron frame and cast iron grate, two-piece

Load classification B – max. 12,5 t

HL616H(L)(S)

Major drain vertical with bitumen flange and plastic frame, two-piece

HL616H with cast iron grate,
HL616HL with plastic grate,
HL616HS with stainless steel grate

HL616.1H

Major drain with bitumen flange, cast iron frame and cast iron grate, two-piece

Load classification B – max. 12,5 t

Accessories



Product

HL190

HL195

HL191

HL609

HL619

Description

Gravel guard

Leaf catcher

Gravel trap

Heating kit

Fixing lugs

Function

Drainage of rainwater on the sealing level, e.g. with inverted constructions

For non-walkable surfaces like gravel, grass

For flaged floors, set into gravel embankment, below the slab

For the heating of the drain, to avoid ice

For fixing the drain and the extension

Sealing kits



Product data see chapter „Sealing kits / Extensions“

Product

HL86.0

HL86

HL86.M

HL86.H

Description

Sealing kit without foil

Sealing kit with EPDM-foil

Sealing kit with textile coated membrane

Sealing kit with bitumen membrane

Function

For clamping of local waterproofings

For bitumen coatings and EPDM-foils

For liquid sealing compounds

For bitumen waterproofings and liquid bitumen compounds

HL Major drains PERFECT SERIES – Products – Data

HL605 Major drain PERFECT with plastic frame

Data

Material	PP
Grate	226 x 226 mm HL605, HL605W: Cast iron HL605L, HL605LW: Plastic HL605S, HL605SW: Stainless steel
Stench trap	HL605, HL605L, HL605S: Frost-proof flap HL605W, HL605LW, HL605SW: Water trap
Standard	EN 1253
Load classification	A – max. 1,5 t L – max. 1,5 t
Additional information	Recess dimension min. 300 x 360 mm Heating set HL609 for heating of the drain body available

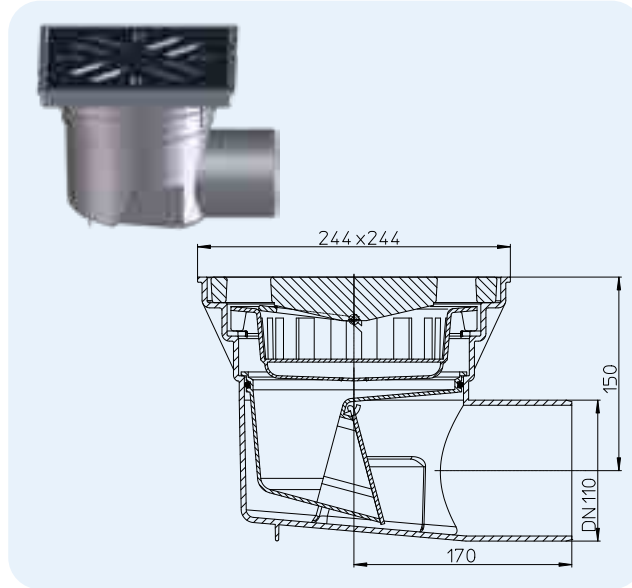

HL-No.	Dimension	Weight	Stench trap	Grate	EAN	Piece/package
605	DN110	7025 g	Frost-proof flap	Cast iron	+006687	1
605L	DN110	1495 g	Frost-proof flap	Plastic	+009336	1
605S	DN110	2790 g	Frost-proof flap	Stainless steel	+010882	1
605W	DN110	6980 g	Water trap	Cast iron	+011070	1
605LW	DN110	1495 g	Water trap	Plastic	+009350	1
605SW	DN110	2790 g	Water trap	Stainless steel	+011117	1

HL605.1 Major drain PERFECT with cast iron frame and cast iron grate

Data

Material	PP
Grate	Cast iron 226 x 226 mm, Cast iron frame 260 x 260 mm
Stench trap	HL605.1: Frost-proof flap HL605.1W: Water trap
Standard	EN 1253
Load classification	B – max. 12,5 t
Additional information	Recess dimension min. 300 x 360 mm Heating set HL609 for heating of the drain body available

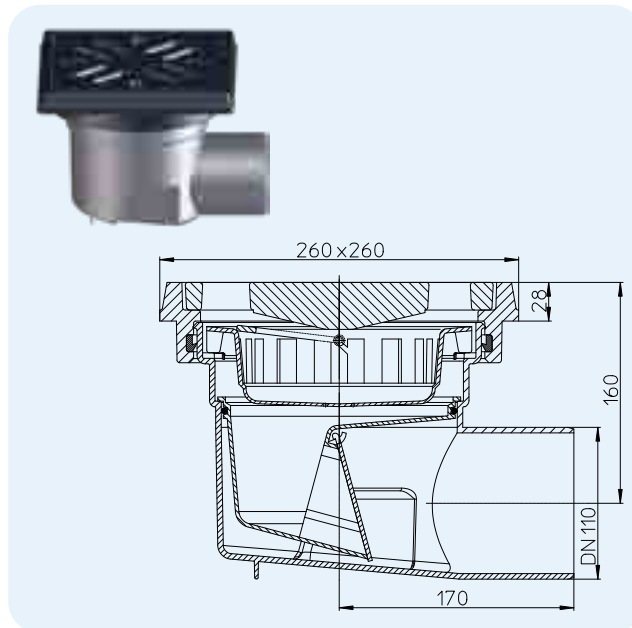

Capacity table HL605, HL605.1

Tested acc. to EN 1253-2:2015 acc. to pt. 5.5.2.1 Fig. 10a) + 10b) and pt. 5.5.1.2 Fig. 9

Drainage capacity measured according to EN 1253-2:2015 according to pt. 5.5.2.1 on downpipe 3 m

Nominal width	EN 1253	5 mm	15 mm	25 mm	35 mm	45 mm	55 mm	65 mm	75 mm
DN 110 horizontal	min. 4,5 (35 mm)	0,80	2,15	4,30	6,10	6,20	6,30	6,65	6,70

Drainage capacity measured according to EN 1253-2:2015 according to clause 5.5.1.2 free draining

Nominal width	EN 1253	5 mm	15 mm	20 mm	35 mm	45 mm	55 mm	65 mm	75 mm
DN 110 horizontal	min. 1,4 (20 mm)	1,05	3,20	3,90	4,65	4,80	4,90	5,05	5,20

HL-No.	Dimension	Weight	Stench trap	Grate	EAN	Piece/package
605.1	DN110	11815 g	Frost-proof flap	Cast iron	+006700	1
605.1W	DN110	11810 g	Water trap	Cast iron	+011094	1

HL606 Major drain PERFECT with plastic frame

Data

Material	PP
Grate	226 x 226 mm HL606/1, HL606/5, HL606W/1, HL606W/5: Cast iron HL606L/1, HL606L/5, HL606LW/1, HL606LW/5: Plastic HL606S/1, HL606S/5, HL606SW/1, HL606SW/5: Stainless steel
Stench trap	HL606/1, HL606L/1, HL606S/1, HL606/5, HL606L/5, HL606S/5: Frost-proof flap HL606W/1, HL606LW/1, HL606SW/1, HL606W/5, HL606LW/5, HL606SW/5: Water trap
Standard	EN 1253
Load classification	A – max. 1,5 t L – max. 1,5 t
Additional information	Heating set HL609 for heating of the drain body available

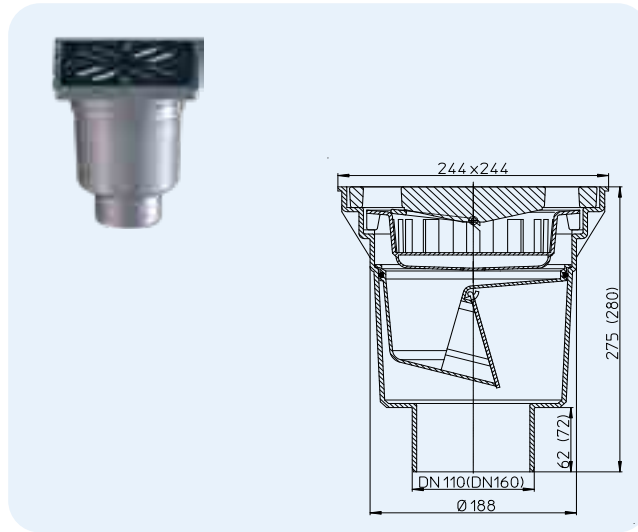

HL-No.	Dimension	Weight	Stench trap	Grate	EAN	Piece/ package
606/1	DN110	7280 g	Frost-proof flap	Cast iron	+906062	1
606/5	DN160	7375 g	Frost-proof flap	Cast iron	+976065	1
606L/1	DN110	1460 g	Frost-proof flap	Plastic	+009374	1
606L/5	DN160	1465 g	Frost-proof flap	Plastic	+009398	1
606S/1	DN110	2755 g	Frost-proof flap	Stainless steel	+010905	1
606S/5	DN160	2760 g	Frost-proof flap	Stainless steel	+010929	1
606W/1	DN110	6980 g	Water trap	Cast iron	+011131	1
606W/5	DN160	6990 g	Water trap	Cast iron	+011155	1
606LW/1	DN110	1460 g	Water trap	Plastic	+009411	1
606LW/5	DN160	1465 g	Water trap	Plastic	+009435	1
606SW/1	DN110	2755 g	Water trap	Stainless steel	+011216	1
606SW/5	DN160	2760 g	Water trap	Stainless steel	+011230	1

HL606.1 Major drain PERFECT with cast iron frame and cast iron grate

Data

Material	PP
Grate	Cast iron 226 x 226 mm, Cast iron frame 260 x 260 mm
Stench trap	HL606.1/1, HL606.1/5: Frost-proof flap HL606.1W/1, HL606.1W/5: Water trap
Standard	EN 1253
Load classification	B – max. 12,5 t
Additional information	Heating set HL609 for heating of the drain body available

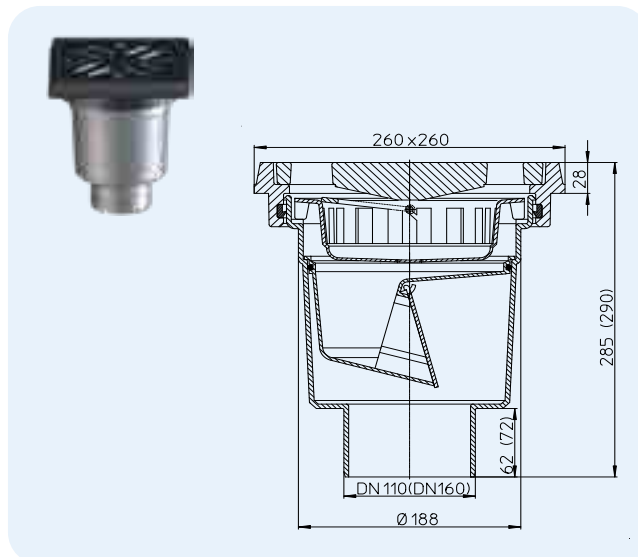

Capacity table HL606, HL606.1

Tested acc. to EN 1253-2:2015 acc. to pt. 5.5.2.1 Fig. 10(a) + 10(b) and pt. 5.5.1.2 Fig. 9
Drainage capacity measured according to EN 1253-2:2015 according to pt. 5.5.2.1 on downpipe 3 m

Nominal width	EN 1253	5 mm	15 mm	25 mm	35 mm	45 mm	55 mm	65 mm	75 mm
DN 110 vertical	min. 4,5 (35 mm)	0,90	2,50	5,80	6,20	6,25	6,30	6,35	6,50
DN 160 vertical	min. 8,1 (35 mm)	1,15	3,00	5,20	5,40	5,60	5,65	5,80	6,00

Drainage capacity measured according to EN 1253-2:2015 according to clause 5.5.1.2 free draining

Nominal width	EN 1253	5 mm	15 mm	20 mm	35 mm	45 mm	55 mm	65 mm	75 mm
DN 110 vertical	min. 1,4 (20 mm)	0,75	2,50	3,45	5,70	5,90	5,95	6,00	6,15
DN 160 vertical	min. 4 (20 mm)	0,75	2,95	3,55	4,85	5,00	5,15	5,20	5,35

HL-No.	Dimension	Weight	Stench trap	Grate	EAN	Piece/ package
606.1/1	DN110	12400 g	Frost-proof flap	Cast iron	+960613	1
606.1/5	DN160	12775 g	Frost-proof flap	Cast iron	+970612	1
606.1W/1	DN110	11860 g	Water trap	Cast iron	+011193	1
606.1W/5	DN160	11870 g	Water trap	Cast iron	+011179	1

HL615 Major drain PERFECT with flange and plastic frame, two piece

Data

Material	PP
Grate	226 x 226 mm HL615, HL615W: Cast iron HL615L, HL615LW: Plastic HL615S, HL615SW: Stainless steel
Stench trap	HL615, HL615L, HL615S: Frost-proof flap HL615W, HL615LW, HL615SW: Water trap
Standard	EN 1253
Load classification	A – max. 1,5 t L – max. 1,5 t
Additional information	Recess dimension min. 290 x 380 mm Heating set HL609 for heating of the drain body available
Including	Lid cover

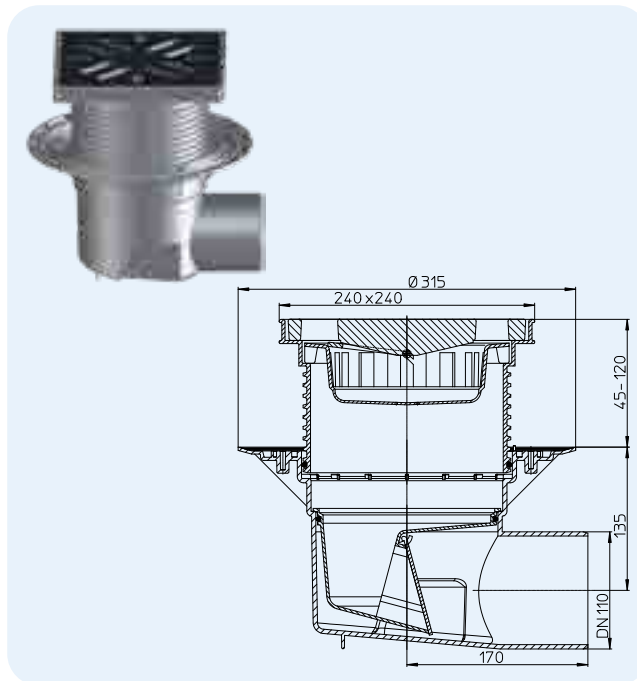

HL-No.	Dimension	Weight	Stench trap	Grate	EAN	Piece/package
615	DN110	7440 g	Frost-proof flap	Cast iron	+006748	1
615L	DN110	1920 g	Frost-proof flap	Plastic	+009459	1
615S	DN110	3215 g	Frost-proof flap	Stainless steel	+010943	1
615W	DN110	7440 g	Water trap	Cast iron	+011254	1
615LW	DN110	1920 g	Water trap	Plastic	+009473	1
615SW	DN110	3215 g	Water trap	Stainless steel	+011292	1

HL615.1 Major drain PERFECT with flange, cast iron frame and cast iron grate, two-piece

Data

Material	PP
Grate	Cast iron 226 x 226 mm Cast iron frame 260 x 260 mm
Stench trap	HL615.1: Frost-proof flap HL615.1W: Water trap
Standard	EN 1253
Load classification	B – max. 12,5 t
Additional information	Recess dimension min. 290 x 380 mm Heating set HL609 for heating of the drain body available
Including	Lid cover

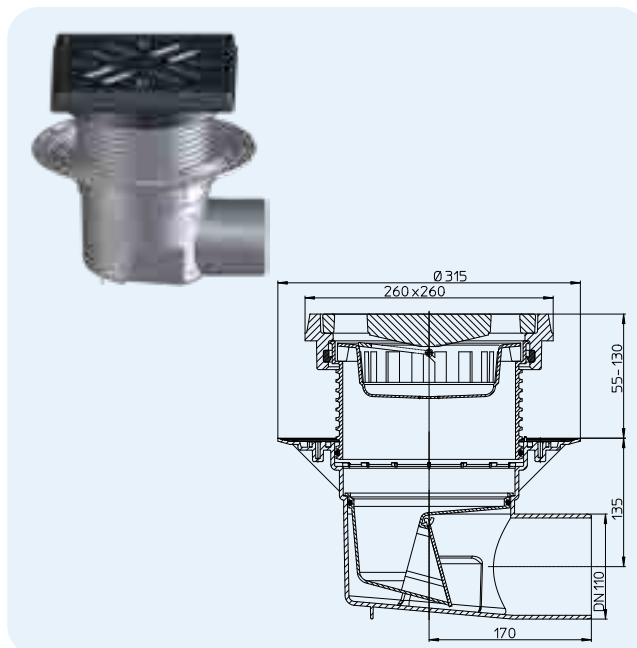

Capacity table HL615, HL615.1, HL615H, HL615.1H

Tested acc. to EN 1253-2:2015 acc. to pt. 5.5.2.1 Fig. 10a) + 10b) and pt. 5.5.1.2 Fig. 9

Drainage capacity measured according to EN 1253-2:2015 according to pt. 5.5.2.1 on downpipe 3 m

Nominal width	EN 1253	5 mm	15 mm	25 mm	35 mm	45 mm	55 mm	65 mm	75 mm
DN 110 horizontal	min. 4,5 (35 mm)	0,80	2,35	4,40	6,70	6,90	6,95	7,10	7,20

Drainage capacity measured according to EN 1253-2:2015 according to clause 5.5.1.2 free draining

Nominal width	EN 1253	5 mm	15 mm	20 mm	35 mm	45 mm	55 mm	65 mm	75 mm
DN 110 horizontal	min. 1,4 (20 mm)	0,85	2,70	3,45	5,35	5,55	5,65	5,80	5,90

HL-No.	Dimension	Weight	Stench trap	Grate	EAN	Piece/package
615.1	DN110	12400 g	Frost-proof flap	Cast iron	+006762	1
615.1W	DN110	12330 g	Water trap	Cast iron	+011278	1

HL615H Major drain PERFECT with bitumen flange and plastic frame, two-piece

Data

Material	PP
Grate	226 x 226 mm HL615H, HL615HW: Cast iron HL615HL, HL615HLW: Plastic HL615HS, HL615HSW: Stainless steel
Stench trap	HL615H, HL615HL, HL615HS: Frost-proof flap HL615HW, HL615HLW, HL615HSW: Water trap
Standard	EN 1253
Recommended for	Bitumen waterproofings
Load classification	A – max. 1,5 t L – max. 1,5 t
Additional information	Recess dimension min. 290 x 380 mm Heating set HL609 for heating of the drain body available
Including	Lid cover

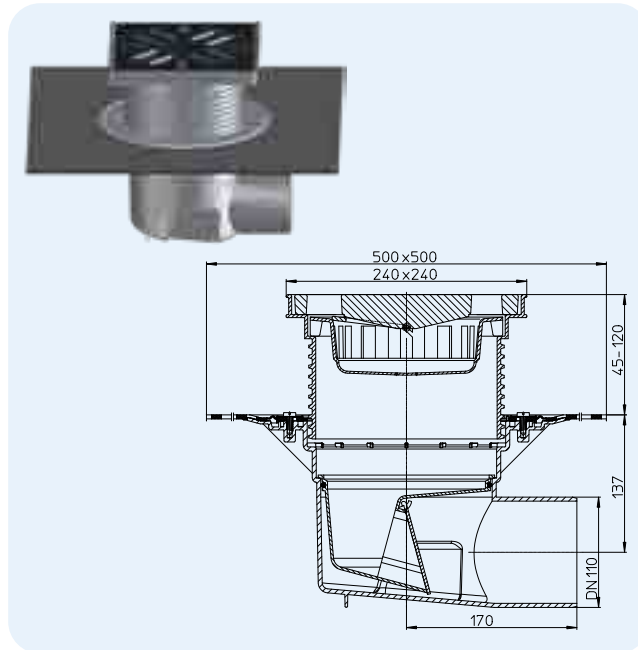

HL-No.	Dimension	Weight	Stench trap	Grate	EAN	Piece/package
615H	DN110	8345 g	Frost-proof flap	Cast iron	+006786	1
615HL	DN110	3175 g	Frost-proof flap	Plastic	+009497	1
615HS	DN110	4470 g	Frost-proof flap	Stainless steel	+011018	1
615HW	DN110	8700 g	Water trap	Cast iron	+011445	1
615HLW	DN110	3175 g	Water trap	Plastic	+009510	1
615HSW	DN110	4470 g	Water trap	Stainless steel	+011490	1

HL615.1H Major drain PERFECT with bitumen flange, cast iron frame and cast iron grate, two-piece

Data

Material	PP
Grate	Cast ironrost 226 x 226 mm Cast iron frame 260 x 260 mm
Stench trap	HL615.1H: Frost-proof flap HL615.1HW: Water trap
Standard	EN 1253
Recommended for	Bitumen waterproofings
Load classification	B – max. 12,5 t
Additional information	Recess dimension min. 290 x 380 mm Heating set HL609 for heating of the drain body available
Including	Lid cover

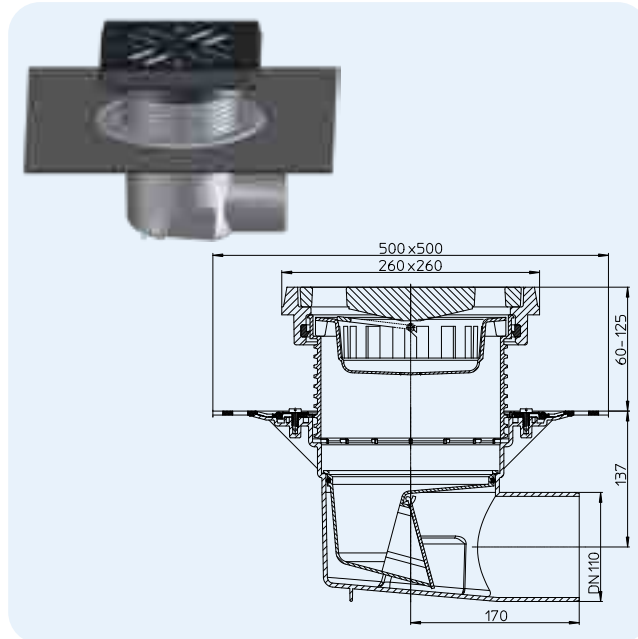

Capacity table HL615, HL615.1, HL615H, HL615.1H

Tested acc. to EN 1253-2:2015 acc. to pt. 5.5.2.1 Fig. 10a) + 10b) and pt. 5.5.1.2 Fig. 9

Drainage capacity measured according to EN 1253-2:2015 according to pt. 5.5.2.1 on downpipe 3 m

Nominal width	EN 1253	5 mm	15 mm	25 mm	35 mm	45 mm	55 mm	65 mm	75 mm
DN 110 horizontal	min. 4,5 (35 mm)	0,80	2,35	4,40	6,70	6,90	6,95	7,10	7,20

Drainage capacity measured according to EN 1253-2:2015 according to clause 5.5.1.2 free draining

Nominal width	EN 1253	5 mm	15 mm	20 mm	35 mm	45 mm	55 mm	65 mm	75 mm
DN 110 horizontal	min. 1,4 (20 mm)	0,85	2,70	3,45	5,35	5,55	5,65	5,80	5,90

HL-No.	Dimension	Weight	Stench trap	Grate	EAN	Piece/package
615.1H	DN110	13600 g	Frost-proof flap	Cast iron	+006809	1
615.1HW	DN110	13575 g	Water trap	Cast iron	+011476	1

HL616 Major drain PERFECT with flange and plastic frame, two piece

Data

Material	PP
Grate	226 x 226 mm HL616/1, HL616/5, HL616W/1, HL616W/5: Cast iron HL616L/1, HL616L/5, HL616LW/1, HL616LW/5: Plastic HL616S/1, HL616S/5, HL616SW/1, HL616SW/5: Stainless steel
Stench trap	HL616/1, HL616L/1, HL616S/1, HL616/5, HL616L/5, HL616S/5: Frost-proof flap HL616W/1, HL606LW/1, HL616SW/1, HL616W/5, HL616LW/5, HL616SW/5: Water trap
Standard	EN 1253
Load classification	A – max. 1,5 t L – max. 1,5 t
Additional information	Recess dimension min. 290 x 290 mm. Tap hole diameter: 250 mm. Heating set HL609 for heating of the drain body available
Including	Lid cover

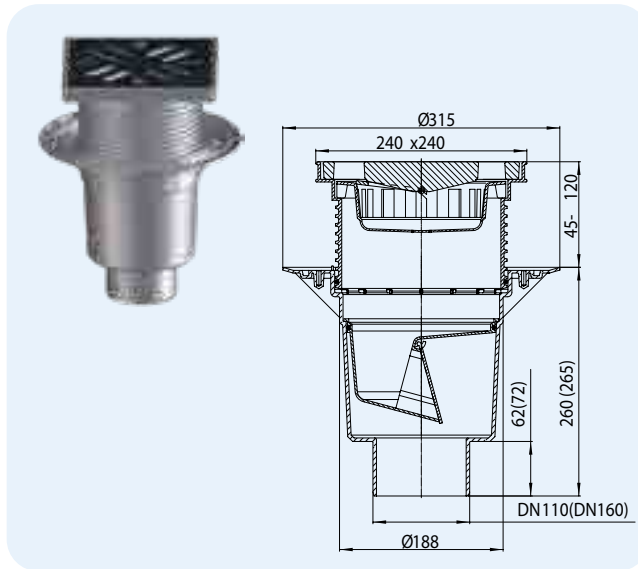

HL-No.	Dimension	Weight	Stench trap	Grate	EAN	Piece/package
616/1	DN110	8345 g	Frost-proof flap	Cast iron	+906161	1
616/5	DN160	8400 g	Frost-proof flap	Cast iron	+976164	1
616L/1	DN110	1860 g	Frost-proof flap	Plastic	+009534	1
616L/5	DN160	1865 g	Frost-proof flap	Plastic	+009558	1
616S/1	DN110	3155 g	Frost-proof flap	Stainless steel	+010967	1
616S/5	DN160	3160 g	Frost-proof flap	Stainless steel	+010981	1
616W/1	DN110	7380 g	Water trap	Cast iron	+011315	1
616W/5	DN160	7390 g	Water trap	Cast iron	+011339	1
616LW/1	DN110	1860 g	Water trap	Plastic	+009596	1
616LW/5	DN160	1870 g	Water trap	Plastic	+009572	1
616SW/1	DN110	3155 g	Water trap	Stainless steel	+011407	1
616SW/5	DN160	3165 g	Water trap	Stainless steel	+011421	1

HL616.1 Major drain PERFECT with flange, cast iron frame and cast iron grate, two-piece

Data

Material	PP
Grate	Cast iron 226 x 226 mm Cast iron frame 260 x 260 mm
Stench trap	HL616.1/1, HL616.1/5: Frost-proof flap HL616.1W/1, HL616.1W/5: Water trap
Standard	EN 1253
Load classification	B – max. 12,5 t
Additional information	Recess dimension min. 290 x 290 mm. Tap hole diameter: 250 mm. Heating set HL609 for heating of the drain body available
Including	Lid cover

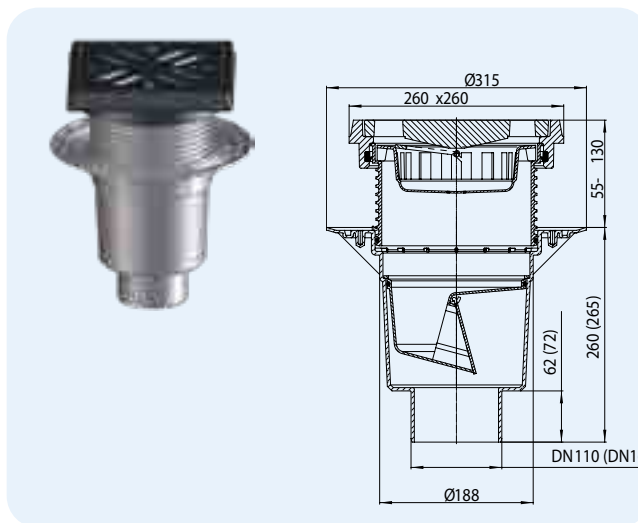

Capacity table HL616, HL616.1, HL 616H, HL616.1H

Tested acc. to EN 1253-2:2015 acc. to pt. 5.5.2.1 Fig. 10(a) + 10(b) and pt. 5.5.1.2 Fig. 9
Drainage capacity measured according to EN 1253-2:2015 according to pt. 5.5.2.1 on downpipe 3 m

Nominal width	EN 1253	5 mm	15 mm	25 mm	35 mm	45 mm	55 mm	65 mm	75 mm
DN 110 vertical	min. 4,5 (35 mm)	0,70	2,15	4,55	5,90	6,05	6,15	6,20	6,25
DN 160 vertical	min. 8,1 (35 mm)	0,95	2,65	5,30	7,65	7,75	8,00	8,10	-

Drainage capacity measured according to EN 1253-2:2015 according to clause 5.5.1.2 free draining

Nominal width	EN 1253	5 mm	15 mm	20 mm	35 mm	45 mm	55 mm	65 mm	75 mm
DN 110 vertical	min. 1,4 (20 mm)	0,45	2,40	3,40	6,10	6,20	6,30	6,35	6,40
DN 160 vertical	min. 4 (20 mm)	0,45	2,05	3,10	5,35	5,55	5,70	5,80	5,90

HL-No.	Dimension	Weight	Stench trap	Grate	EAN	Piece/package
616.1/1	DN110	12910 g	Frost-proof flap	Cast iron	+961610	1
616.1/5	DN160	13190 g	Frost-proof flap	Cast iron	+971619	1
616.1W/1	DN110	13430 g	Water trap	Cast iron	+011360	1
616.1W/5	DN160	13440 g	Water trap	Cast iron	+011384	1

HL616H Major drain PERFECT with bitumen flange and plastic frame, two-piece

Data

Material	PP
Grate	226 x 226 mm HL616H/1, HL616H/5, HL616HW/1, HL616HW/5: Cast iron HL616HL/1, HL616HL/5, HL616HLW/1, HL616HLW/5: Plastic HL616HS/1, HL616HS/5, HL616HSW/1, HL616HSW/5: Stainless steel
Stench trap	HL616H/1, HL616HL/1, HL616HS/1, HL616H/5, HL616HL/5, HL616HS/5: Frost-proof flap HL616HW/1, HL606HLW/1, HL616HSW/1, HL616HW/5, HL616HLW/5, HL616HSW/5: Water trap
Standard	EN 1253
Load classification	A – max. 1,5 t L – max. 1,5 t
Additional information	Recommended for Bitumen waterproofings; Recess dimension min. 290 x 290 mm. Tap hole diameter: 250 mm. Heating set HL609 for heating of the drain body available
Including	Lid cover

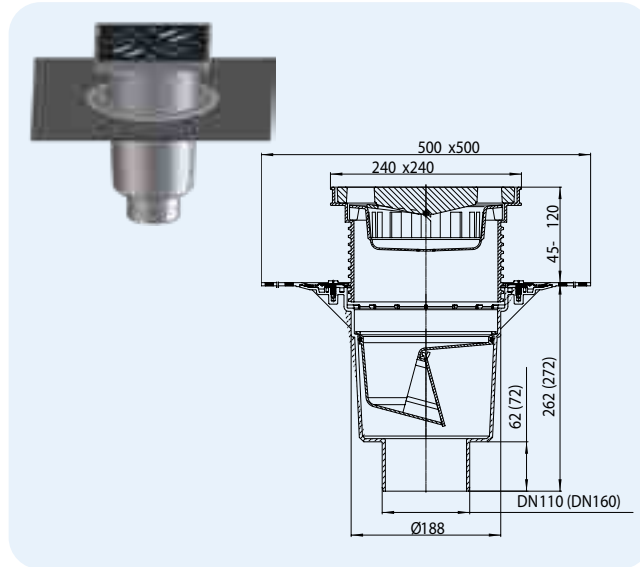

HL-No.	Dimension	Weight	Stench trap	Grate	EAN	Piece/package
616H/1	DN110	8900 g	Frost-proof flap	Cast iron	+916160	1
616H/5	DN160	9635 g	Frost-proof flap	Cast iron	+917167	1
616HL/1	DN110	3115 g	Frost-proof flap	Plastic	+009619	1
616HL/5	DN160	3120 g	Frost-proof flap	Plastic	+009633	1
616HS/1	DN110	4410 g	Frost-proof flap	Stainless steel	+011032	1
616HS/5	DN160	4415 g	Frost-proof flap	Stainless steel	+011056	1
616HW/1	DN110	8635 g	Water trap	Cast iron	+011513	1
616HW/5	DN160	8645 g	Water trap	Cast iron	+011537	1
616HLW/1	DN110	3115 g	Water trap	Plastic	+009671	1
616HLW/5	DN160	3125 g	Water trap	Plastic	+009657	1
616HSW/1	DN110	4410 g	Water trap	Stainless steel	+011599	1
616HSW/5	DN160	4420 g	Water trap	Stainless steel	+011629	1

HL616.1H Major drain PERFECT with bitumen flange and cast iron frame and grate

Data

Material	PP
Grate	Cast iron 226 x 226 mm Cast iron frame 260 x 260 mm
Stench trap	HL616.1H/1, HL616.1H/5: Frost-proof flap HL616.1HW/1, HL616.1HW/5: Water trap
Standard	EN 1253
Load classification	B – max. 12,5 t
Additional information	Recommended for Bitumen waterproofings Recess dimension min. 290 x 290 mm. Tap hole diameter: 250 mm. Heating set HL609 for heating of the drain body available
Including	Lid cover

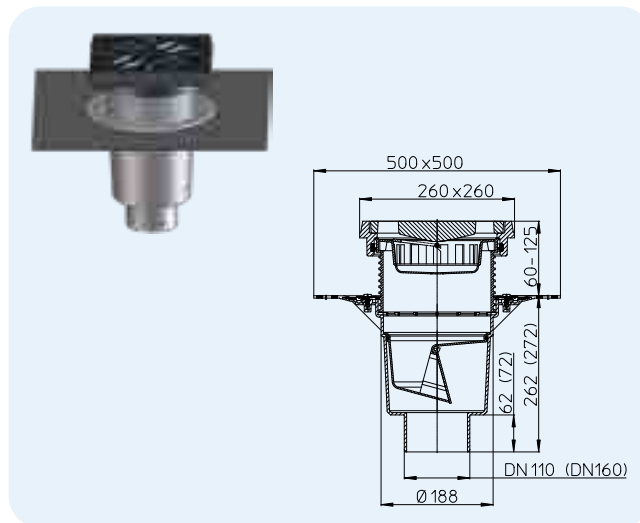

Capacity table HL616, HL616.1, HL 616H, HL616.1H
Tested acc. to EN 1253-2:2015 acc. to pt. 5.5.2.1 Fig. 10a) + 10b) and pt. 5.5.1.2 Fig. 9
Drainage capacity measured according to EN 1253-2:2015 according to pt. 5.5.2.1 on downpipe 3 m

Nominal width	EN 1253	5mm	15mm	25mm	35mm	45mm	55mm	65mm	75mm
DN 110 vertical	min. 4,5 (35 mm)	0,70	2,15	4,55	5,90	6,05	6,15	6,20	6,25
DN 160 vertical	min. 8,1 (35 mm)	0,95	2,65	5,30	7,65	7,75	8,00	8,10	-

Drainage capacity measured according to EN 1253-2:2015 according to clause 5.5.1.2 free draining

Nominal width	EN 1253	5mm	15mm	20mm	35mm	45mm	55mm	65mm	75mm
DN 110 vertical	min. 1,4 (20 mm)	0,45	2,40	3,40	6,10	6,20	6,30	6,35	6,40
DN 160 vertical	min. 4 (20 mm)	0,45	2,05	3,10	5,35	5,55	5,70	5,80	5,90

HL-No.	Dimension	Weight	Stench trap	Grate	EAN	Piece/package
616.1H/1	DN110	14240 g	Frost-proof flap	Cast iron	+962617	1
616.1H/5	DN160	14630 g	Frost-proof flap	Cast iron	+951611	1
616.1HW/1	DN110	13520 g	Water trap	Cast iron	+011551	1
616.1HW/5	DN160	13530 g	Water trap	Cast iron	+011575	1

HL Major drains – Accessories – Data

HL621 Extension with plastic frame and cast iron grate

Data

Material	PP
Frame	Plastic 240 x 240 mm
Grate	Cast iron 226 x 226 mm
Load classification	A – max. 1,5 t L – max. 1,5 t
Additional information	fits to all major drains

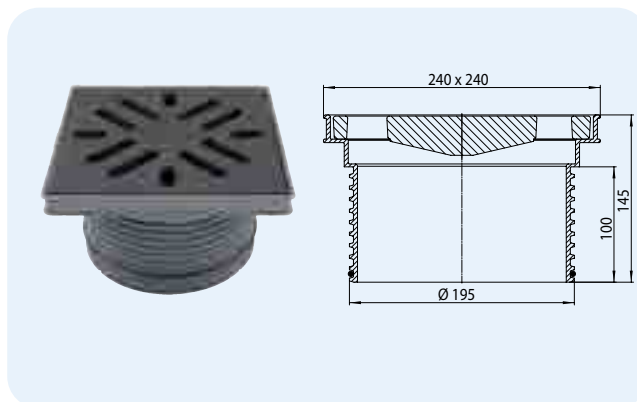

Cast iron

HL0606.1E

HL608



HL01056D

HL-No.	Weight	EAN	Piece/package
621	6510 g	+014644	1

HL622, (HL622/S) Extension with plastic frame and screwable stainless steel grate (V4A)

Data

Material	PP, Stainless steel
Frame	Plastic 240 x 240 mm
Grate	HL622: Stainless steel 226 x 226 mm HL622/S: Stainless steel 226 x 226 mm V4A
Load classification	A – max. 1,5 t
Additional information	fits to all major drains

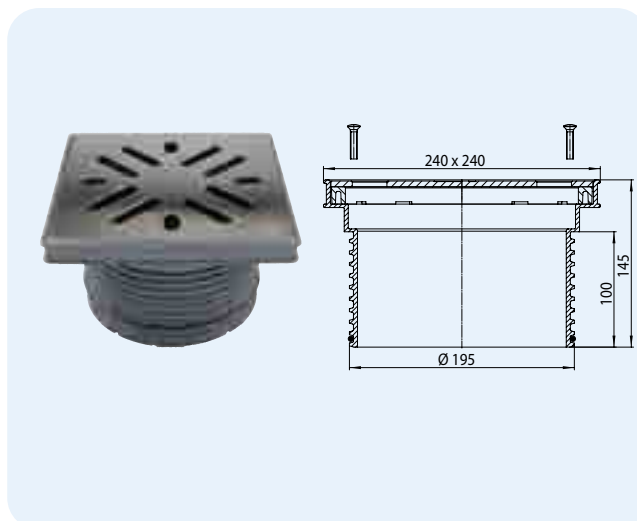

HL0605.3E



HL0605.5E

HL608



HL01056D

HL-No.	Weight	EAN	Piece/package
622	2220 g	+014705	1
622/S	2220 g	+014729	1

HL623 Extension with plastic frame and screwable plastic grate

Data

Material	PP, Plastic
Frame	Plastic 240 x 240 mm
Grate	Plastic 226 x 226 mm
Load classification	A – max. 1,5 t
Additional information	fits to all major drains

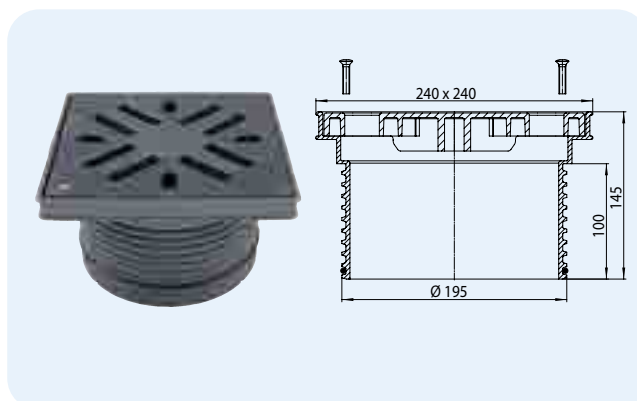

HL0605.1E



HL0605.5E

HL608



HL01056D

HL-No.	Weight	EAN	Piece/package
623	954 g	+014743	1

HL624, (HL624V) Extension with cast iron frame and cast iron grate (screwable)

Data

Material	PP, Cast iron
Frame	Cast iron 260 x 260 mm
Grate	HL624: Cast iron 226 x 226 mm HL624V: Cast iron 226 x 226 mm screwable
Load classification	B – max. 12,5 t
Additional information	fits to all major drains

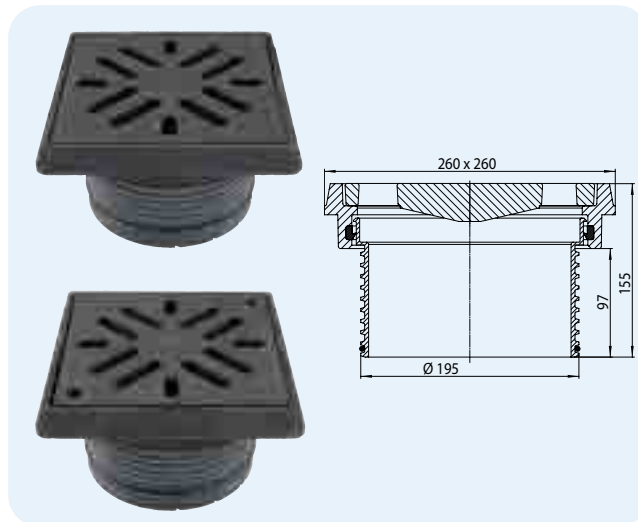

HL-No.	Weight	EAN	Piece/package
624	11370 g	+014767	1
624/V	11370 g	+028597	1

HL190 Gravel guard

Data

Material	PP
Additional information	for the installation between flange of the body and extension, to guarantee enough drainage on the sealing level, e.g. with inverted constructions, fits to all major drains

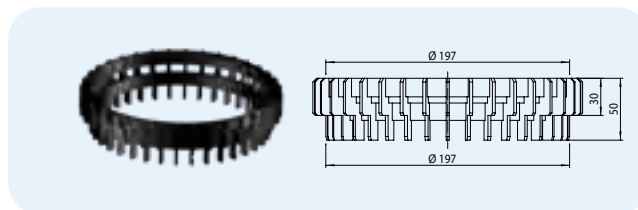

HL-No.	Dimension	Weight	EAN	Piece/package
190	Ø 197 mm	95 g	+011858	1

HL191 Gravel trap

Data

Material	PP
Additional information	flat gravel trap for usage below flaged floors or duckboards

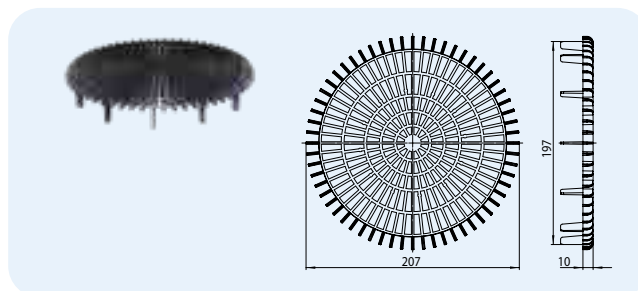

HL-No.	Dimension	Weight	EAN	Piece/package
191	Ø 197 mm	120 g	+029006	1

HL195 Leaf catcher

Data

Material	PP
Additional information	for non-walkable surfaces, fits to all major drains

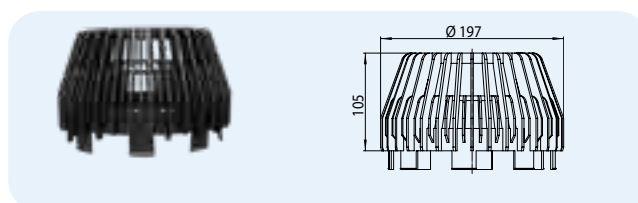

HL-No.	Dimension	Weight	EAN	Piece/package
195	Ø 197 mm	250 g	+018093	1

HL609 Heating Set

Data

Additional information self-regulating heating tape (2m length) with 18W/m, equal to 36W/230V. Including a 3-pole kable (length 1 m), self-adhesive thermal conducting tape and insulation tape. Overheating is, due to the self-regulating construction, impossible. Fits to all major drains.

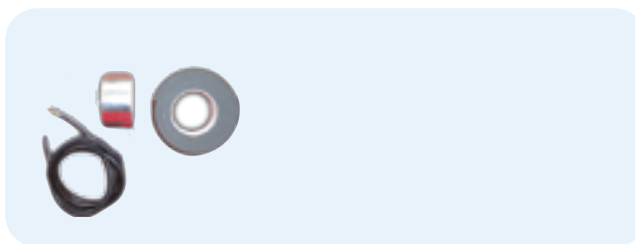

HL-No.	Weight	EAN	Piece/package
609	704 g	+006090	1

HL619 Fixing brackets „FixIt“

Data

Material Stainless steel
 Additional information For a tensile-safe connection between drain body and extension

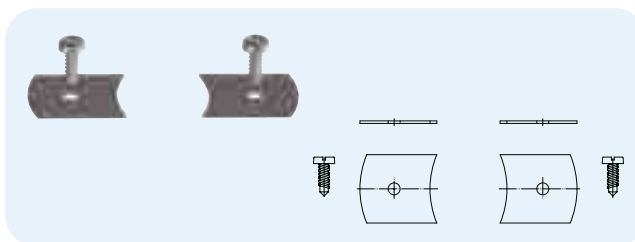

HL-No.	Weight	EAN	Piece/package
619	54 g	+013197	1



SIPHONS ABLÄUFE



DN40 = 80-315

DN32 = 80-315

29



DN40 = 350
DN32 = 350

DN40 = 280

DN32 = 285



DN40

DN32



DN40 = 95
DN32 = 90



HL Anti-flooding valves

DN40 = 50-225
DN32 = 50-220

16. Basement and backflooding

16



HL Anti-flooding valves

Basic information about design and installation

Already during the design of drainage systems in buildings one should consider the issue „backflooding“. To simplify the professional installation of anti-flooding valves, we would like to point out the following topics.

▲ What does the term „flood level“ mean?

Flood level means the highest level, up to which backwater from the sewer could rise inside the building, according to the standard. In fact, this is (if not regulated by the authority) 15 cm above the street level or the pavement. Up to this level, it is possible to be save against backwater by using anti-flooding valves. Outlets and traps, which are above this level, are anyway secure against backflowing water from the sewer.

▲ Which drains have to be save against backwater?

Only drains, which are situated below the flood level, may be leaded through standardized anti-flooding valves. The reason is, that in case of backwater from the sewer, drains above the flood level still can be used. Please notice, that floors above the flood level should not be lead throught the anti-flooding valve. There is danger, that the basement is flooded by the sewage from the rest of the building (see picture below).

▲ When is it possible, to install an antiflooding valve?

- When there is a natural incline to the canalization
- When the rooms are used of subordinated use, which means, that no persons or material assets may be injured.
- When there is little usage and an additional toilet above the backflow level.
- When there is an access for inspection/maintainence

▲ Maintenance

According to the standard maintainance and function test have to be made every half year.

▲ Classification acc. standard, see selection criteria

▲ Mechanical or electronic anti-flooding valve for waste water, containing faeces?

- Electronic anti-flooding valve:

Advantage: Faeces are not blocked by a closed flap, as the valve stays open during normal waste water flow. According to standard ÖNORM B2501, ÖNORM EN 13546 and EN12056-4

Disadvantage: High price of electronic valves due to an elaborated design, expensive installation (electrician!) and complicated maintenance.

- Double mechanical anti-flooding valve:

Advantage: Simple installation, low costs, resilient design, little maintenance (made by the house owner itself). Beside of that the stainless steel flap provides a perfect protection against rats.

Only according to standard ÖNORM B2501, ÖNORM EN13564 and EN12056-4

Image of a drainage system

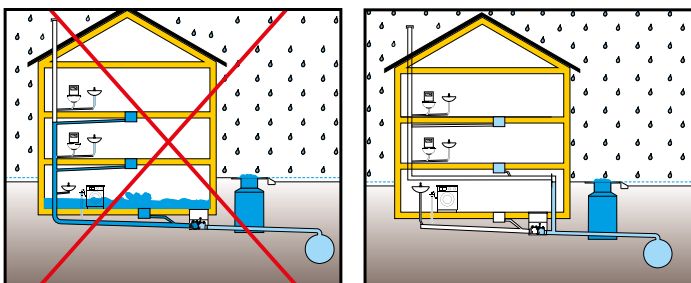

Relevant standards/directives

- ÖNORM B2501 Drainage of buildings
- ÖNORM EN12056-1 ...Gravity drainage systems inside of buildings
- ÖNORM EN752Gravity drainage systems outside of buildings
- DIN EN1986-100 Drainage systems for buildings and estates
- DIN EN1986-3 Drainage of buildings ... (function)
- DIN EN1986-30 Drainage of buildings ... (maintainence)
- ÖNORM EN13564 Anti-flooding valves for buildings

Selection of the convenient valve acc. ÖNORM EN13564-1



Typ 0: Anti-flooding valve with one self-acting closure.
HL710, HL712, HL715, HL720



Typ 1: Anti-flooding valve for horizontal pipes with one self-acting closure and one emergency closure. The emergency closure may be combined with the self-acting closure.
HL710.1, HL712.1, HL715.1, HL720.1



Typ 2: Anti-flooding valve with two self-acting closures and emergency closure. The emergency closure may be combined with the self-acting closure.
HL710.2, HL712.2, HL715.2, HL720.2



Typ 3: Anti-flooding valve with a self-acting closure, which is operated by external power (electric, pneumatic or others) and emergency closure, which is independent from the self-acting closure.
HL710.2EPC, HL712.2EPC, HL715.2EPC



Typ 5: Anti-flooding valve, which is included in drainage sets or floor drains, with two self-acting closures and emergency closure. The emergency closure may be combined with the self-acting closure.
HL77, HL77.1

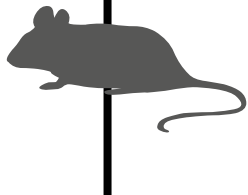

The prevention from backwater is one of the most sophisticated challenges of plumbing. HL cares for this task with its series of mature products. HL anti-flooding valves are designed according to all standards of drainage technology. Beside of that they are equipped with components made of stainless steel. This measure protects from the invasion of uninvited guests like rats, proved by a lab test of the medical university of Vienna.

During the lab test, the rats were not able to pass the stainless steel valve. HL anti-flooding valves are seen as a suitable instrument, to protect buildings from the invasion of rodents.



HL Anti-flooding valves – Products – Overview

Anti-flooding valves



Product	HL710.1V	HL710 – HL720	HL710.1 – HL720.1
Description	Vertical anti-flooding valve with manual closure	Anti-flooding valve without manual closure	Anti-flooding valve with manual closure
Function	Only for vertical installation!	acc. EN 13564 type 0	acc. EN 13564 type 1

Drains



Product	HL70	HL71	HL72(N)	HL73(Pr).(0).(2)
Description	Floor drain horizontal with 3 side inlets	Basement drain with mud bucket	Basement drain with gravel catcher	Plug-in drain
Function	Backflow protected, with 3 inlet possibilities	For the drainage of floor surfaces, high capacity	For the drainage of floor surfaces	Fits for pipes DN110 (straight end, non socket)

HL Anti-flooding valves – Products – Overview

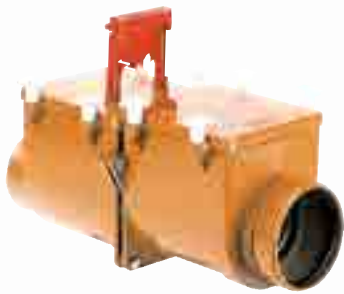

HL710.2 – HL720.2

Double anti-flooding valve with manual closure

Corresponds to type 2 (acc. EN 13564); for upgrade to type 3 use upgrade kit HL0710E.X or HL0715E.X

HL710.2EPC – HL715.2EPC

Anti-flooding valve with electronic valve and manual closure

acc. EN 13564 type 3

HL710.0 – HL720.0

Single anti-flooding valves

At the end of drainage pipes (e.g. in shafts), according EN 13564 - type 0



HL77, HL77.1

Basement drain with triple backwater valve

Usage below the flood level, according EN13546 - type 5

HL4

Backwater protector

Usage above the flood level!

HL Anti-flooding valves – Products – Data

HL710 – 720 Anti-flooding valve with stainless steel flap and cleaning access

Data

Material	ABS
Inlet	DN110, DN125, DN160, DN200
Outlet	horizontal
Standard	According EN 13564 type 0
Recommended for	Plastic pipes with socket
Additional information	Self-acting stainless steel flap and cleaning access
Spare parts	see www.hl.at

HL-No.	Dimension	Weight	EAN	Piece/ package
710	DN110	2020 g	+907106	1
712	DN125	2090 g	+907120	1
715	DN160	3760 g	+907151	1
720	DN200	4060 g	+907205	1

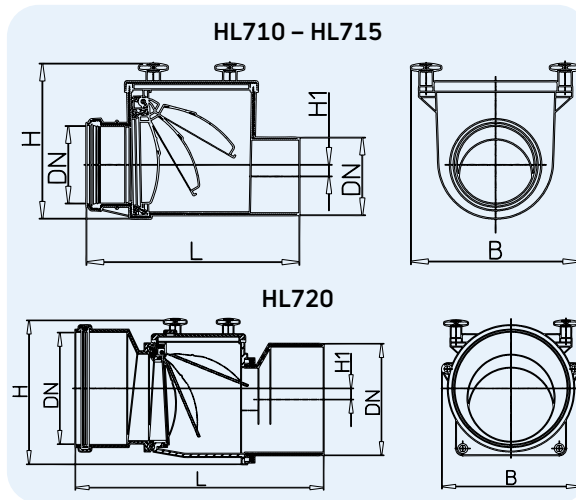

	DN	H	B	L	H1
HL710	110	222	240	302	16,5
HL712	125	222	240	315	16,5
HL715	160	246	274	376	11,5
HL720	200	260	258	445	20

Dimensions in mm

HL710.1 – 720.1 Anti-flooding valve with stainless steel flap, manual closure and cleaning access

Data

Material	ABS
Inlet	DN110, DN125, DN160, DN200
Outlet	horizontal
Standard	According EN 13564 type 1
Recommended for	Plastic pipes with socket
Additional information	Self-acting stainless steel flap and cleaning access, additional manual closure and cleaning access
Spare parts	see www.hl.at

HL-No.	Dimension	Weight	EAN	Piece/ package
710.1	DN110	2180 g	+971015	1
712.1	DN125	2235 g	+971213	1
715.1	DN160	3380 g	+971510	1
720.1	DN200	3680 g	+972012	1

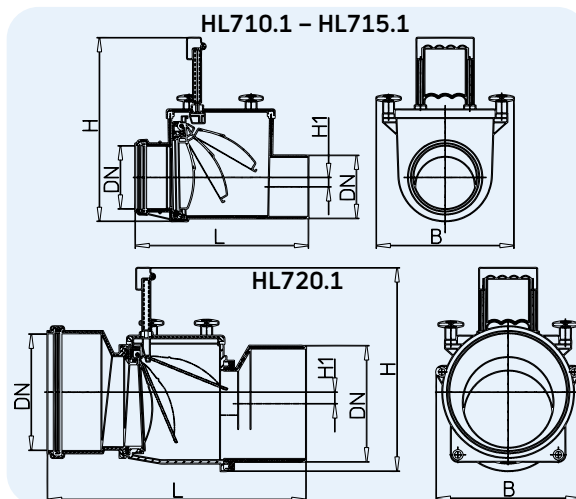

	DN	H	B	L	H1
HL710.1	110	220-320	240	302	16,5
HL712.1	125	220-320	240	315	16,5
HL715.1	160	266-356	274	376	11,5
HL720.1	200	248-348	258	445	20

Dimensions in mm

HL710.0 – 720.0 Single anti-flooding valve with stainless steel flap

Data

Material	ABS
Inlet	DN110, DN125, DN160, DN200
Outlet	horizontal
Standard	According EN 13564 type 0
Recommended for	Plastic pipes with socket
Additional information	Self-acting stainless steel flap and cleaning access
Spare parts	see www.hl.at

HL-No.	Dimension	Weight	EAN	Piece/ package
710.0	DN110	720 g	+971008	1
712.0	DN125	730 g	+971206	1
715.0	DN160	1325 g	+971503	1
720.0	DN200	1340 g	+172009	1

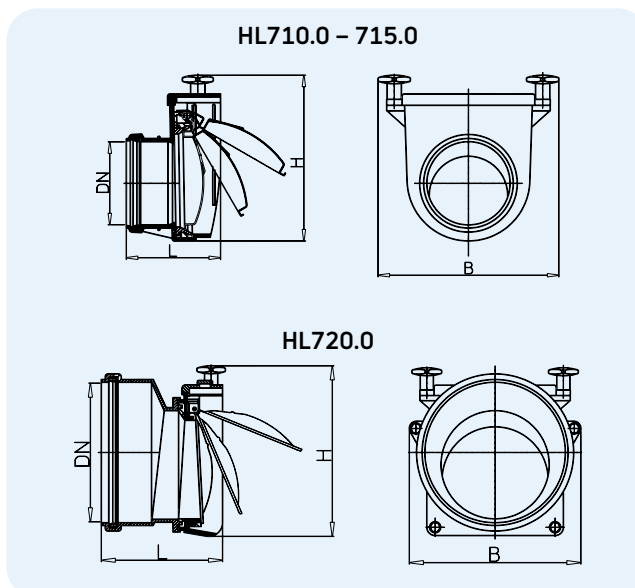

	DN	H	B	L
HL710.0	110	222	240	125
HL712.0	125	222	240	128
HL715.0	160	246	274	164
HL720.0	200	260	258	177

Dimensions in mm

HL710.2 – 720.2 Anti-flooding valve with 2 stainless steel flaps, manual closure and cleaning access
Data

Material	ABS
Inlet	DN110, DN125, DN160, DN200
Outlet	horizontal
Standard	According EN 13564 type 2
Recommended for	Plastic pipes with socket
Additional information	2 self-acting stainless steel flaps, manual closure, cleaning access, mechanical parts made of stainless steel, connection to test-pipe, body made of impact-resistant ABS with tommy screws for easy opening For upgrade to type 3 use upgrade kit HL0710E.X or HL0715E.X
Spare parts	see www.hl.at

HL-No.	Dimension	Weight	EAN	Piece/package
710.2	DN110	3230 g	+971022	1
712.2	DN125	3320 g	+971220	1
715.2	DN160	5870 g	+971527	1
720.2	DN200	6170 g	+972029	1

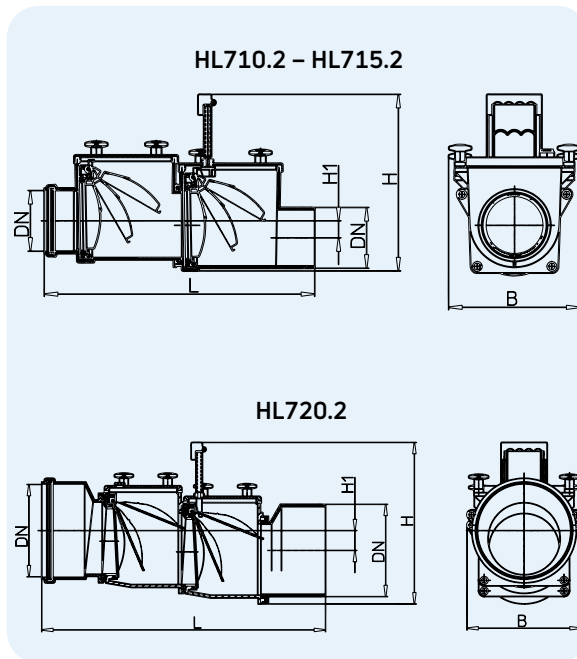

	DN	H	B	L	H1
HL710.2	110	220–320	240	490	31
HL712.2	125	220–320	240	503	31
HL715.2	160	266–356	274	590	23
HL720.2	200	248–348	258	615	40

Dimensions in mm

HL0710E.X Upgrade kit; for upgrading to electronic valve (type 3); DN110 + DN125
HL0715E.X Upgrade kit; for upgrading to electronic valve (type 3); DN150
Data

Material	ABS
Standard	Acc. EN 13564 type 3
Recommended for	upgrade from type 2 to type 3
Additional information	Optical display, optical and acoustic fault display in the control unit; additional PC interface
Power supply	230 V/0,5 A
Power supply line	6 m, PUR, 5 x 0,75 mm ²
Motor	12 V low voltage
Emergency supply	12 V Accu
Sensor	Coaxial electrode
Tight power	500 N
Closure time	appr. 11 seconds
Spare parts / Manual	see www.hl.at

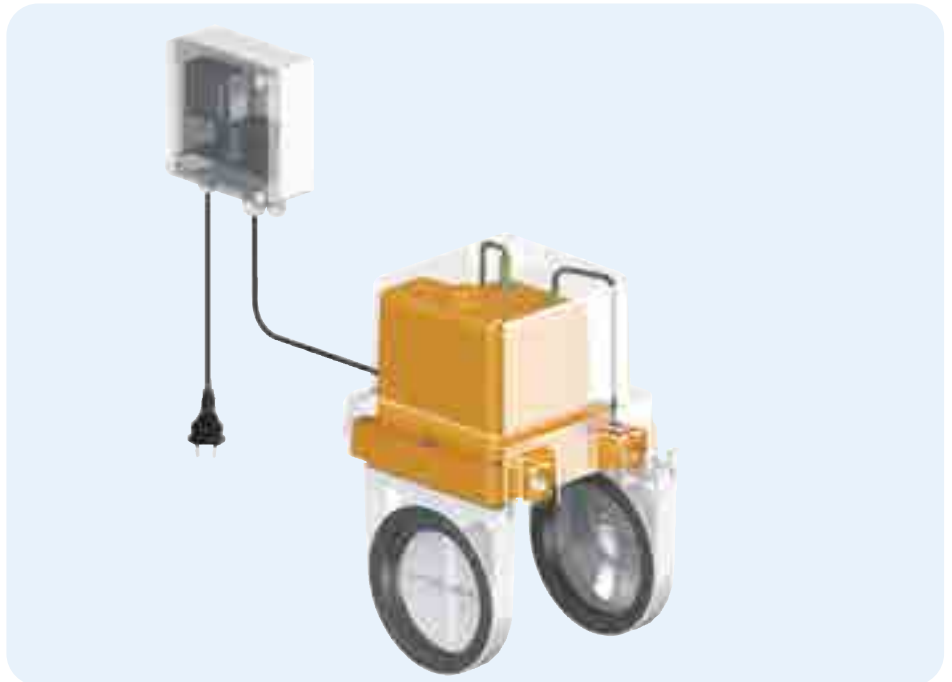

HL-No.	Fits to	Weight	EAN	Piece/package
0710E.X	HL710.2 + HL712.2	4300 g	+013364	1
0715E.X	HL715.2	4882 g	+013371	1

HL710.2EPC – 715.2EPC Anti-flooding valve with electronic operated flap

Data

Material	ABS
Inlet	DN110, DN125, DN160
Outlet	horizontal
Standard	According EN 13564 type 3
Recommended for	Plastic pipes with socket
Additional information	Optical display, optical and acoustic fault display in the control unit; additional PC interface
Anti-flooding valves	Stainless steel 1.4404/HDPE
Power supply	230 V/0,5 A
Power supply line from control unit to flap	6 m, PUR, 5 x 0,75 mm ²
Motor	12 V low voltage
Emergency supply	12 V Accu
Sensor	Coaxial electrode
Tight power	500 Newton
Closure time	appr. 11 seconds
Spare parts / Manual	see www.hl.at

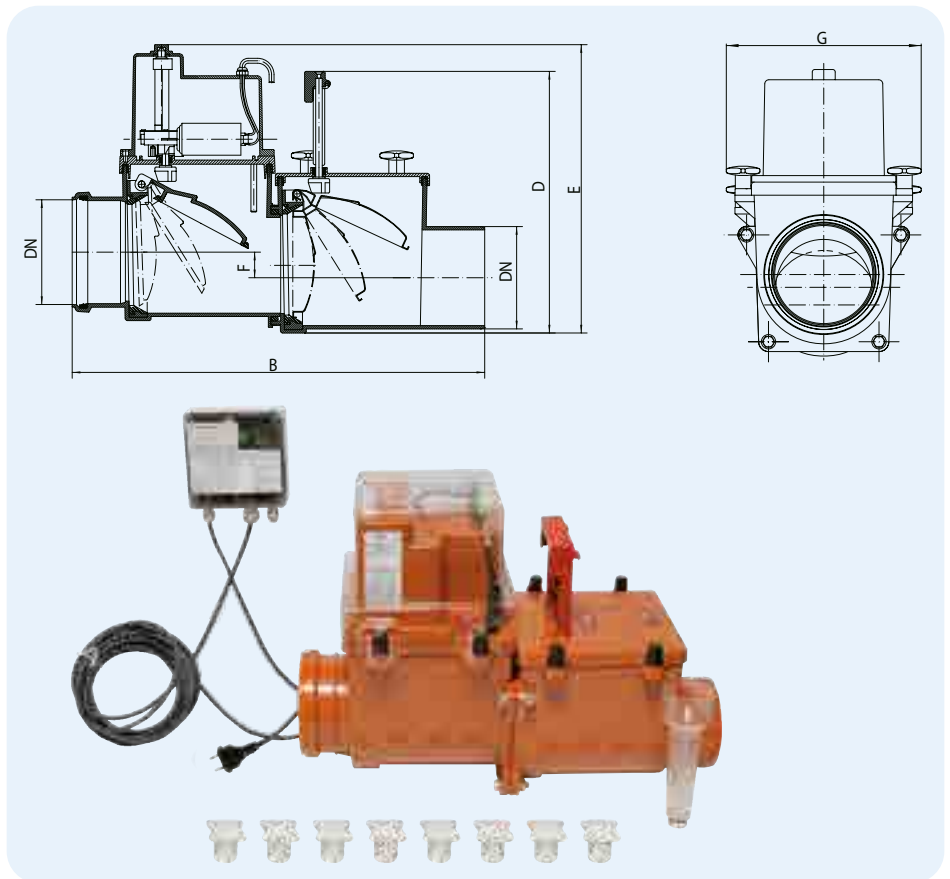

HL-No.	Dimension	Weight	EAN	Piece/package
710.2EPC	DN110	6600 g	+008469	1
712.2EPC	DN125	6189 g	+008483	1
715.2EPC	DN160	7973 g	+011643	1

	DN	B	D	G	E	F
HL710.2EPC	110	490	220-320	240	352	31
HL712.2EPC	125	503	220-320	240	352	31
HL715.2EPC	160	590	266-356	274	371	23

Dimensions in mm

HL710.1V Vertical anti-flooding valve with manual closure

Data

Material	ABS
Inlet	DN110
Outlet	vertical
Recommended for	Plastic pipes with socket; for vertical installation
Additional information	Automatically working stainless steel flap with integrated floating body, additional manual closure and cleaning access
Spare parts / Manual	see www.hl.at

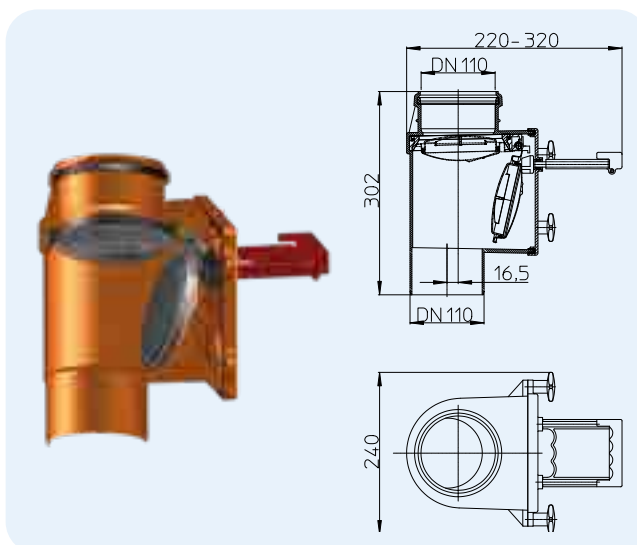

HL-No.	Dimension	Weight	EAN	Piece/package
710.1V	DN110	1970 g	+826216	1

HL70 Floor drain with backwater protector and 3 side inlets

Data

Capacity	1,12 l/s
Material	PE
Inlet	3 side inlets, DN50/40, pluggable and weldable
Outlet	DN75/110, horizontal, pluggable and weldable
Extension	123 x 123 mm
Stench trap	Water trap
Grate	Stainless steel 115 x 115 mm
Standard	According EN 13564 type 4
Load classification	K3 – max. 300 kg
Recommended for	Integration into a waterproofing is possible
Additional information	Self-acting backwater protector, may also be fixed manually

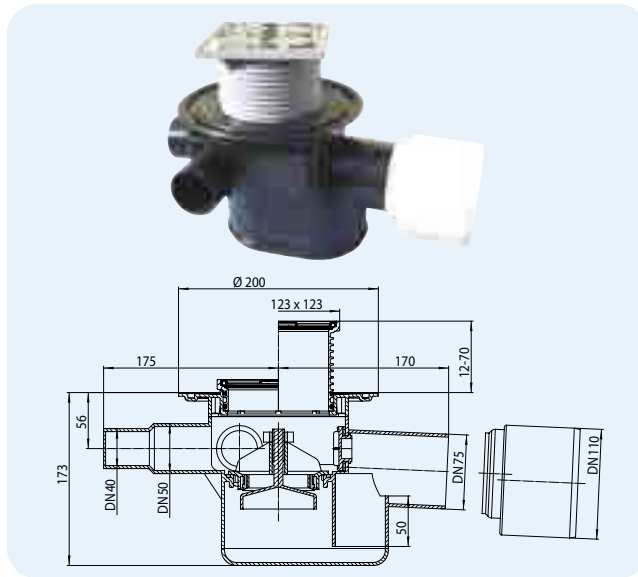

HL-No.	Dimension	Grate	Weight	EAN	Piece/package
70	DN75/110	Stainless steel 115 x 115 mm	1350 g	+700707	1
70G	DN75/110	Cast iron 150 x 150 mm	3250 g	+001941	1

HL71 Basement drain with plastic grate HL71G like HL71, but with cast iron grate

Data

Capacity	2,30 l/s
Material	HL71: ABS HL71G: ABS/Cast iron
Outlet	DN110, horizontal, pluggable
Extension	170 x 240 mm
Stench trap	Water trap with 60 mm height of seal water
Grate	HL71: ABS HL71G: Cast iron
Standard	ÖNORM B2511, EN 1253
Load classification	HL71: K3 – max. 300 kg HL71G: L15 – max. 1,5 t
Recommended for	Basement area
Additional information	Installation, where you don't have requirements for waterproofing. With mud bucket

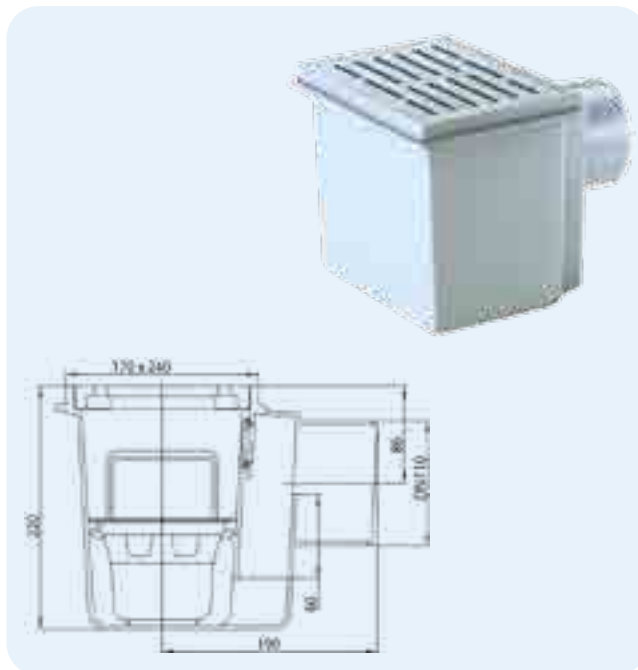

HL-No.	Dimension	Grate	Weight	EAN	Piece/package
71	DN110	Plastic	1400 g	+700714	1
71G	DN110	Cast iron	1550 g	+701711	1

HL71.1 Basement drain with side inlet DN50 or DN75

Data

Capacity	2,30 l/s
Material	ABS
Inlet	HL71.1/50: DN50 HL71.1/7: DN75
Outlet	DN110, horizontal, pluggable
Extension	170 x 240 mm
Stench trap	Water trap with 60 mm height of seal water
Grate	ABS
Standard	ÖNORM B2511, EN 1253
Load classification	K3 – max. 300 kg
Recommended for	Basement area
Additional information	Installation, where you don't have requirements for waterproofing. With mud bucket

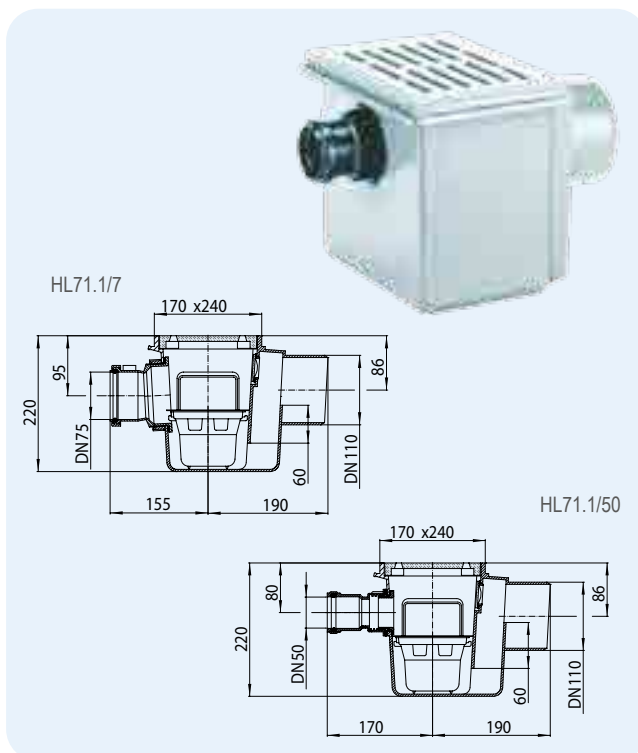

HL-No.	Dimension	Grate	Weight	EAN	Piece/package
71.1/50	DN110/50	Plastic	1430 g	+711505	1
71.1/7	DN110/75	Plastic	1660 g	+711703	1

HL72 Basement drain with plastic grate HL72N like HL72 but with stainless steel grate

Data

Capacity	HL72: 1,67 l/s HL72N: 1,67 l/s HL72N/7: 1,47 l/s
Material	PP / Stainless steel
Outlet	HL72 u. HL72N: DN110 HL72N/7: DN75
Extension	horizontal, pluggable
Stench trap	Water trap with 60 mm height of seal water
Grate	HL72: Plastic grate 138 x 138 mm HL72N u. HL72N/7: Stainless steel grate 138 x 138 mm
Standard	ÖNORM B2511, EN 1253
Load classification	K3 – max. 300 kg
Recommended for	Inside the building
Additional information	Installation, where you don't have requirements for waterproofing. With gravel catcher

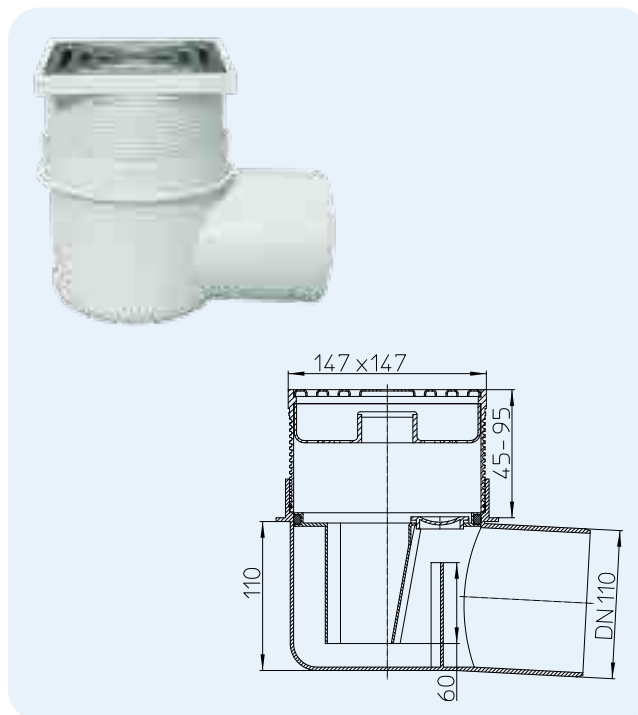

HL-No.	Dimension	Grate	Weight	EAN	Piece/package
72	DN110	Plastic	830 g	+700721	1
72N	DN110	Stainless steel	830 g	+999729	1
72N/7	DN75	Stainless steel	800 g	+013104	1

HL73(Pr).(0).(2) Plug-in drain DN110

Data

Capacity	HL73Pr: 0,46 l/s HL73.0: 1,1 l/s HL73.2: 0,8 l/s
Material	PP, stainless steel
Outlet	Fit into straight on of DN110 plastic pipe
Extension	121 x 121 mm
Stench trap	HL73Pr: PRIMUS trap (no stench, when it gets dry) HL73.0: Without trap HL73.2: With frostproof flap (use outside) stainless steel V4A
Grate	Stainless steel grate 115 x 115 mm stainless steel V2A
Load classification	K3 – max. 300 kg
Recommended for	HL73Pr: For not frequently used drains inside HL73.0: For rain water pipes HL73.2: For mixed sewer pipes outside
Additional information	To be used, when there is no waterproofing

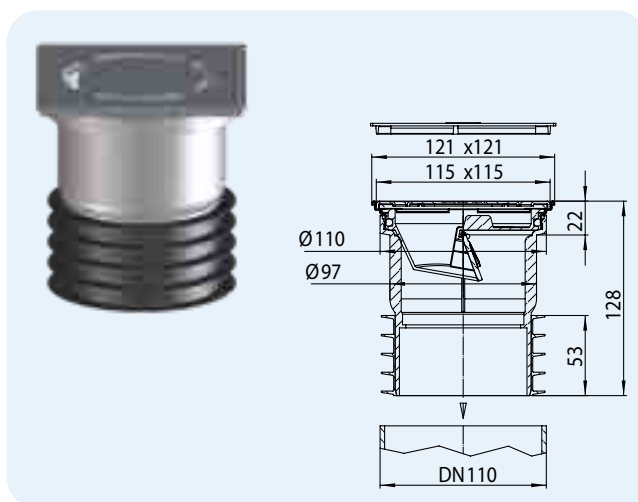

HL-No.	Dimension	Grate	Weight	EAN	Piece/package
73Pr	DN110	Stainless steel V2A	457 g	+032327	1
73.0	DN110	Stainless steel V2A	397 g	+034420	1
73.2	DN110	Stainless steel V2A	447 g	+034437	1

HL77 Basement drain with triple backwater protection

Data

Capacity	1,58 l/s
Material	ABS
Outlet	DN110, horizontal, pluggable
Stench trap	Water trap
Grate	ABS, two parts, 180 x 125 mm
Standard	According EN 13564 type 5
Load classification	K3 – max. 300 kg
Recommended for	Only for installation in frost-proof area!
Additional information	2 self-acting anti-flooding valves, manual closure, removable trap, connection to test pipe

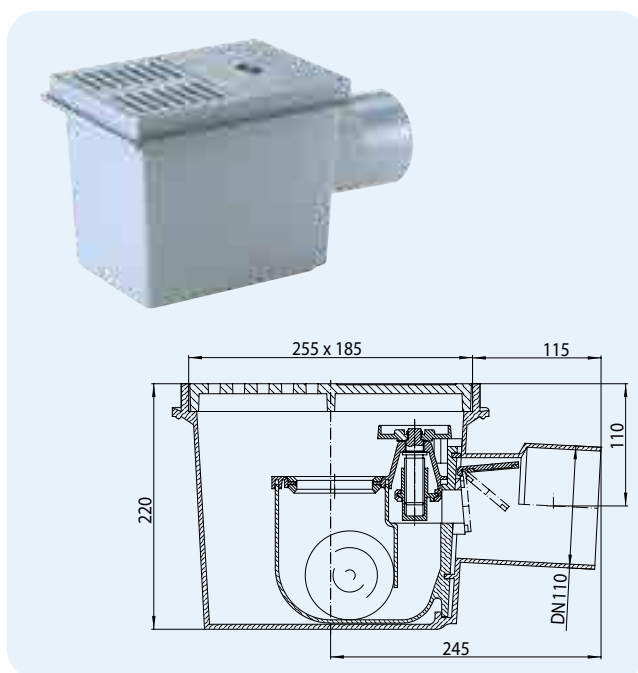

HL-No.	Dimension	Weight	EAN	Piece/package
77	DN110	3340 g	+700776	1

HL77.1 Basement drain like HL77, with side inlet DN50

Data

Capacity	1,58 l/s
Material	ABS
Inlet	DN50
Outlet	DN110, horizontal, pluggable
Stench trap	Water trap
Grate	ABS, two parts, 180 x 125 mm
Standard	According EN 13564 type 5
Load classification	K3 – max. 300 kg
Recommended for	Only for installation in frost-proof area!
Additional information	2 self-acting anti-flooding valves, manual closure, removable trap, connection to test pipe

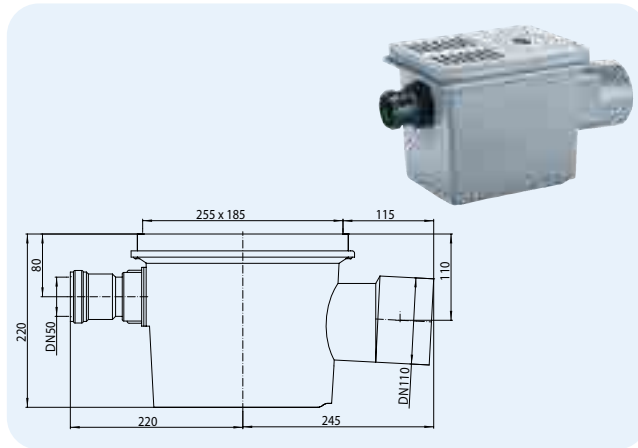

HL-No. 77.1	Dimension DN110	Weight 3550 g	EAN +710775	Piece/package 1
----------------	--------------------	------------------	----------------	--------------------

HL4 Backwater protector with cleaning screw DN50

Data

Capacity	1,36 l/s
Material	PP
Inlet	DN50
Recommended for	usage horizontal and vertical, only above flood level

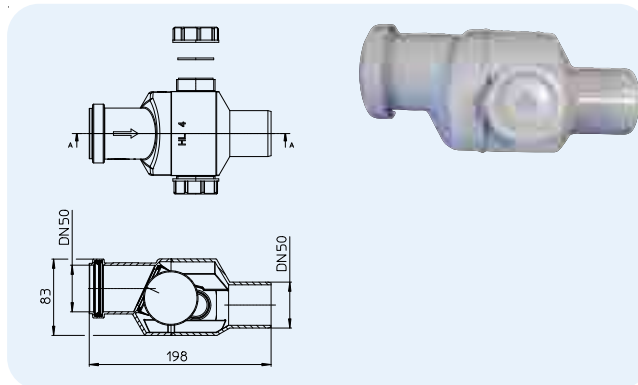

HL-No. 4	Dimension DN50	Weight 280 g	EAN +900046	Piece/package 1
-------------	-------------------	-----------------	----------------	--------------------

HL4/7 Backwater protector with cleaning screw DN75

Data

Capacity	2,30 l/s
Material	PP
Inlet	DN75
Recommended for	usage horizontal and vertical, only above flood level

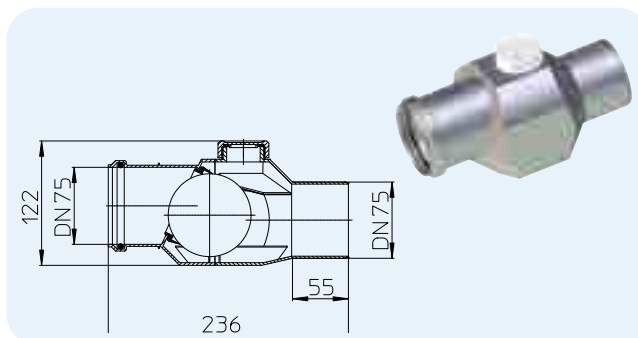

HL-No. 4/7	Dimension DN75	Weight 400 g	EAN +000661	Piece/package 1
---------------	-------------------	-----------------	----------------	--------------------



SIPHONS ABLÄUFE

327 x 164(185)

Ø 110/100/
90/75

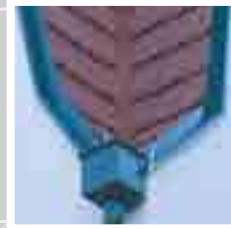

255

490

DN110
17

HL Rain hoppers

17. Rainwater drainage



HL Rain hoppers

Basic information about design and installation

The drainage of roof rainwater into the sewer or a soakaway belongs to today's normal standard of modern buildings. In the best case the connection between the downpipe and the sewage pipe is a rain hopper.

We have assembled some suggestions for you for perfect design and realization:

▲ Rainwater downpipes should have a possibility for cleaning, maintenance and inspection at the junction to the horizontal pipe.

▲ If rainwater downpipes are connected to the sewer, they have to be secured by a stench trap (in cold regions frostproof), when stench may be expected.

▲ The maximum roof surface, which may be drained, is calculated on the basis of the capacity of the downpipes acc. EN12056-3 and a minimum rainfall quantity of 300 l / (s x ha).

▲ Extract of ÖNORM B2501
Rainwater downpipes, which are installed on the outer side of the building, must be

connected to rain hoppers. The rain hoppers may be seen as the best cleaning access.

Relevant standards/directives

- ÖNorm B2501Drainage of buildings
- DIN 1986-100Drainage systems for buildings and estates
- EN 12056Gravity drainage systems inside of buildings

Drain capacity: 11 l/s: more than 50% higher capacity!



Cover and flap: with pre-formed gaskets - to reduce uprising of smell from the sewer



Connection of downpipe: possible up to diameter 120mm



Leaf catcher: Bigger and with overflow-function; if the basket is full of leaves, the middle pipe cares for a minimum drainage



Outlet: Connection DN110 and DN125 in one piece



New handle: for easy opening



Pipe cover: excentric and horizontal stepless adjustment; height 50mm, to cover dilatations of the downpipe



HL Rain hopper - HL600NHO

With curtain walls the downpipe very often is hidden between the brick wall and the curtain facade. In this case a normal rain hopper may not be used, as the opening of the lid no longer is possible. Beside of that there has to be a watertight connection between downpipe and rain hopper. We have got the solution: HL600NHO! With all advantages of the new rain hopper HL600N, but with a watertight socket connection DN110!



HL rain hoppers - HL601i The perfect extension for every kind of surface

The accessory HL601i (like individual) creates your individual pavement design around the house

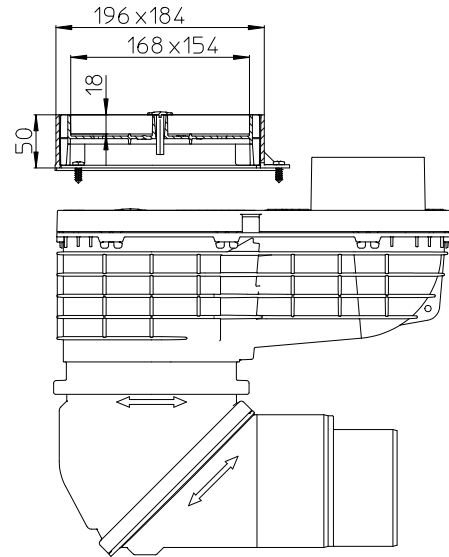

HL rain hoppers – HL600N Installation instructions



1. Place rain hopper



2. Chose and insert the right pipe cover



3. Connect to the down pipe



4. Adjust angle to the sewer



5. Connect to sewer
DN110 - directly
DN125 - Cut with a saw



6. Ready

HL Rain hoppers - HL600N - Maintenance / cleaning



1. Contamination by e.g. leafs



2. Open lid



3. Empty leaf catcher

HL Rain hoppers – Products – Data

HL600N High capacity rain hopper with flexible ball joint

HL600NG Rain hopper like HL600N, but with visible parts made of cast iron

Data	
Capacity	DN100: 10l/s DN125: 11l/s
Material	HL600N: PP HL600NG: PP/Guss
Inlet	Pipe joints DN80, DN100, DN120
Outlet	DN110 or DN125, horizontally and vertically adjustable from 0° to 90°
Trap	Frost proofed flap with rubber gasket
Standard	DIN 12056, Önorm B 2501
Recommended for	Connection downpipe to sewer with inspection possibility
Including	Leaf catcher with overflow, with pipe joints for downpipes Ø 80, 100, 120 and lid with rubber gasket
Add. information	Suitable for outdoor

HL600N

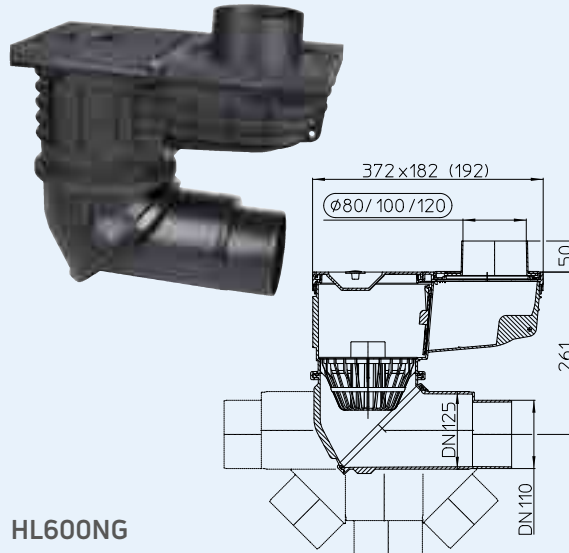

HL600NG

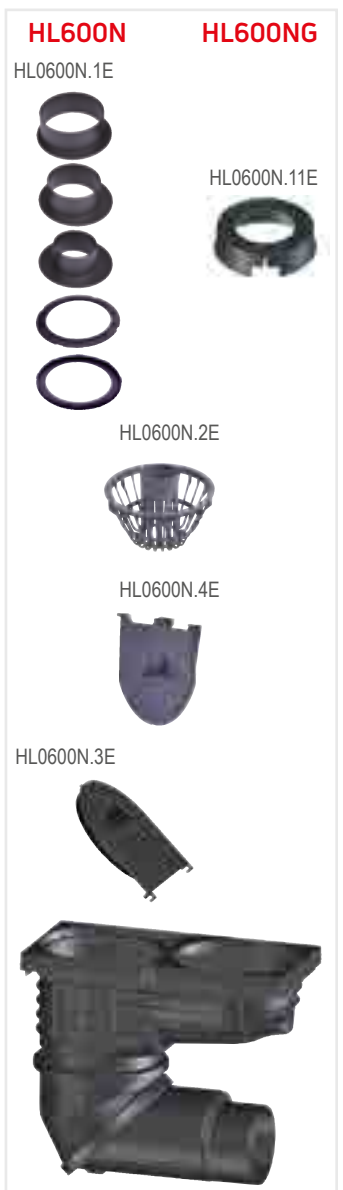
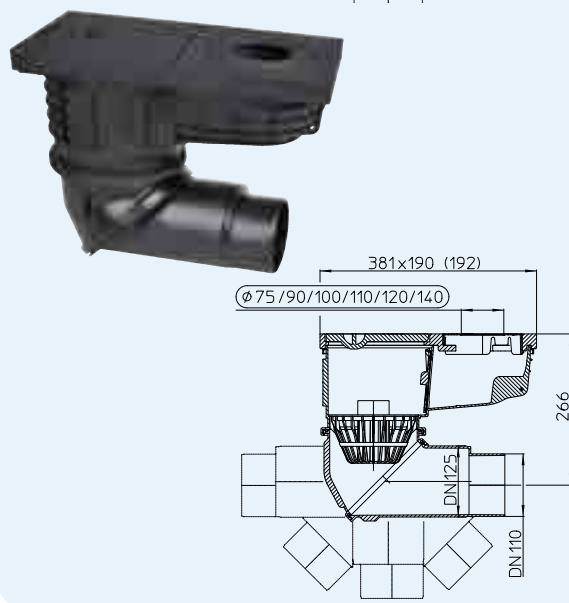

HL-No	Dimension	Surface	Weight	EAN	Piece/package
600N	DN110/125	PP	1627 g	+044122	1
600NG	DN110/125	Guss	8800 g	+044696	1

HL601i Extension for individual pavement styling

Data	
Material	PP
Height	5 cm
Recomm. for	Filling of gravel, tiles stones...to style your individual pavement around the house. Equipped with lid for easy cleaning and maintenance

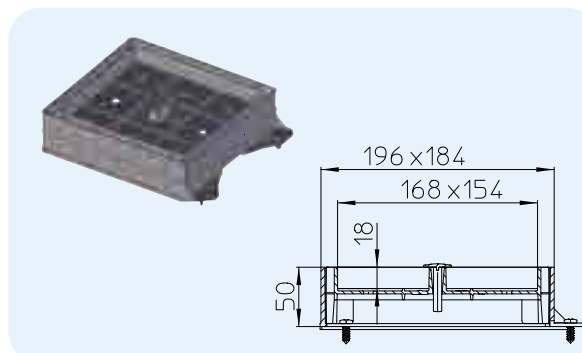

HL-No	Dimension	Weight	EAN	Piece/package
601i	196x184 mm	328 g	+044191	1

HL600NHO Rain hopper with horizontal inlet for curtain walls

HL600NGHO Rain hopper like HL600NHO, but with visible parts made of cast iron

Data

Capacity	DN100: 10l/s DN125: 11l/s
Material	HL600NHO: PP HL600NGHO: PP/Guss
Inlet	DN110 socket
Outlet	DN110 or DN125, horizontally and vertically adjustable from 0° to 90°
Trap	Frost proofed flap with rubber gasket
Standard	DIN 12056, Önorm B 2501
Recommended for	Connection of downpipe to sewer behind a curtain wall
Including	Leaf catcher with overflow
Add. information	Suitable for outdoor

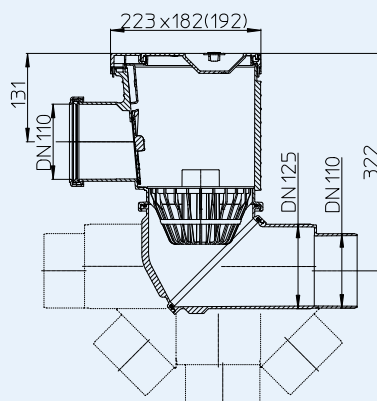
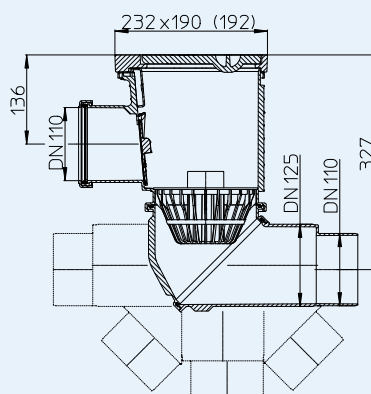
HL600NHO

HL600NGHO

HL600NHO HL600NGHO

HL0600N.2E



HL0600N.4E



HL0600N.3E



HL-No	Dimension	Surface	Weight	EAN	Piece/package
600NHO	DN110/125	PP	1556 g		1
600NGHO	DN110/125	Guss	6400 g		1

HL660/2, HL660/2-80 Rain hopper
HL660E Rain hopper

Data

Capacity	6,6 l/s
Material	PP (Polipropilen)
Connection dimension	DN110/125
Outlet	Vertical
Stench trap	Frostproof flap
Standard	DIN 19560
Recommended for	Connection between rainwater downpipe and sewage pipe
Including	Leaf catcher, cleaning flap, adapter rings for downpipes HL660/2: Ø 75, 90, 100, 110 mm HL660/2-80: Ø 80, 100, 110 mm HL660E adapter insert, Ø 75 - 120 mm (to be cut out)

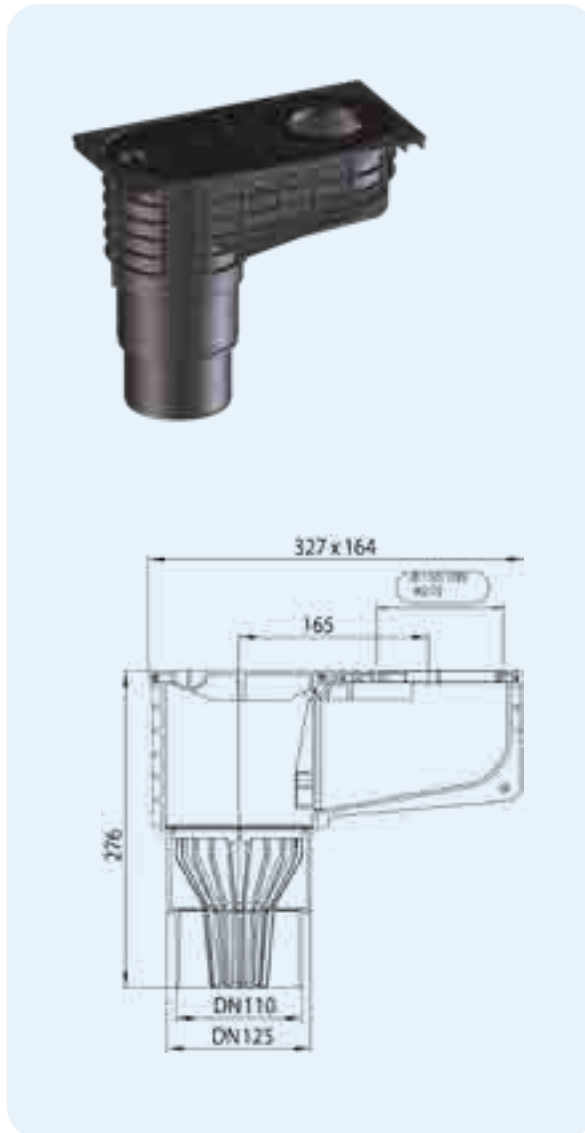

HL660E



HL0600.10E

HL660/2-80



HL660/2



HL0600.1E



HL0600.02E



HL0600.4E



HL0600.3E



HL-No.	Dimension	Weight	EAN	Piece/package
660/2	DN110/125	800 g	+011902	1
660/2-80	DN110/125	800 g	+012626	1
660E	DN110/125	800 g	+029556	1



SIPHONS ABLÄUFE

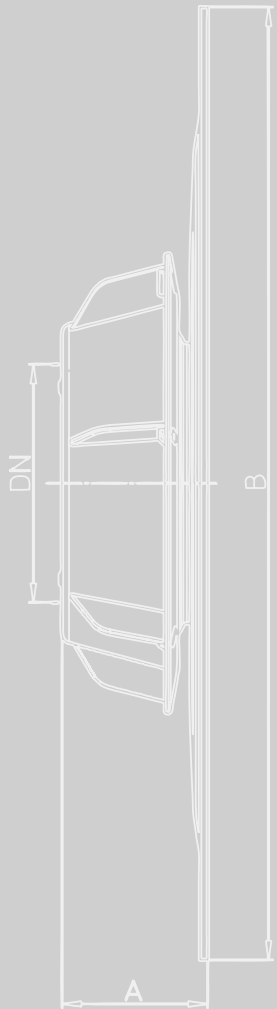
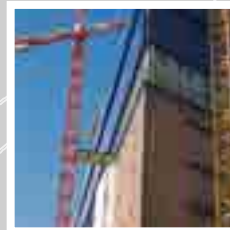
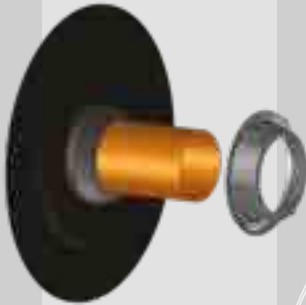

6 METER
OFF-DICHTHEITSGEPRÜFT
WASSERSÄULE



HL Pipe sleeves

18. Waterproofings for buildings

18



HL Waterproofings for buildings

Basic information about design and installation

In most cases these parts of buildings, which are in contact with earth moisture or with non-pressure water are sealed with bitumen waterproofings or liquid bitumen compounds. For pressure water only 2-layer bitumen waterproofings are allowed. It is obvious, that it comes to leakage very seldom in the surface, but very often at sensitive spots like wall break-throughs. Standard pipe inflow channels are installed in the shuttering and are poured out with concrete. This guarantees a tight connection between pipe and concrete. Afterwards the basement wall is sealed with bitumen. In the past the connection between bitumen and pipe inflow channel was the problem. But especially here one has to care for a perfect sealing, to protect from water or moisture getting behind the waterproofing. HL has solved this problem with its series HL800 and 801 pipe sleeves.

Advantages of these series:

- ▲ HL800/801 may be installed also after the finishing of the wall by a taphole or by chiseling out.
- ▲ The connection to the waterproofing is harmless, namely without burning the pipe, because of the pre-fixed bitumen sleeve.
- ▲ Also liquid bitumen compounds may be welded to the bitumen sleeve.
- ▲ Possible deviations of the pipe because of the weight of soil are compensated by the use of a special gasket ($\pm 10\%$).
- ▲ The sealing between pipe and pipe sleeve works by multiple lip gaskets, combined with a conical thread and a squeeze connection.
- ▲ Due to the flexible construction the usage near edges and corners of walls is possible.
- ▲ In combination of HL800 and HL801 up to 4 pipes of different smaller diameters may be lead through the wall.

Following we would like to give you information to avoid mistakes:

- ▲ Please take care, that the installation is made latest during the laying of the pipes, as an installation afterwards is not possible.
- ▲ We recommend to imbed the sleeve on both sides.
- ▲ Please avoid an overlap of the sleeves. Minimum distance from pipe middle to next pipe middle: 50cm!
- ▲ Waterproofed up to 6m (certified by OFI).
- ▲ Concerning the installation of the pipes please notice all relevant standards.

Relevant standards/directives

ÖNorm B7209 Waterproofing of buildings, following ÖNorm B3692

ÖNorm B2209-1 Waterproofing of buildings

Directive for the calculation, installation and control of waterproofings for buildings; available at: IFB-Institut für Flachdachbau und Bauwerksabdichtung (www.ifb.co.at)

A long lasting waterproofing for buildings may only be guaranteed, if a specific planing of the sealing and all detailed solutions and their combinations are secured. Especially for highly recurrent problems a lot of standardized solutions have been developed and may be downloaded unter www.ifb.co.at



HL Waterproofings for buildings - Product Overview

Product



Product	HL800 (/110), (/125), (/160)	HL800/63-75	HL800/40-50	HL800.2/40-50 HL800.2/63-75
Description	Bitumene pipe sleeve DN110, DN125 or DN160	Bitumene pipe sleeve 63-75 mm	Bitumene pipe sleeve 40-50 mm	Double bitumene pipe sleeve 40-50 mm or 63-75 mm
Function	For a tight connection between pipe and bitumen waterproofing	For a tight connection between pipe or cable and bitumen waterproofing	For a tight connection between pipe or cable and bitumen waterproofing	For two smooth medium size pipes or cables with outer diameter 40-50 mm or 63-75 mm, e.g. heating pumps

Product



Product	HL800/160	HL801	HL801V...	HL804H(/50)(/110)
Description	Bitumene pipe sleeve DN160	Multiple pipe fairlead	Screw	Sealing kit with bitumen collar DN50 or DN110
Function		To lead 4 pipes with diameter 8 - 52 mm through the wall. Usage only in combination with HL800/160 and HL801V!	To lead one pipe with diameter 8 - 52 mm through the wall. Usage only in combination with HL800/160 and HL801!	For sealing plain, vertical pipe feedthroughs with outer diameters of 50 and 110 mm

Accessories



Product	HL801R	HL801B
Description	Reduction screw	Plug
Function	To reduce the opening for smaller pipes or cables	To close erroneously opened wholes in HL801

HL HL800 Pipe sleeve – Installation



1. Pipe with socket, wall with liquid bitumen compound



2. Set on bitumen sleeve



3. ... And push close to the wall



4. Screw on the nut



5. Weld the bitumen waterproofing



6. Fix the nut

HL HL801 Multiple pipe fairlead – Installation



1. Fix HL800/160 on the building and connect to the waterproofing



2. Select the fitting screws, depending on the quantity and the diameter of pipes/cables and open the predetermined breaking points.



3. Connect the screws with the pipe fairlead and fix the screws



4. Insert the ready prepared pipe fairlead HL801 into the pipe sleeve HL800/160 and fix the nut of HL800



5. Pull the pipes/cables through and fix them with the nuts



6. Ready!

HL Waterproofing for buildings - Products details

HL800 Pipe sleeve with pre-welded bitumen flange for pipes

Data

Material	Rubber/bitumen/PP
Connection dimension	HL800/110: Ø 110 - 115 mm HL800/125: Ø 125 - 130 mm HL800/160: Ø 160 - 165 mm HL800/63-75: Ø 63 - 75 mm HL800/40-50: Ø 40 - 50 mm HL800/32: Ø 30 - 34 mm
Waterproof up to	6 m of water column
Recommended for	Bitumene waterproofings or liquid bitumene compounds
Additional information	The smooth connection between pipe and waterproofing is 100% tight

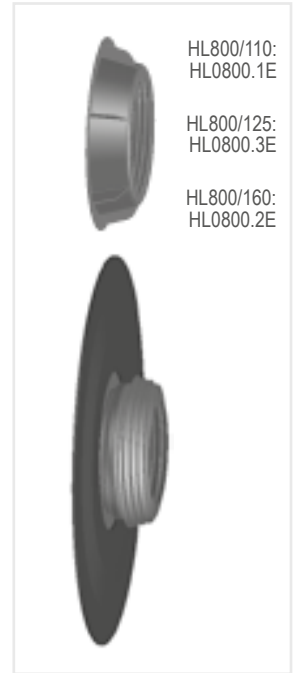
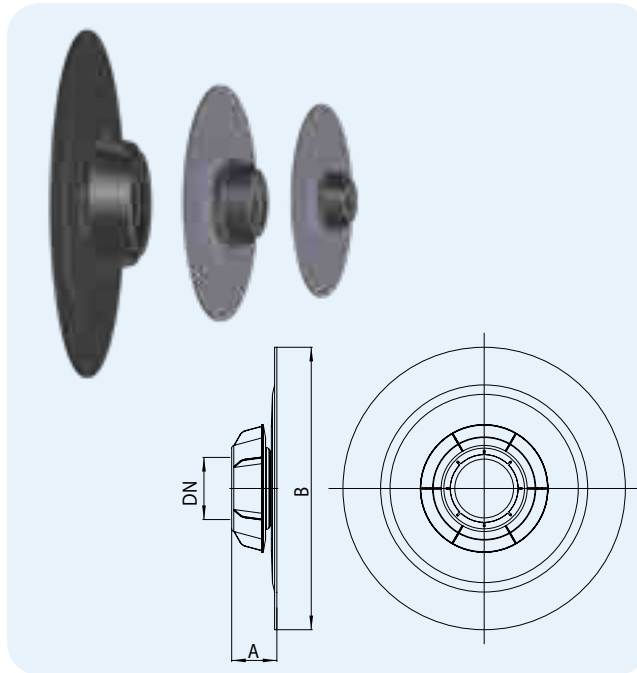

For additional information for combining different pipe dimensions, please use our website www.hl.at under section installation ABC

	DN	A	B	HL-No.	Dimension	Material	Weight	EAN	Piece/package
HL800/32	32	55 mm	400 mm	800/32	DN32	Bitumen	810 g	+003686	1
HL800/40-50	40/50	57 mm	400 mm	800/40-50	DN40/50	Bitumen	810 g	+038305	1
HL800/63-75	63/75	57 mm	380 mm	800/63-75	DN63/75	Bitumen	920 g	+038275	1
HL800/110	110	80 mm	500 mm	800/110	DN110	Bitumen	1800 g	+021598	1
HL800/125	125	80 mm	500 mm	800/125	DN125	Bitumen	1900 g	+028276	1
HL800/160	160	80 mm	560 mm	800/160	DN160	Bitumen	2200 g	+021611	1

HL800.2/40-50 Double pipe sleeve with pre-welded bitumene flange

Data

Material	Rubber/Bitumene
Connection	Ø 40 -50 mm
Waterproof up to	6 m water column
Recommended for	Liquid bitumene compounds, bitumene waterproofings
Additional information	The smooth connection between pipe and waterproofing is 100% tight; for e.g. heating pumps

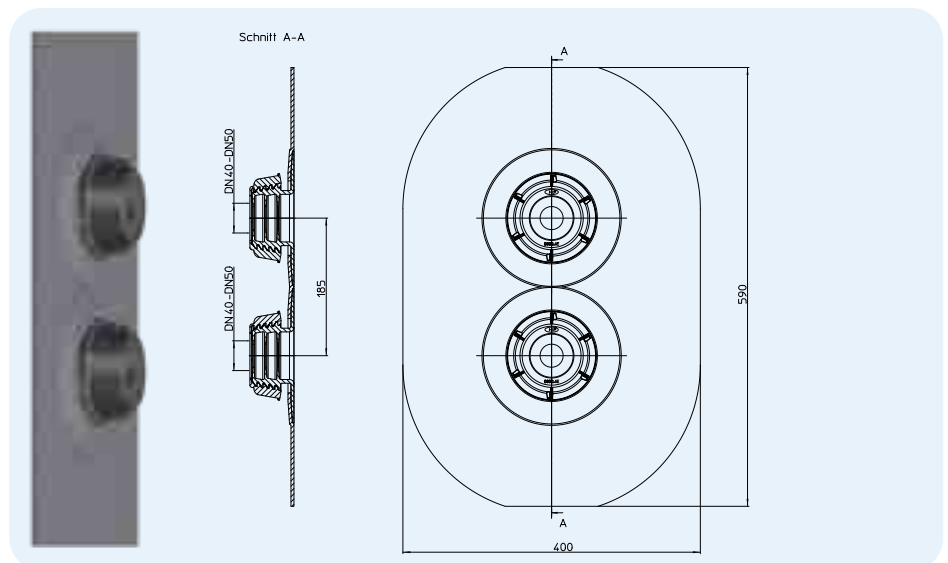

For additional information for combining different pipe dimensions, please use our website www.hl.at under section installation ABC

HL-No.	Dimension	Weight	EAN	Piece/package
800.2/40-50	DN40/50	1538 g	+03828	1

HL800.2/63-75 Double pipe sleeve with pre-welded bitumene flange

Data

Material	Rubber/Bitumene
Connection	Ø 63 - 75 mm
Waterproof up to	6 m water column
Recommended for	Liquid bitumene compounds, bitumene waterproofings
Additional information	The smooth connection between pipe and waterproofing is 100% tight; for e.g. heating pumps

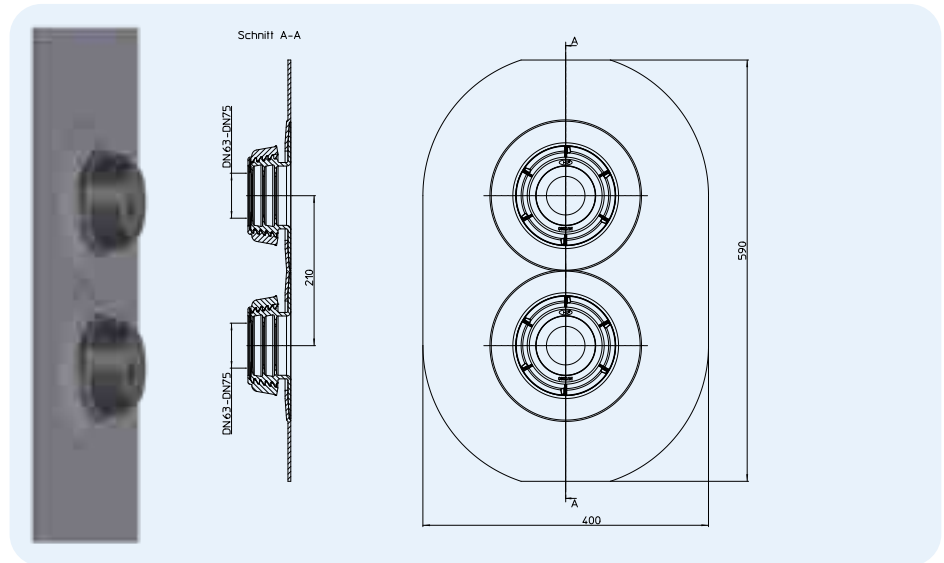

For additional information for combining different pipe dimensions, please use our website www.hl.at under section installation ABC

HL-No.	Dimension	Weight	EAN	Piece/package
800.2/63-75	DN63-75	1693 g	+03829	1

HL801 Multiple pipe fairlead for pipes or cables 8 - 52 mm

Data

Material	PP
Predetermined breaking points	Ø 32/40/50/63 mm
Waterproof up to	6 m water column
Recommended for	Attention: Usage only in combination with HL 800/160 pipe sleeve
Additional information	Up to 4 pipes or cables may be lead through the wall, see „quick search“.

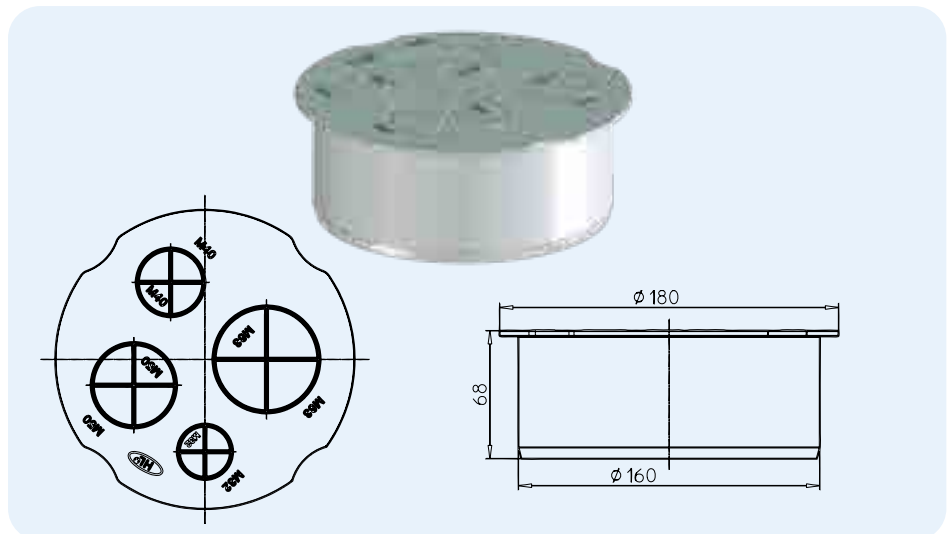

For additional information for combining different pipe dimensions, please use our website www.hl.at under section installation ABC

HL-No.	Dimension	Weight	EAN	Piece/package
801	Ø M32/40/50/63	180 g	+028771	1

HL804H Sealing kit with bitumen collar

Data

Material	TPE, PP, bitumen
Connection	HL804H/50: Ø 50 mm HL804H/110: Ø 110 mm
Recommended for	foundation plates, intermediate ceilings, and as pipe sealing for sealing classes W4 and W5.
Additional information	Protection against rising capillary moisture through connection between pipe feed-through and structural waterproofing.

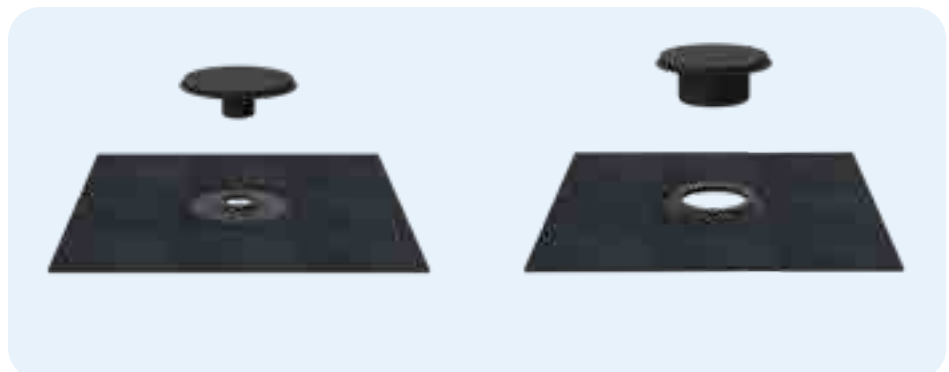

HL-No.	Dimension	Weight	EAN	Piece/package
804H/50	DN50	1700 g	+003723	1
804H/110	DN110	1700 g	+003709	1

HL801V Screw, fits to HL801

Data

Material	PA
Connection	HL801V/8-14
dimension	HL801V/10-17
	HL801V/17-25
	HL801V/22-33
	HL801V/28-38
	HL801V/32-44
	HL801V/40-52
Waterproof up to	6 m water column



HL-No.	Dimension Ø	Weight	EAN	Piece/package
801V/8-14	8 – 14 mm	30 g	+028795	1
801V/10-17	10 – 17 mm	30 g	+039240	1
801V/17-25	17 – 25 mm	50 g	+028818	1
801V/22-33	22 – 33 mm	90 g	+028825	1
801V/28-38	28 – 38 mm	130 g	+028832	1
801V/32-44	32 – 44 mm	180 g	+028849	1
801V/40-52	40 – 52 mm	230 g	+028856	1

For additional information for combining different pipe dimensions, please use our website www.hl.at under section installation ABC

HL801R Screw reduction, fits to HL801

Data

Material	PA
Connection	Reductions from M63 – 25
dimension	
Waterproof up to	6 m water column



HL-No.	Reduction from/to	Weight	EAN	Piece/package
801R/M32-25	M32 – 25	15 g	+028863	1
801R/M40-25	M40 – 25	20 g	+028870	1
801R/M40-32	M40 – 32	20 g	+028887	1
801R/M50-25	M50 – 25	50 g	+028894	1
801R/M50-32	M50 – 32	50 g	+028900	1
801R/M50-40	M50 – 40	50 g	+028917	1
801R/M63-32	M63 – 32	90 g	+028924	1
801R/M63-40	M63 – 40	90 g	+028931	1
801R/M63-50	M63 – 50	90 g	+028948	1

For additional information for combining different pipe dimensions, please use our website www.hl.at under section installation ABC

HL801B Plug, fits to HL801

Data









Material	PA
Connection	M32, M40, M50, M63
dimension	
Waterproof up to	6 m water column
Additional information	To close erroneously opened wholes in HL801



HL-No.	Reduction from/to	Weight	EAN	Piece/package
801B/M32	M32	15 g	+028955	1
801B/M40	M40	20 g	+028962	1
801B/M50	M50	50 g	+028979	1
801B/M63	M63	80 g	+028986	1

For additional information for combining different pipe dimensions, please use our website www.hl.at under section installation ABC

Quick search for HL801V/R/B

	M32		M40		M50		M63		
Ø									
8	HL801V/8-14 +	HL801R/M32-25	HL801V/8-14 +	HL801R/M40-25	HL801V/8-14 +	HL801R/M50-25	HL801V/8-14 +	HL801R/M63-32 +	HL801R/M32-25
9	HL801V/8-14 +	HL801R/M32-25	HL801V/8-14 +	HL801R/M40-25	HL801V/8-14 +	HL801R/M50-25	HL801V/8-14 +	HL801R/M63-32 +	HL801R/M32-25
10	HL801V/8-14 +	HL801R/M32-25	HL801V/8-14 +	HL801R/M40-25	HL801V/8-14 +	HL801R/M50-25	HL801V/8-14 +	HL801R/M63-32 +	HL801R/M32-25
11	HL801V/8-14 +	HL801R/M32-25	HL801V/8-14 +	HL801R/M40-25	HL801V/8-14 +	HL801R/M50-25	HL801V/8-14 +	HL801R/M63-32 +	HL801R/M32-25
12	HL801V/8-14 +	HL801R/M32-25	HL801V/8-14 +	HL801R/M40-25	HL801V/8-14 +	HL801R/M50-25	HL801V/8-14 +	HL801R/M63-32 +	HL801R/M32-25
13	HL801V/8-14 +	HL801R/M32-25	HL801V/8-14 +	HL801R/M40-25	HL801V/8-14 +	HL801R/M50-25	HL801V/8-14 +	HL801R/M63-32 +	HL801R/M32-25
14	HL801V/8-14 +	HL801R/M32-25	HL801V/8-14 +	HL801R/M40-25	HL801V/8-14 +	HL801R/M50-25	HL801V/8-14 +	HL801R/M63-32 +	HL801R/M32-25
15	HL801V/10-17 +	HL801R/M32-M25	HL801V/10-17 +	HL801R/M40-M25	HL801V/10-17 +	HL801R/M50-M25	HL801V/10-17 +	HL801R/M63-M32 +	HL801R/M32-M25
16	HL801V/10-17 +	HL801R/M32-M25	HL801V/10-17 +	HL801R/M40-M25	HL801V/10-17 +	HL801R/M50-M25	HL801V/10-17 +	HL801R/M63-M32 +	HL801R/M32-M25
17	HL801V/17-25	-	HL801V/17-25 +	HL801R/M40-32	HL801V/17-25 +	HL801R/M50-32	HL801V/17-25 +	HL801R/M63-32	-
18	HL801V/17-25	-	HL801V/17-25 +	HL801R/M40-32	HL801V/17-25 +	HL801R/M50-32	HL801V/17-25 +	HL801R/M63-32	-
19	HL801V/17-25	-	HL801V/17-25 +	HL801R/M40-32	HL801V/17-25 +	HL801R/M50-32	HL801V/17-25 +	HL801R/M63-32	-
20	HL801V/17-25	-	HL801V/17-25 +	HL801R/M40-32	HL801V/17-25 +	HL801R/M50-32	HL801V/17-25 +	HL801R/M63-32	-
21	HL801V/17-25	-	HL801V/17-25 +	HL801R/M40-32	HL801V/17-25 +	HL801R/M50-32	HL801V/17-25 +	HL801R/M63-32	-
22	HL801V/17-25	-	HL801V/22-33	-	HL801V/17-25 +	HL801R/M50-32	HL801V/17-25 +	HL801R/M63-32	-
23	HL801V/17-25	-	HL801V/22-33	-	HL801V/17-25 +	HL801R/M50-32	HL801V/17-25 +	HL801R/M63-32	-
24	HL801V/17-25	-	HL801V/22-33	-	HL801V/17-25 +	HL801R/M50-32	HL801V/17-25 +	HL801R/M63-32	-
25	HL801V/17-25	-	HL801V/22-33	-	HL801V/17-25 +	HL801R/M50-32	HL801V/17-25 +	HL801R/M63-32	-
26	-	-	HL801V/22-33	-	HL801V/22-33 +	HL801R/M50-40	HL801V/22-33 +	HL801R/M63-40	-
27	-	-	HL801V/22-33	-	HL801V/22-33 +	HL801R/M50-40	HL801V/22-33 +	HL801R/M63-40	-
28	-	-	HL801V/22-33	-	HL801V/28-38	-	HL801V/22-33 +	HL801R/M63-40	-
29	-	-	HL801V/22-33	-	HL801V/28-38	-	HL801V/22-33 +	HL801R/M63-40	-
30	-	-	HL801V/22-33	-	HL801V/28-38	-	HL801V/22-33 +	HL801R/M63-40	-
31	-	-	HL801V/22-33	-	HL801V/28-38	-	HL801V/22-33 +	HL801R/M63-40	-
32	-	-	HL801V/22-33	-	HL801V/28-38	-	HL801V/22-33 +	HL801R/M63-40	-
33	-	-	HL801V/22-33	-	HL801V/28-38	-	HL801V/22-33 +	HL801R/M63-40	-
34	-	-	-	-	HL801V/28-38	-	HL801V/32-44	-	-
35	-	-	-	-	HL801V/28-38	-	HL801V/32-44	-	-
36	-	-	-	-	HL801V/28-38	-	HL801V/32-44	-	-
37	-	-	-	-	HL801V/28-38	-	HL801V/32-44	-	-
38	-	-	-	-	HL801V/28-38	-	HL801V/32-44	-	-
39	-	-	-	-	HL801V/28-38	-	HL801V/32-44	-	-
40	-	-	-	-	HL801V/32-44	-	HL801V/32-44	-	-
41	-	-	-	-	HL801V/32-44	-	HL801V/32-44	-	-
42	-	-	-	-	HL801V/32-44	-	HL801V/32-44	-	-
43	-	-	-	-	HL801V/32-44	-	HL801V/32-44	-	-
44	-	-	-	-	HL801V/32-44	-	HL801V/32-44	-	-
45	-	-	-	-	HL801V/40-52	-	HL801V/40-52	-	-
46	-	-	-	-	HL801V/40-52	-	HL801V/40-52	-	-
47	-	-	-	-	HL801V/40-52	-	HL801V/40-52	-	-
48	-	-	-	-	HL801V/40-52	-	HL801V/40-52	-	-
49	-	-	-	-	HL801V/40-52	-	HL801V/40-52	-	-
50	-	-	-	-	HL801V/40-52	-	HL801V/40-52	-	-
51	-	-	-	-	HL801V/40-52	-	HL801V/40-52	-	-
52	-	-	-	-	HL801V/40-52	-	HL801V/40-52	-	-

For additional information for combining different pipe dimensions, please use our website www.hl.at under section installation ABC



SIPHONS ABLÄUFE



HL Products

19. Accessories

19

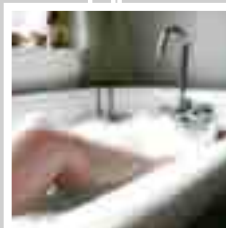

HL Fire protection – Function

Function in case of fire

This assembly prevents the spread of fire to another floor. Intumescent material in the metal housing starts to expand at a temperature of 150°C and completely seals the hole in the ceiling. Heat, fire and smoke cannot pass into the next fire section.

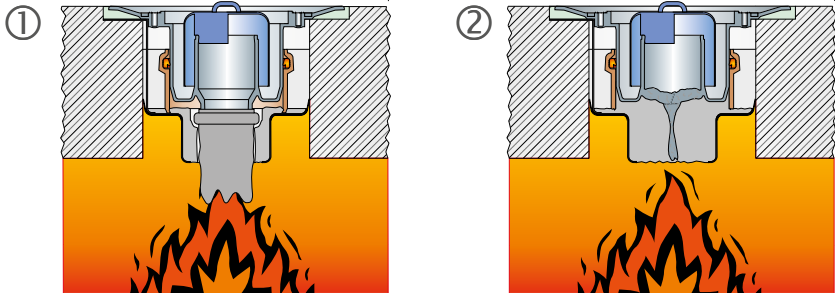

HL Fire protection – Sectional drawings

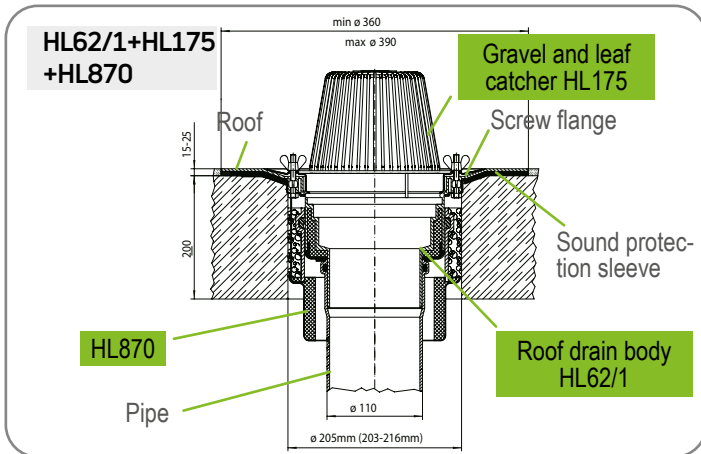
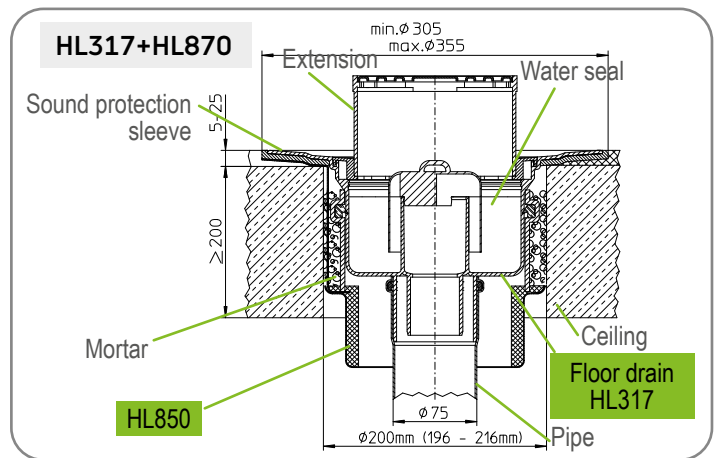
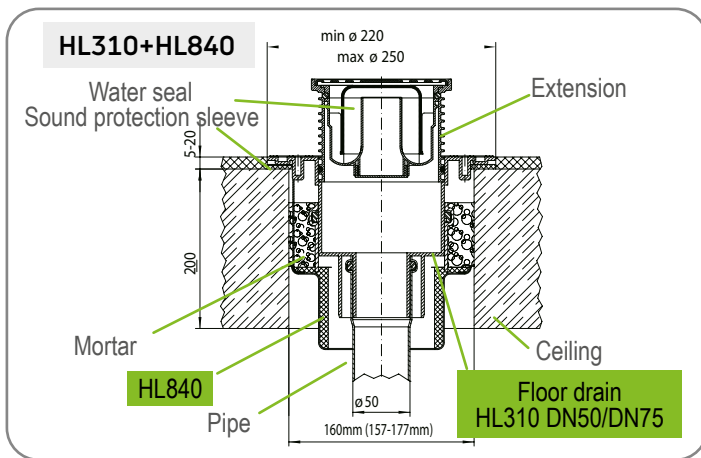

HL Fire protection – Installation steps

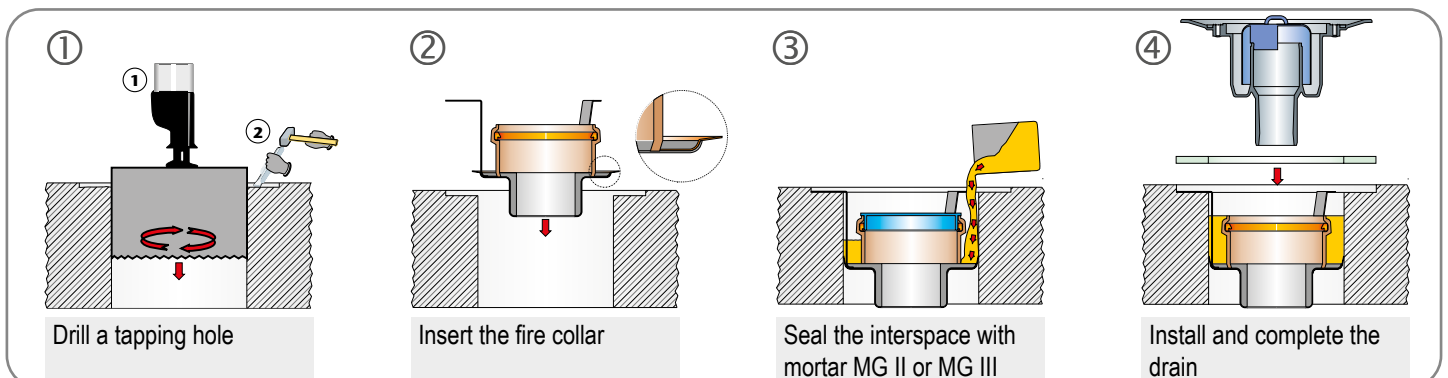

HL Accessories – Products – Data

HL840 Fire protection collar

Data

Fire protection class	R90/120
Tapping hole diameter	HL840: Ø 160 mm (157 – 177 mm)
Fits to	HL310-series DN50/75

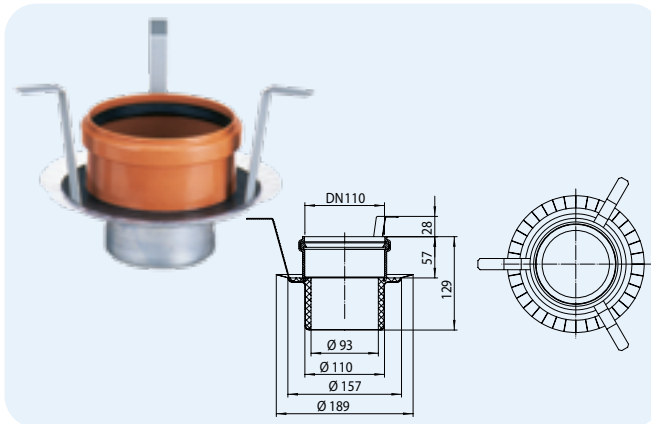

HL-No. 840	Dimension Ø 110 / 93 mm	Weight 830 g	EAN +015184	Piece/package 1
---------------	----------------------------	-----------------	----------------	--------------------

HL870 Fire protection collar

Data

Fire protection class	R90/120
Tapping hole diameter	HL870: Ø 200 mm (196 – 216 mm)
Fits to	HL317 DN110, HL62 DN110

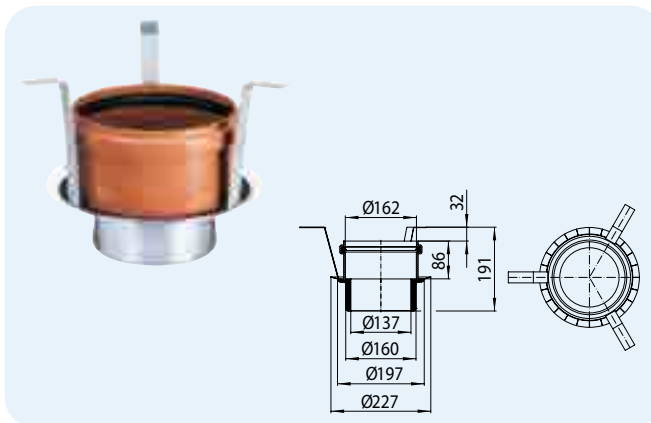

HL-No. 870	Dimension Ø 162 / 137 mm	Weight 1700 g	EAN +030729	Piece/package 1
---------------	-----------------------------	------------------	----------------	--------------------

HL9 Socket connector

Data

Material	PP
Function	Connection between plastic and cast iron or lead pipes in flow direction

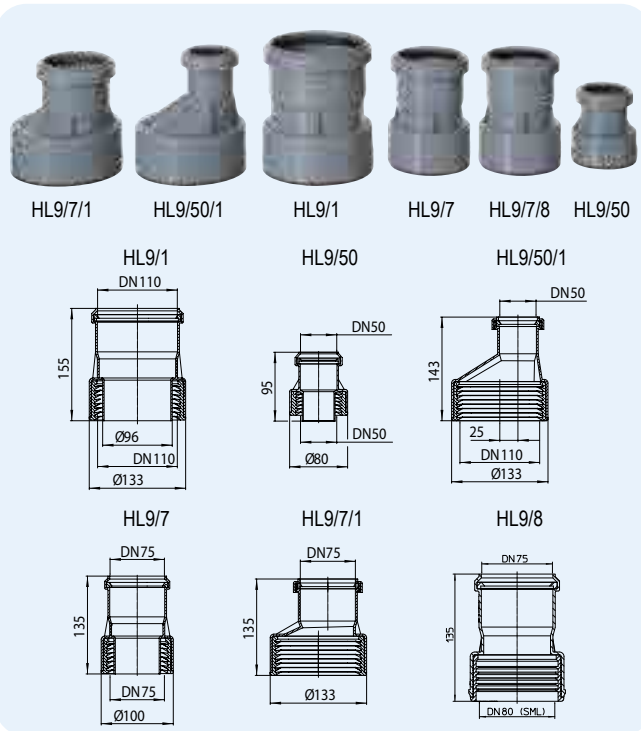

HL9/1: HL01064D
 HL9/50: HL01062D
 HL9/50/1: HL01062D
 HL9/7: HL01063D
 HL9/7/8: HL010163D
 HL9/7/1: HL01063D



HL9/1: HL01029D
 HL9/50/1: HL01029D
 HL9/50: HL01027D
 HL9/7: HL01028D
 HL9/7/8: HL01112D
 HL9/7/1: HL01029D



HL-No.	Dimension	Weight	EAN	Piece/package
9/50	DN50	130 g	+900954	1
9/7	DN75	230 g	+900978	1
9/1	DN110	380 g	+909100	1
9/50/1	DN50/110	145 g	+929511	1
9/7/1	DN75/110	150 g	+926719	1

HL9ET Socket connector

Data

Material	PP
Function	Connection between plastic and eternit pipes in flow direction

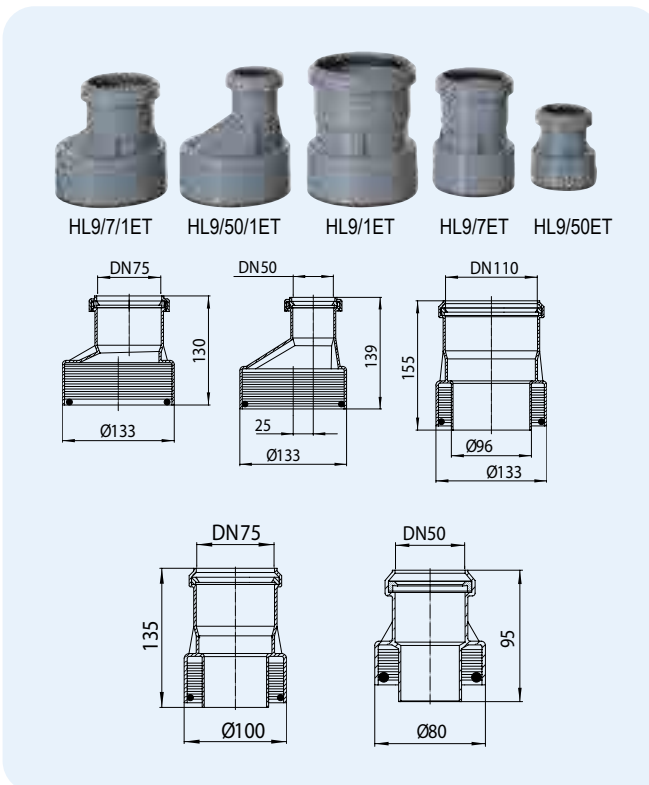

HL9/1ET: HL01064D
 HL9/50ET: HL01062D
 HL9/50/1ET: HL01062D
 HL9/7ET: HL01063D
 HL9/7/1ET: HL01063D



HL9/1ET: HL01083D
 HL9/50ET: HL01085D
 HL9/50/1ET: HL01083D
 HL9/7ET: 01084D
 HL9/7/1ET: HL01083D

HL-No.	Dimension	Weight	EAN	Piece/package
9/50ET	DN50	130 g	+910953	1
9/7ET	DN75	230 g	+910977	1
9/1ET	DN110	380 g	+919109	1
9/50/1ET	DN50/110	145 g	+939954	1
9/7/1ET	DN75/110	150 g	+939978	1

HL98, HL98SML Rodding eye

Data

Material	PP / Stainless steel
Load classification	L15 - max. 1,5 t
Function	For installation in the floor or in the wall, connection to plastic pipe sockets or SML-pipes.

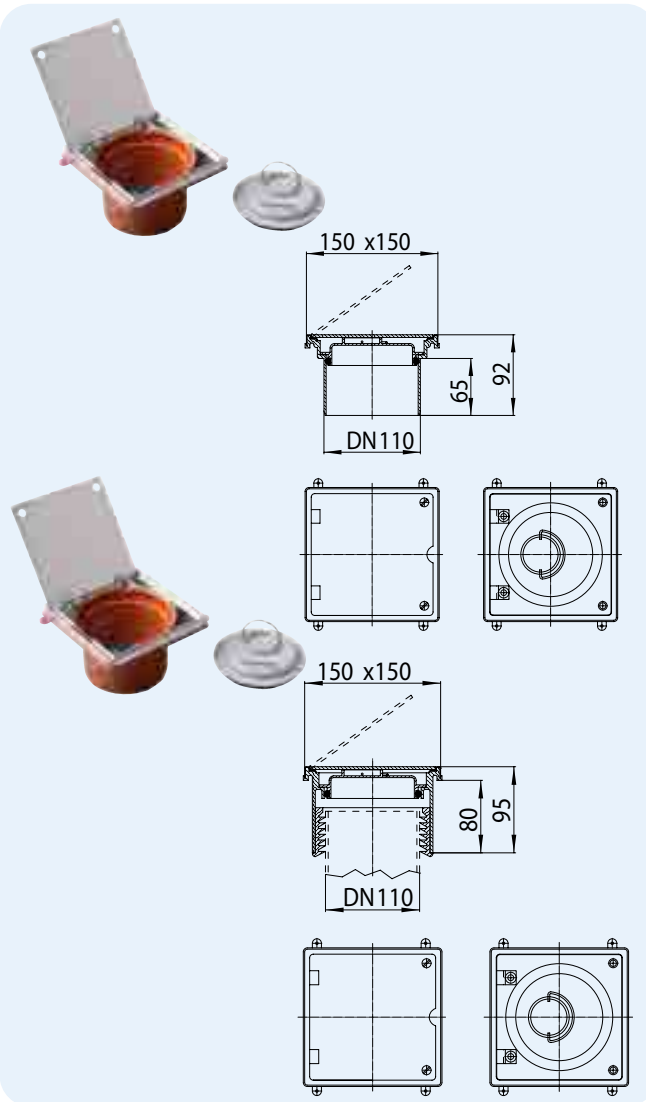
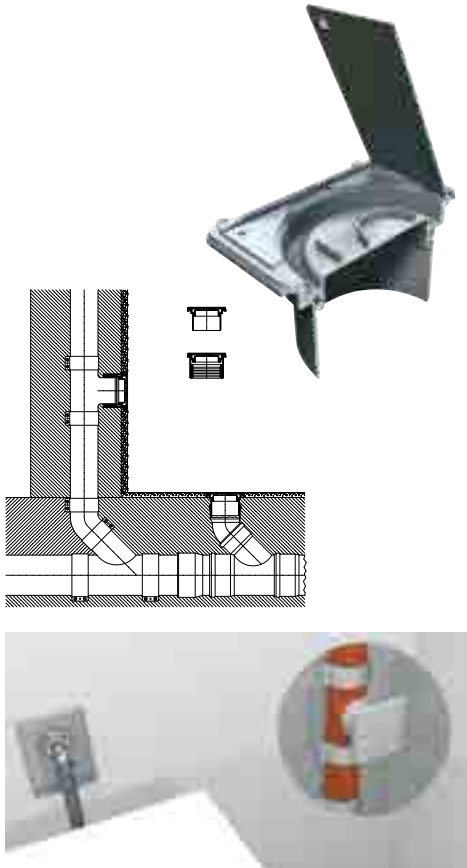

HL-No.	Dimension	Weight	EAN	Piece/package
98	DN110	840 g	+701988	1
98SML	DN110	1040 g	+012688	1

HL5 Brass-soldering connector with O-ring

Data

Material	Brass
Function	Connection between plastic and lead in flow direction

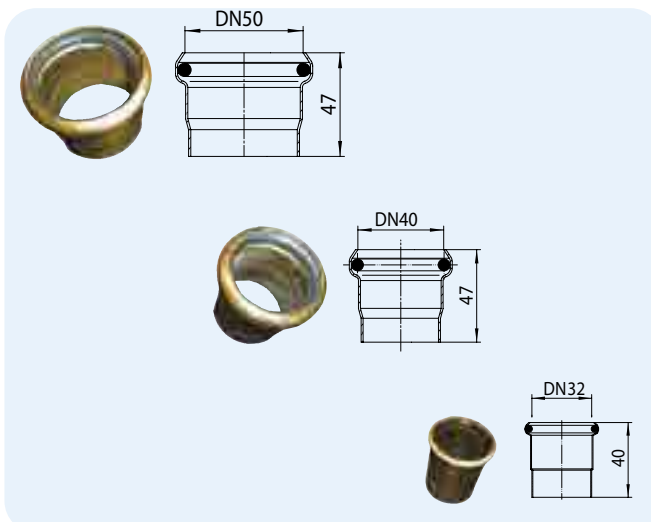

HL-No.	Dimension	Weight	EAN	Piece/package
5/30	DN32	20 g	+100538	10
5/40	DN40	60 g	+100057	10
5/50	DN50	80 g	+100552	10

HL30, HL40, HL41 Universal connector
Data

Material PE, pluggable and weldable
 Function Connector for not-pressure pipe works; with stainless steel banding

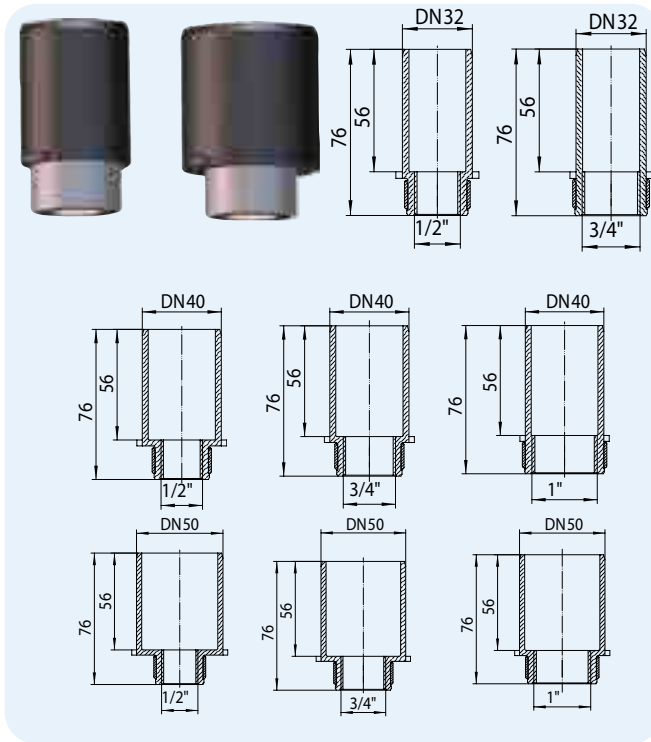

HL-No.	Dimension	Weight	EAN	Piece/package
30.2	DN32 x R1/2"	30 g	+004461	10
30.3	DN32 x R3/4"	38 g	+004485	10
40.2	DN40 x R1/2"	36 g	+000692	10
40.3	DN40 x R3/4"	44 g	+000470	10
40.4	DN40 x R1"	54 g	+000487	10
41.2	DN50 x R1/2"	42 g	+000517	10
41.3	DN50 x R3/4"	50 g	+000746	10
41.4	DN50 x R1"	60 g	+000432	10

HL42, HL43 Test plug with vent hole
Data

Material PP
 Function Usage only for pressure test!
 Acc. DIN1988/2 not allowed for permanent pressure!
 Additional information Pressure-resistant up to 15 bar, with flat gasket, massive hexagon socket SW12, blue or red

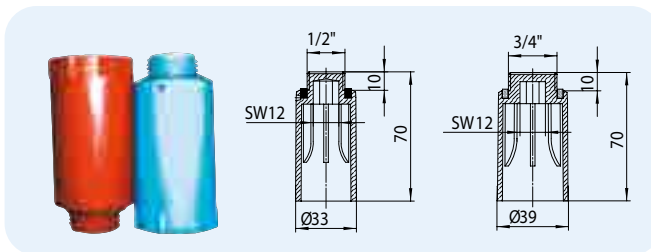

HL-No.	Colour	Dimension	Weight	EAN	Piece/package
42.B	blue	1/2" x Ø 33 mm	23 g	+901425	10
42.R	red	1/2" x Ø 33 mm	23 g	+902422	10
43.B	blue	3/4" x Ø 39 mm	28 g	+901432	10
43.R	red	3/4" x Ø 39 mm	28 g	+902439	10

HL42.MS Test plug with brass thread
Data

Material Brass/PP
 Function Usage for pressure test. Acc. DIN1988/2 a test plug is defined as „permanent tight“ (also after construction time), when it has a metal thread.
 Additional information Pressure-resistant up to 15 bar, with flat gasket, massive hexagon socket SW12, blue or red

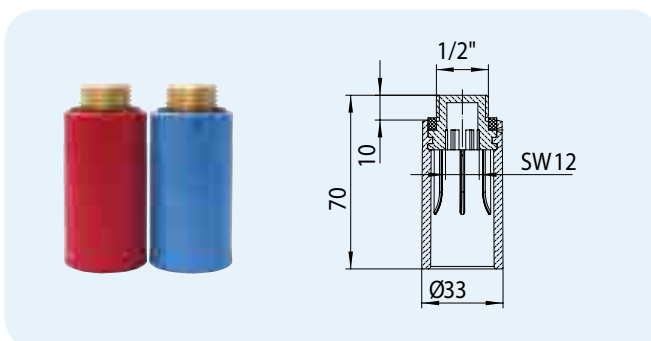

HL-No.	Colour	Dimension	Weight	EAN	Piece/package
42B.MS	blue	1/2" x Ø 33 mm	75 g	+017140	10
42R.MS	red	1/2" x Ø 33 mm	75 g	+017188	10

HL45 Protection plug for drain pipes

Data

Material	PP
Function	To close drainage pipes during construction

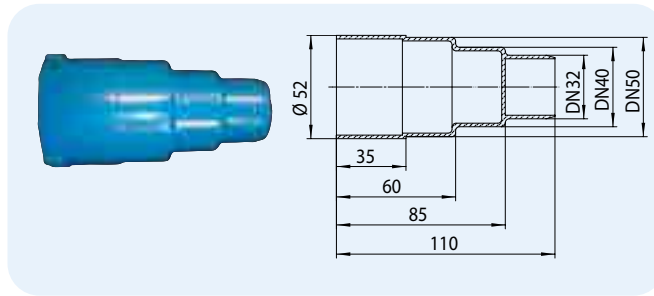

HL-No.	Dimension	Weight	EAN	Piece/package
45	DN32/40/50	27 g	+903450	10

HL805, HL807, HL810 Roof ventpipe fitting

Data

Material	PP
Function	For usage on the roof at the end of downpipes; UV-stabilised

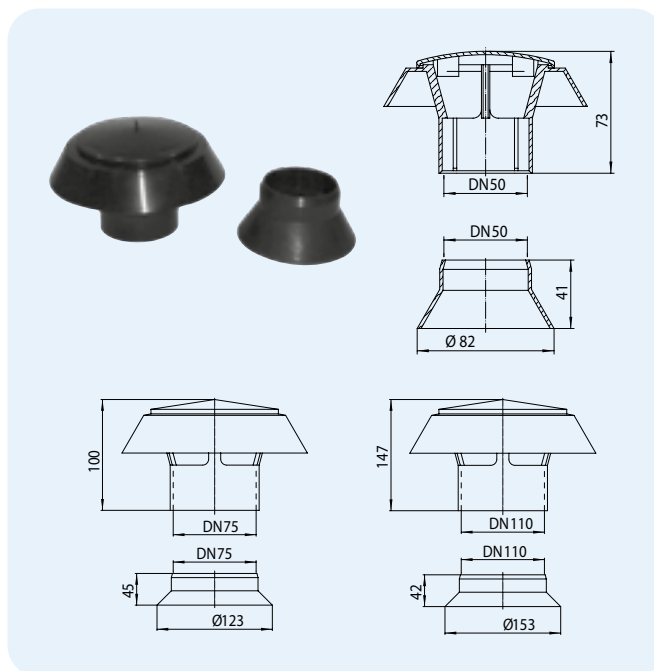
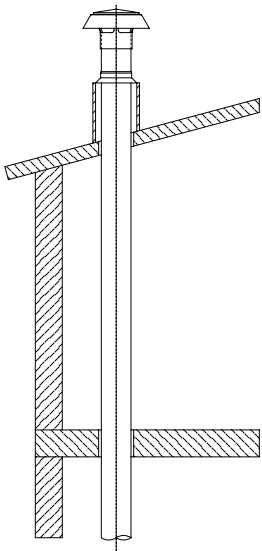

HL-No.	Dimension	Weight	EAN	Piece/package
805	DN50	65 g	+908059	1
807	DN75	140 g	+908073	1
810	DN110	265 g	+908103	1

HL6100 Sound insulation pad

Data

Material	Rubber pad, based on recycled rubber and PU-elastomer
Dimension	500 x 250 x 8 mm
Fits to	shower channels of series HL50



HL-Nr.	Dimension	Weight	EAN	Piece/package
6100	500 x 250 x 8 mm	820 g	+033799	1

HL6200 Sound insulation pad

Data

Material	Rubber pad, based on recycled rubber and PU-elastomer
Dimension	500 x 500 x 8 mm
Fits to	shower channels of HL90, HL300 drains, HL510-series, HL5100



HL-Nr.	Dimension	Weight	EAN	Piece/package
6200	500 x 500 x 8 mm	1640 g	+033805	1

HL6300 Sound insulation pad

Data

Material	Rubber pad, based on recycled rubber and PU-elastomer
Dimension	900 x 450 x 8/4 mm (2 pieces)
Fits to	shower pannel HL523N-90x90



HL-Nr.	Dimension	Weight	EAN	Piece/package
6300	2 Stk. 900 x 450 x 8/4 mm	4540 g	+033812	1

HL6600 Sound insulation pad for HL53.0, HL53Prblue.0

HL6700 Sound insulation pad for HL53FPblue.0

Data

Material	EPS/cork
Dimensions	see techn. drawing
Fits for	drain body HL53.0, HL53Prblue.0 and HL53FPblue.0

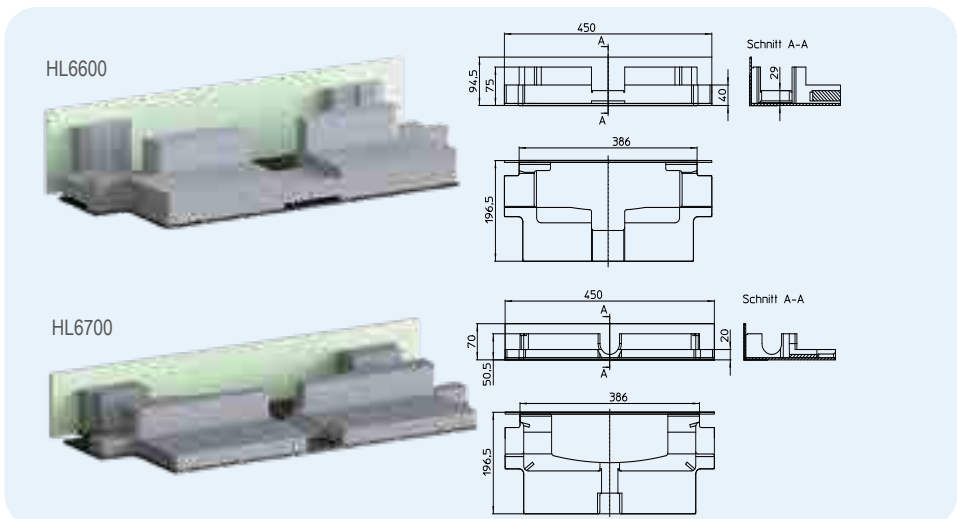

HL-Nr.	Dimension	Weight	EAN	Piece/package
6600	450 x 386 x 196,5 mm	1336 g	+041244	1
6700	450 x 386 x 196,5 mm	1250 g	+041251	1

HL6600.2 Sound insulation pad for HL53Duo.0

Data

Material	EPS/cork
Dimensions	see www.hl.at
Fits for	drain body HL53Duo.0

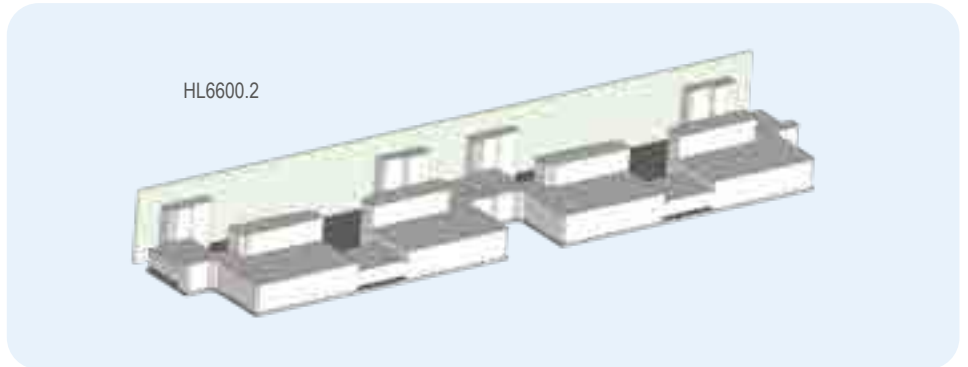

HL-Nr.	Dimension	Weight	EAN	Piece/package
HL6600.2		1700 g	+047628	1

HL6800 Sound insulation pad for HL531

Data

Material	Rubber, based on recycled rubber and PU-elastomer
Dimensions	1200 x 185 x 4/8 mm
Fits for	HL531Prblue Primus drain



HL-Nr.	Dimension	Weight	EAN	Piece/package
6800	1200 x 185 x 4/8 mm	-	+044672	1

Barriere-free shower systems of HL - with sound protection

Peace and quiet within one's own four walls is a basic need and has a significant impact on our health and quality of life. People who are exposed to constant noise suffer from health problems, according to the World Health Organization (WHO). In addition to an increased risk of heart attack, long-term damage caused by constant exposure to noise include sleep disturbances, depression and hearing damage. Whether a noise is perceived as annoying or not essentially depends on the subjective perception of each individual.

What does the standard say about sound insulation?

The ÖNORM B8115:2021 „Sound insulation and room acoustics in building construction“ is to be applied for the standard-compliant planning of sound insulation, in particular noise from building services (which also includes the barrier-free shower). The prerequisite for the application of this standard is the definition of

the use of individual rooms and their quietness expectation or the sound insulation target. This means that the level of sound insulation must be agreed with the client in advance. With the help of ÖNORM B8115-2:2021 and its methodology, the sound insulation level of the used units is determined. On this basis, the classification of sound insulation for building services can be carried out in accordance with ÖNORM B8115-5:2021 Section 5.8 Table 4. Here, a distinction is made between four sound insulation classes from A (high protection) to sound insulation class E (low sound insulation) and thus the sound insulation quality of a building can be declared. In contrast to the predecessor standard, the current edition of the standard omits the „general requirements for sound insulation“.

HL soundproof shower solutions at the highest level!

All barrier-free shower solutions listed in the

table have been tested by the renowned Fraunhofer Institute and can be assigned to the (strictest) highest sound insulation class A according to ÖNORM B8115 2:2021 can be assigned. The highest level of safety is thus guaranteed.

Do you need more details about sound insulation or are you looking for the soundproofing reports for the shower solutions then visit www.hl.at, www.siphoniker.at or contact our service hotline
Tel.: +432235 8629144 or write us an email: support@hl.

Measured value according to ÖNorm B 8115-2

		Measured value according to ÖNorm B 8115-2
Shower channel HL50 serie		17 dB(A)
Shower channel HL53		12 dB(A)
Shower drains/floor drains HL5100, HL90, HL510		< 10 dB(A)
Shower drain/floor drain HL540[I] HL541[I]		12 dB(A), [11] dB(A) <10 dB(A), [<10 dB(A)]
Shower tray drain HL570 Flexbox		12 dB(A)

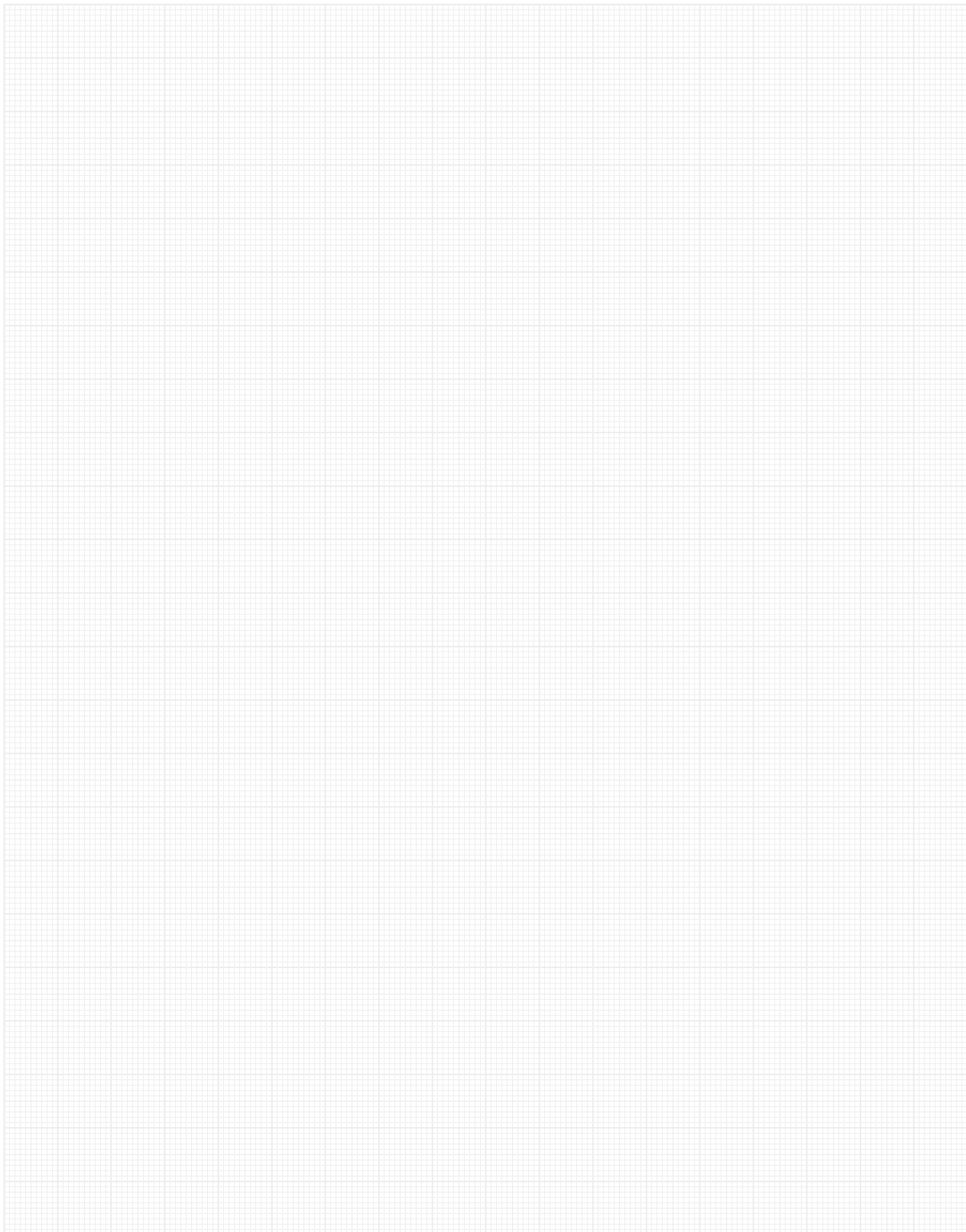



SIPHONS ABLÄUFE

